

Enhancing Transparency and Trust in Agrifood Supply Chains through Novel Blockchain-based Architecture

Sakthivel V^{1*}, Prakash P², Jae-Woo Lee³, and Prabu P⁴

¹School of Computer Science and Engineering
Vellore Institute of Technology, Chennai, India
[e-mail: mvsakthi@gmail.com]

²School of Computer Science and Engineering
Vellore Institute of Technology, Chennai, India
[e-mail: prakash.p@vit.ac.in]

³Konkuk Aerospace Design-Airworthiness Institute,
Konkuk University, Seoul, South Korea
[e-mail: jwlee@konkuk.ac.kr]

⁴Department of Computer Science,
CHRIST (Deemed to be University), Bengaluru
[e-mail: prabu.p@christuniversity.in]

*Corresponding author: Sakthivel V

*Received October 6, 2023; revised December 20, 2023; accepted June 17, 2024;
published July 31, 2024*

Abstract

At present, the world is witnessing a rapid change in all the fields of human civilization business interests and goals of all the sectors are changing very fast. Global changes are taking place quickly in all fields – manufacturing, service, agriculture, and external sectors. There are plenty of hurdles in the emerging technologies in agriculture in the modern days. While adopting such technologies as transparency and trust issues among stakeholders, there arises a pressurized necessity on food suppliers because it has to create sustainable systems not only addressing demand–supply disparities but also ensuring food authenticity. Recent studies have attempted to explore the potential of technologies like blockchain and practices for smart and sustainable agriculture. Besides, this well-researched work investigates how a scientific cum technological blockchain architecture addresses supply chain challenges in Precision Agriculture to take up challenges related to transparency traceability, and security. A robust registration phase, efficient authentication mechanisms, and optimized data management strategies are the key components of the proposed architecture. Through secured key exchange mechanisms and encryption techniques, client's identities are verified with inevitable complexity. The confluence of IoT and blockchain technologies that set up modern farms amplify control within supply chain networks. The practical manifestation of the researchers' novel blockchain architecture that has been executed on the Hyperledger network, exposes a clear validation using corroboration of concept. Through exhaustive experimental analyses that encompass, transaction confirmation time and scalability metrics, the proposed architecture not only demonstrates efficiency but also underscores its usability to meet the

demands of contemporary Precision Agriculture systems. However, the scholarly paper based upon a comprehensive overview resolves a solution as a fruitful and impactful contribution to blockchain applications in agriculture supply chains.

Keywords: Blockchain, Internet of Things, Security, Monitoring, Big data.

1. Introduction

Precision Agriculture [1–3] has gained enormous popularity and attained the necessity of much productivity due to the involvement of high-technology sensor and analysis tools that enable management decisions that bring about an improvement in crop yields. Through the use of a wireless sensor network [4–8] or the deployment of sensors, a large amount of data is collected. The collected are processed and the information gathered would be useful in improving all aspects of agriculture such as the use of resources, yields, and crop quality [9]. To put it differently, precision agriculture involves not only predicting but also anticipating aspects such as soil management, crop maturity rotation, ideal planting schedules, and harvest timings, among other factors. To facilitate the above benefits to the farming system, several enabling technologies (IoT applications, AI technologies, blockchain, remote sensing, etc.) are being used. The combination of IoT with sensor technology has huge capabilities in mitigating several challenges in precision agriculture [10–12]. A sensor system facilitates surveillance services for optimal crop growth and anticipates various crop diseases. Besides machine learning and deep learning technologies are a boon for precision agriculture. Several predictive and detective systems can be built to notice crop diseases [13–16], identify weeds and pests, predict crop harvesting time, etc.

Recently, blockchain technology with the power of IoT applications has emerged as a significant tool for addressing several challenges, particularly in precision agriculture. As per a recent market intellect report from BIS Research, the adoptions of blockchain in precision farming and food supply sequence are expected to surge 41.9 million USD in 2018 to reach 1.4 billion USD by 2028 [29]. Recognizing the limitations of traditional frameworks in ensuring secure, transparent, and energy-efficient transactions, the proposed blockchain architecture emerges as a crucial response to this imperative need. As Precision Agriculture increasingly becomes a linchpin of modern farming practices, the demand for innovative solutions intensifies day by day. This serves to emphasize the intrinsic need for the proposed model—a model strategically designed not only to mitigate the existing supply chain challenges but to reshape the very fabric of how agricultural data is managed, authenticated, and safeguarded. Through a lens that magnifies the complexities of contemporary Precision Agriculture systems, the proposed model not only addresses these challenges but also propels the industry into a new era of efficiency, security, and unparalleled control within the supply chain networks.

Since blockchain has the potential to bring numerous advantages it contributes to various precision agriculture applications. Examples: Smart farming, monitoring and tracking supply chains, managing finances, and ensuring data security and integrity. The increasing usage of public blockchain in food production awakens governments to reevaluate and update their legal frameworks and regulations, integrating blockchain into their economic policies [28]. In the realm of precision agriculture, an essential requirement for blockchain becomes imperative to address the gap between demand and supply while achieving sustainability within the ecosystem. The study's contribution lies in:

- To enhance transparency within the Precision Agriculture supply chain, blockchain technology was used. The blockchain architecture ensures an immutable and transparent ledger, approving a comprehensive view of transactions, certifications, and data movement from farm to market.
- By integrating smart contracts into the blockchain, enabling automated and self-executing transactions, this feature streamlines processes such as financial transactions, crop certification, and insurance, which reduces the need for intermediaries and enhances the overall efficiency of Precision Agriculture operations.
- To address concerns related to data privacy, the study brings into glimpse if implementing the privacy-preserving mechanisms in the blockchain. This ensures that while traceability is maintained for food safety and certification, sensitive information is safeguarded through cryptographic techniques, after striking a balance between transparency and privacy.
- The integration of IoT with blockchain establishes an Internet of Smart Farms, where IoT devices communicate securely through the blockchain, adding a layer of control and efficiency to the entire Precision Agriculture supply chain network.

Multiple ways of blockchain prove beneficial in smart agriculture: Every data transaction, such as updates on crop status or environmental conditions, gets logged in a decentralized and unchangeable ledger. This transparency maintains a dependable record of farm activities which will build trust among stakeholders. Within smart agriculture, IoT offers diverse applications like soil and plant monitoring, crop growth observation, and assistance in irrigation evaluation, along with monitoring agricultural environments. In contract farming, blockchain connects farmers with landowners and supply companies via smart contracts, avoiding the loans of farmers. This facilitates land leasing, seed acquisition, and fertilizer procurement with minimal capital investment. Moreover, blockchain enhances smart livestock farming by enhancing economic viability, operational efficiency, and ecological sustainability. It facilitates the integration of farmers with the biological and environmental data of their livestock, while also improving customer and product identification in the farming supply chain. Additionally, blockchain ensures device security and facilitates consistent data exchange in IoT-enabled smart farming systems.

The study throws light upon a blockchain suitable for Precision Agriculture, enhancing supply chain transparency, automating transactions, and ensuring data privacy. This innovative approach not only revolutionizes agricultural operations scientifically but also sets a precedent for sustainable, efficient, and secure practices technologically in the evolving landscape of smart farming.

1.1 Problem Statement

Unnecessarily Complex Supply chains: The term ‘supply chain’ describes a chain of entities involved in the trade and manufacturing of goods. The architecture of a supply chain is that one entity produces a raw material and sends it to a facility that processes the input to purify it and then, it forwards it for the conversion of the final product. However, from the practical point of you, many more steps may be taken in between, as many raw materials are required for manufacturing.

In reality, the supply chain structure of the modern industry has become as complex as its product itself. Global trade has not only allowed the trading of final products but also of raw materials across the seas. Global trade has allowed a company to have a base in India, a headquarters in London, a manufacturing unit in China, and raw material providers in Africa. Despite being a firm spread like this has its benefits, it brings unnecessary complexity to its supply chain. While in its current nascent phase, research integrating blockchain technology into precision agriculture has outlined five primary use cases, as depicted in Fig. 1. The [19] work prioritizes a comprehensive food traceability system for global food safety. It is designed to monitor the entire food production lifecycle and ensure transparency among all stakeholders in smart agriculture. While the proposed work centers on the specific challenges in addition to the benefits of implementing blockchain in Precision Agriculture for enhanced supply chain control and efficiency. It extends beyond food safety to encompass financial transactions, crop certifications, and insurance processes, marking a targeted approach to meet the demands of contemporary Precision Agriculture systems in the Age of Globalization.

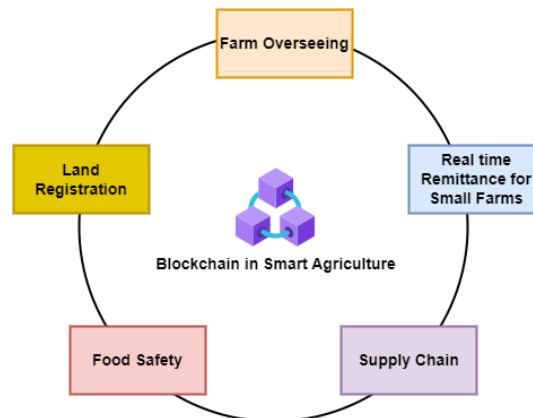

Fig. 1. Blockchain Model

A supply chain in a scenario results unfortunately in enormous inefficiency in logistics, ultimately incurring unwanted charges to the Firm, superfluous fuel, and energy consumption. In the 20th Century Industrial Environment, a few companies handle the entire supply chain while most govern essential parts. Though this practice stands practically beneficial for the Firm, it creates complications in other parts of the chain. For example, Apple. inc designs their product in California; sources their raw materials from 43 different countries worldwide; manufactures essential components like RAM, Display, and Speake in different countries; assembles in China, and gets stored in warehouses in Australia, Japan, Czech Republic, UK, and China. Given this, we suggest a lightweight blockchain architecture in support of smart contracts to address this issue in the paper.

The need for a lightweight blockchain arises from the growing demand for efficient and scalable decentralized applications across various industries. Traditional blockchain networks, such as Bitcoin and Ethereum, often face challenges related to scalability, high resource requirements, and slow transaction speeds. In response to these limitations, a lightweight blockchain provides a well-streamlined and resource-efficient alternative. This is crucial for applications in fields like the IoT, where devices with limited processing power and energy resources need to participate in the blockchain network. Lightweight blockchains aim and attempt to strike a balance between maintaining decentralization and security while optimizing performance, turning them well-suited for applications requiring a nimble and resource-friendly distributed ledger.

The challenges in the adoption and limited uptake of emerging technologies within the agricultural domain include the lack of transparency and trust among involved parties [30]. The flow of products and services occurs typically and unidirectionally, while financial transactions move in the opposite direction. Information, considered a valuable asset, flows bi-directionally within agrifood supply chains [31]. Nonetheless, the inherent imbalance of information and potential misinformation in supply chain transactions remains an ongoing hurdle. In this connection, consumers demand abundant knowledge about the origins of their food, to seek verification for sustainability and a system to access product information [32].

Consequently, food suppliers face immense pressure to establish sustainable systems that reconcile the disparities between agrifood product demand and supply, ensure food provenance, and eliminate centralized authority. State-of-the-art studies underscore the potential of technologies like blockchain, combined with sustainable practices, to enable intelligent and sustainable agriculture. These studies emphasize the necessity of establishing a dependable and trustworthy environment among intermediaries across the agri-food supply chain to achieve sustainability goals. Despite this, there exists a dearth of research focusing on the adoption of blockchain technology [32] for smart and sustainable agriculture.

The proposed model addresses challenges in adopting emerging agricultural technologies, including transparency issues. Traditional product flows are unidirectional, whereas modern agrifood supply chains require bidirectional information flow. Consumers demand transparency in food origins and sustainability verification only. Food suppliers face pressure to establish sustainable systems and eliminate centralized authority. The model integrates blockchain with sustainable practices to bring up intelligent agriculture. Apart from the potential, there's meager research on blockchain adoption in agriculture. The proposed model aims to bridge this gap and provide a comprehensive solution for the industry.

The remaining content is structured as follows: Section 2 delivers a review of the literature, Section 3 outlines the methodology employed in the proposed work, Section 4 details the experiments conducted, and Section 5 presents the conclusions drawn from the earlier contributions and research.

2. Related Research

The power of blockchain alongside the reach through IoT applications remains an ideal combination to improve the agriculture sector. This includes crop harvesting to supply the harvested crop to the end-users. Blockchain technologies have been applied in all the phases of precision farming [17–27]. The integration of the existing logistic supply model with the digital strategy was outlined by the authors in [25]. This approach establishes a universal method for formulating scenarios for the use of Blockchain technology beyond financial applications. The outcomes of a specific use case in food distribution are presented,

highlighting key considerations in the execution of a Blockchain. Following this, the authors have emulated a blockchain model implementation on fresh food delivery service, showing results that emphasize critical aspects of Blockchain implementation. Ultimately, the authors discuss the benefits brought by Blockchain technology in decreasing logistics costs and improving the in-transit actions between source and delivery locations and the research dares.

The authors in [27] explained how introducing Blockchain in Hyperconnected Logistics will undoubtedly improve its mode of operation, and architecture and optimize the performance of logistic services in the globe. They described a model incorporating Blockchain through Smart Contracts for transactions and IOT devices for data collection. They prepared a simulation model to test the performance of their implementation. Results show that though the model's performance is good, it is limited by the speed of transactions on the Blockchain. They proposed that a different Blockchain implementation that uses a faster consensus mechanism will give true benchmarks.

Several research challenges and opportunities related to the incorporation of blockchain and IoT into precision agriculture are described in [28]. The authors have introduced a few innovative blockchain models that offer valuable solutions to significant issues in precision agricultural systems based on the IoT. Moreover, the study investigated and clarified the key features and advantages of commonly employed blockchain for handling numerous aspects of precision farming, such as crop cultivation, livestock grazing, and the food supply sequence.

Similarly, the paper [17] centers on forecasting agricultural events and keeps a secured log of node transactions. The system suggested by the authors in [21] features a blockchain which is said to be its foundational element. Concurrently, IoT devices gather data at the field level, while smart contracts oversee exchanges among the involved entities. In a related context, the authors in [19] present a proposal for a reliable, self-organized, open, and ecologically friendly nutrition traceability system leveraging blockchain. This involves all the phases of precision agriculture that may not be directly connected, i.e., from different parties. An integrated system was discussed in [20]. The research focuses on developing an effective and decentralized routing system to strengthen communication efficiency.

The suggested protocol leverages smart contracts in diverse IoT systems to establish a path to the Base Station. Every node can secure a path beginning with an IoT device to the sink, and then to the base station, enabling collaboration among IoT devices throughout broadcast. The proposed routing protocol eliminates unnecessary data, safeguards against IoT design attacks, and results in reduced energy consumption, to improve the networks. All the aforementioned schemes implement several aspects of precision agriculture using blockchain, including supply chain management. However, a proper lightweight blockchain architecture that involves food safety to pricing is ignored in the supply chain. In this study, we propose excellent and enabling architecture along with related smart contracts for smart precision agriculture applications.

3. Suggested Design

In the study, the proposed model suggests a system that enables smart devices to communicate with every facilitating proper and secured data flow. In the analyzed network, IoT devices will oversee the excellence and status of products stored within expansive warehouses. These devices are entrusted to monitor, collect, and transmit the sensed data to the system. These devices will also be used in the supply chain to act as clients and take the role of different service providers. They can also be used to predict crop prices and crop harvesting. Blockchain technologies will be used to securely store the captured data, i.e., the data transmitted by

various IoT devices. Smart contracts are set to be employed for the automated management of diverse transactions within the system. They will trigger events. To ensure the necessary fulfillment of terms and conditions for all parties involved. **Fig. 2** shows the model considered as the best in this work. To simplify the supply chain through optimal smart contracts in the system model is there are shown aim of the author.

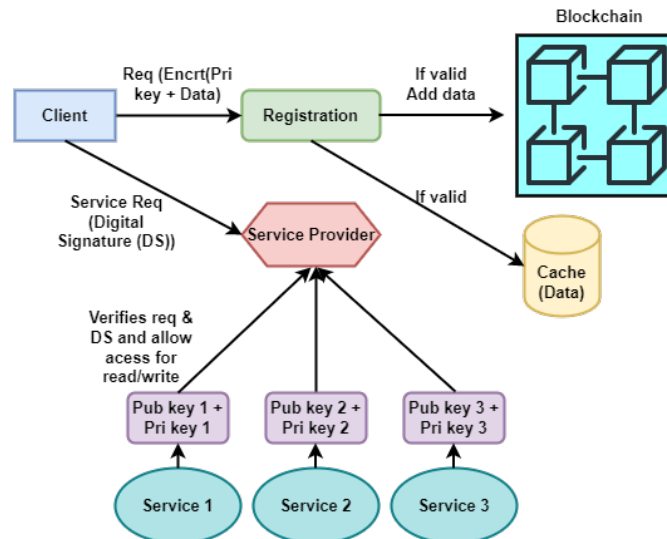

Fig. 2. System Model

We have a registration phase, during which the clients register to the blockchain system. The registration phase within the proposed framework plays a critical role in ensuring the integrity in addition to credibility of participants involved in the blockchain-based architecture for Precision Agriculture. This phase entails several crucial steps. During registration, all users, who are none other than farmers, landowners, and other stakeholders, are required to provide comprehensive information about themselves, encompassing identity verification, contact details, and relevant certifications. Secure key exchange mechanisms are employed during registration to establish cryptographic keys, ensuring the confidentiality and integrity of data transmission within the system. The registration server conducts thorough verification of the client's information and credentials without disclosing personal details, employing identity verification protocols to prevent fraudulent registrations.

User-submitted information is encrypted with a private key to safeguard privacy during registration. Upon successful validation, the registration server records a transaction on the blockchain, signifying the client's registration within the system, which includes pertinent metadata such as client ID, timestamp, and verification status. Subsequently, the registration server issues an acknowledgment (ACK) message to the client, confirming their registration status. This ACK serves as a confirmation receipt and ensures the client is aware of their registration completion. Following this, the registration server optimizes data management by eliminating unnecessary information while maintaining a concise record of registered clients to enhance system efficiency. These processes are elaborately depicted in **Fig. 5**.

Next, the registered clients try to communicate with the nodes that act as service providers to avail of any necessary services. Service providers similarly register themselves in the blockchain. To authenticate this communication between any two nodes, the clients send a message containing information gathered during the registration phase. The client's private key is used to encrypt the session and request information. It is then validated by the

registration server and the service provider stores a copy locally in its cache. The service provider designates a transaction as valid when it is successfully added. Conversely, marks it as invalid if it is not added. It removes it from the local cache. The authentication process achieves completion upon the service provider receiving an ACK message from the client.

Following this, the service provider records an access transaction log in the blockchain system. Moreover, service providers uphold a public-private key pair for each service they provide, such as logistics, warehouse, and cold storage. As part of this setup, when clients gain access to a specific service, they receive the corresponding public key for that particular service. It ensures differentiation between different services and provides authentication and authorization of the client node in accessing a service. This is achieved by sending a service request along with the digital signature of that particular requested service. The client's private key will be used to encrypt this request message.

The service provider verifies that the service request receives a digital signature and provides access to read/write if the provided details are correct. The communication is terminated from the service provider following the ACK that is to be received from the client side. After verification of the digital signatures, the node acting as the service provider is entrusted with the responsibility of adding the transaction as authorization permission of the client to the blockchain. Then this node starts mining the transaction as shown in [Fig. 7](#). For key exchanges in the aforementioned steps, researchers use the cryptography algorithms available in the literature.

At the production stage, IoT devices gather data on soil conditions, weather patterns, and crop growth, securely recorded on the blockchain one by one. This immutable record allows farmers to track and verify the origin and quality of their produce, ensuring compliance with agricultural standards. IoT sensors in packaging monitor environmental conditions, triggering alerts for deviations to prevent quality degradation. Consumers can access comprehensive product information by scanning QR codes or using mobile apps, viewing details on origin, cultivation practices, and storage conditions. This transparency builds consumer trust in the food supply chain. In the event of a food safety issue, the blockchain-enabled system facilitates rapid identification of affected products, minimizing public health risks and economic losses. Additionally, the model incorporates advanced traceability techniques like barcodes, QR codes, biotracing, nanosensors, GPS, and GIS. These techniques further enhance product tracking accuracy, ensuring proactive measures for quality and safety maintenance. By combining blockchain, IoT, and advanced traceability techniques, the proposed model establishes a comprehensive traceability system, enhancing food safety and consumer confidence.

For enforcing access control, the following steps are taken, namely,

a) Encryption: wherein each miner will generate its public and private key pairs. Any miner will add a transaction to the blockchain through public key signatures to ensure confidentiality. All the miners' public keys are maintained by the system and this assists during communication among service providers.

b) Digital signature: each of the miners has to digitally sign a transaction. This ensures integrity as well as tamper-proof the messages.

c) Verification: This is done by verifying the digitally signed messages. The message is then decrypted. Consensus protocol is used to validate a transaction that is to be added to the blockchain. In this paper, a private network for the miners is perfectly handled.

The proposed system facilitates seamless communication among smart devices, ensuring smooth and secure data transfer while this efficient communication minimizes unnecessary

overhead. It guarantees the effective transmission of data between IoT devices and the blockchain system. This enhanced efficiency also allows farmers to directly market their produce to either or retailers, sidestepping conventional intermediaries and cutting costs. Blockchain technology securely preserves data collected from IoT devices. By discarding redundant data once successfully integrated into the blockchain, the system diminishes storage demands and eases the overall burden, resulting in a streamlined architecture.

During the registration phase, the system employs efficient authentication methods. Through key exchanges and encryption techniques, client identities are verified without undue complexity, by dint of reducing computational load and ensuring lightweight operation. By distributing authentication responsibilities among service providers and clients, the system diminishes central authority and promotes streamlined operation. Taking into account the aforementioned factors, the proposed blockchain-based agriculture system has emerged as a lightweight model with practical achievement.

3.1 Smart Contract Concept

In the envisioned system model, IoT sensor devices detect and collect data from the nearby agricultural field throughout the supply chain logistics process. The data captured enters the blockchain for validation by the system. Fig. 3 illustrates the storage of two types of transaction data in the blockchain system. Firstly, data originating from traditional ERP legacy systems, such as trade, logistics, delivery, and warehousing information, are recorded. Secondly, data generated from IoT devices, including air temperature, humidity, soil pH, nutrition levels, and ground moisture, are also stored. Following hashing and digital signing, these datasets are transmitted to all nodes of the blockchain system directly or via IoT gateways. Upon reception, they undergo verification. They are added to the transaction pool. They are stored in the blockchain.

Customers can access and verify transaction data using computers or mobile devices. For instance, when purchasing a kilogram of tomatoes from a supermarket, a consumer can scan the 2-D barcode with a smartphone to retrieve comprehensive transaction details. These details encompass the origin farm, production date and time, farm and staff IDs, collection device information, packaging details, and all environmental data throughout the tomato's lifecycle from production to logistics and storage. However, blockchain validation ensures the authenticity of this information perfectly well.

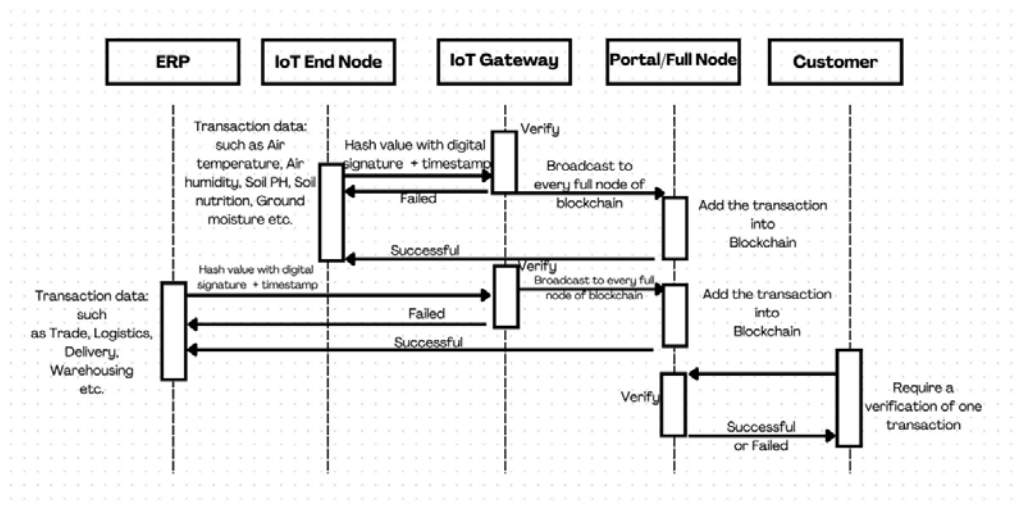

Fig. 3. Flowchart for Smart Contracts

About future work, this system can be, in a better way, improvised through AI/ML tools. Smart contracts are built to set prior permissions and secure the transactions from the source to the final unit of the supply chain. Transaction includes multiple layers while writing and validating data. Firstly, the data is to be added to the ledger from a trusted source. Let it be done at each phase of the supply chain. Secondly, the transaction details have to be in proper format. This ensures that data is not ignored due to wrong formatting. Finally, it is to be ascertained whether all the protocols follow the smart functions at the data layer.

In the proposed smart contracts, several types of transactions are securely verified. For instance, in one smart contract, the transnational data in the supply chain would be TradeId, Delivery info, WarehouseID, etc, which would be hashed with digital signature and timestamp information. This information would be broadcast to all the nodes of the blockchain. All nodes will confirm this transaction as a success or failure.

4. Experiments

In this study, the following figures provide a blockchain-based environment for the implementation and testing of blockchain mechanisms put forth. In this paper. Implementing the proposed architecture is the focus. The implementation results are given in the following subsection. A few of the implementation snapshots are shown in [Fig. 4](#), [Fig. 5](#), [Fig. 6](#), [Fig. 7](#), [Fig. 8](#), and [Fig. 9](#).



Fig. 4. Food Network Blockchain

Consumer Registration

Full Name:

User Name:

Password:

Profession :

Place:

Mobile :

Farmer

Processor

Distributor

Retailer

Consumer

Fig. 5. Consumer Registration

VIEW STATUS

Product name	Quantity	Price	Retailer	Hash Key
paddy	500	1680.0	retail	a85296e88a89b37cd47138caa8a0782e

Buy Product

View status

Logout

Fig. 6. The view status represents product status with quantity, price, retailer, and hash key

Farmer Page



Add Crop

View status

Logout

Fig. 7. Farmer page. It contains the details of adding a crop and viewing the status of the crop.



Fig. 8. Processor page. It contains the options of buying crops and viewing the status

VIEW STATUS				
Crop name	Quantity	Price	Processor	Hash Key
paddy	500	1200	process1	a771e01d1b5fe42625b9a9f1dc515921
Crop name	Quantity	Price	Processor	Hash Key
sugarcane	2300	100	process1	5515859f13eccbdc590b234575c33e32

Add Crop
View status
Logout

Fig. 9. Hash Status Former.

4.1 Transaction Management

At the initial stage, our system has been tested for robustness and managing several clients (nodes) in the proposed blockchain model and then, the developed smart contracts are tested. Let several IoT devices (incrementally) be allowed to connect and measure the enactment of the scheme. In the considered scenario, the proposed blockchain network permits all the requests from the client devices (concurrently) to access the resources. This experiment was performed 50 times and an average is computed. It can be observed that the system is highly robust and handles several concurrent client requests without affecting the successful request for resources. This could be termed as the throughput of the system. The designed smart contracts can handle up to 1000 clients as tested for this system. The transaction period needs more or less a few seconds. However, in the proposed scheme this does not significantly impact the communication between a client and a service provider.

4.2 Client Authentication

To validate a client's authentication, the service provider interacts with the developed blockchain after receiving the registration transaction. In the case of no record being found against a service request, an invalid message is communicated. Only successful registered

entities perform transactions. It's important to highlight that the registration server is prohibited from executing a read operation on the blockchain to prevent potential privacy concerns.

5. Results

The results depicted in **Fig. 10** provide valuable insights into the performance of the proposed model, particularly regarding transaction processing times. The distribution of processing times showcases the efficiency and reliability of the system in handling transactions within an acceptable timeframe. The average processing time of 15s indicates that the proposed model is capable of efficiently processing transactions, thereby ensuring the timely execution of operations within the network. While there were instances where a few transactions took longer than one minute to process, such occurrences were minimal, underscoring the overall effectiveness of the system in maintaining acceptable processing times. By achieving acceptable processing times and minimizing delays, the model enhances the overall efficiency and reliability of the network, making it a promising solution for the agricultural domain.

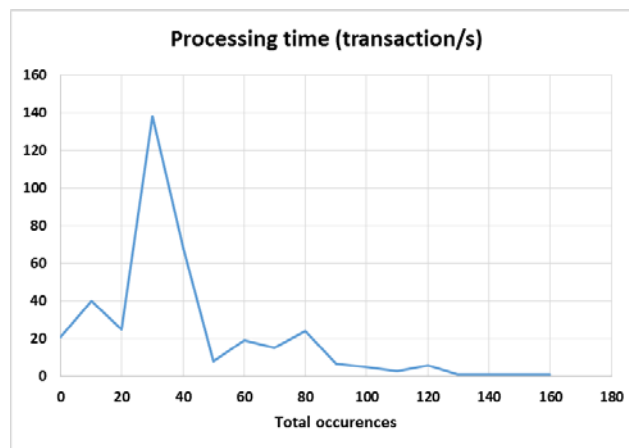

Fig. 10. Transaction Processing Time

Fig. 11 observed an increase in throughput as the number of nodes in the proposed model increases underscoring the scalability and robustness of the blockchain-based precision agriculture system. This phenomenon is particularly notable in the context of agricultural supply chains, where multiple stakeholders and entities are involved in the production, distribution, and sale of food products. The distributed nature of blockchain technology ensures that transaction processing is not reliant on a single centralized entity. As the number of nodes increases, the network becomes more decentralized, enabling parallel processing of transactions across multiple nodes. This decentralized architecture enhances the overall throughput of the system, allowing for greater scalability and resilience against single points of failure.

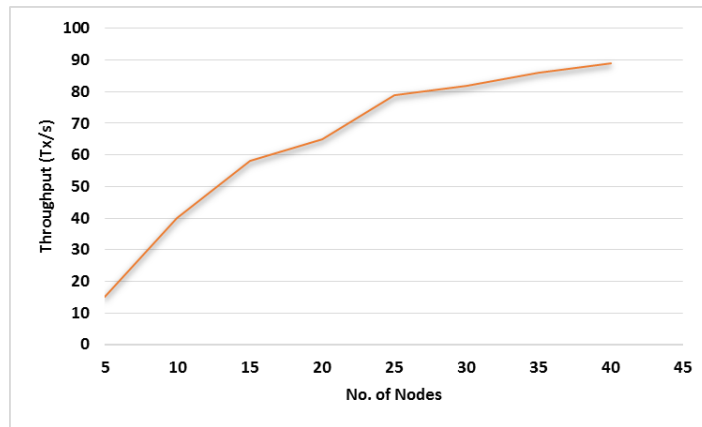

Fig. 11. Throughput value of blockchain-based precision agriculture

The comparison of **Fig. 12** of the proposed and existing [33] models based on the block size parameter reveals the superiority of the proposed model. One key reason for the proposed model's superiority lies in its optimization of data management processes. The registration server within the proposed framework efficiently manages data by eliminating unnecessary information, resulting in a concise record of registered clients. This optimization enhances system efficiency by reducing storage requirements and minimizing computational overhead.

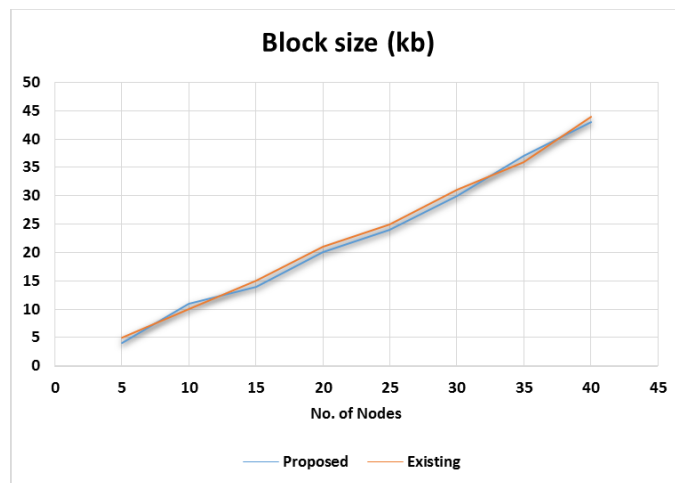

Fig. 12. Block Size Comparison

By maintaining a streamlined record of registered clients, the proposed model effectively mitigates the impact of increasing node numbers on system performance. As evidenced by **Fig. 12**, even as the number of nodes escalates, the proposed model consistently exhibits lower block sizes compared to the existing model. This indicates that the proposed model manages data processing and storage, resulting in smaller block sizes across varying network configurations as expected.

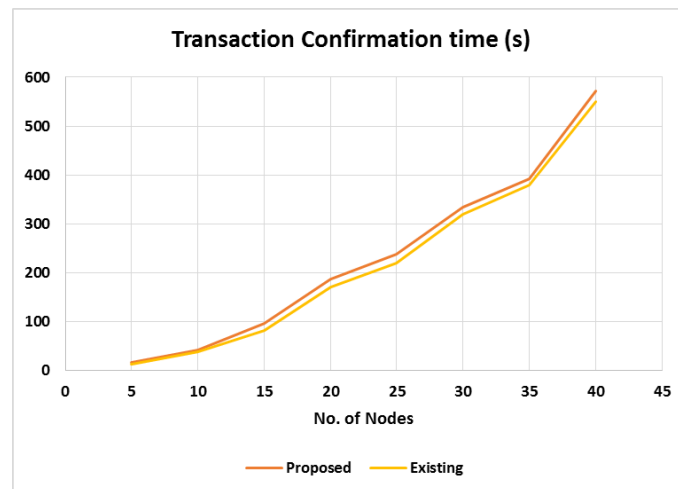

Fig. 13. Confirmation Time Comparison

The comparison of transaction confirmation times between the proposed and existing [33] models, as shown in Fig. 13, demonstrates that the proposed model generally exhibits longer confirmation times compared to the existing model as the number of nodes increases. One key reason for the longer transaction confirmation times in the proposed model is its emphasis on greater security. Longer confirmation times typically imply that transactions have been validated by a larger number of blocks, which enhances security against double-spending attacks.

In the context of precision agriculture food supply chains, where transactions involve high-value assets and sensitive data, prioritizing security over speed is paramount. Therefore, the longer confirmation times observed in the proposed model signify a higher level of security and trustworthiness, making it suitable for applications that require robust protection against fraudulent activities. Moreover, the architecture of the proposed model, particularly its authentication and authorization mechanisms, contributes to the longer transaction confirmation times. The process of authenticating communication between nodes, involving encryption, validation, and acknowledgment, adds a layer of security and an advisable utility.

6. Conclusion

In the study, a blockchain-founded design for precision agriculture is presented. The architecture simplifies the supply-chain management. It adds several functionalities. It facilitates an optimal system from farming to delivery of the farm products to the customers. It provides secured record keeping and verification. However, it avoids fraud and trust enhancement in the electronic agro-market. The proposed blockchain is capable of managing a massive scale of data from the supply chain phase. As part of future work, traceability can be integrated into the system, although the potential compromise of privacy is to be carefully addressed in the design architecture for comprehensive development. Additionally, exploring innovative consensus mechanisms and scalability solutions will be crucial for adapting the blockchain to meet the demands of agriculture. Moreover, as a part of future work, this system can be further improvised through the incorporation of advanced AI/ML tools, in such a way that it enables strong decision-making and predictive analytics for optimized agricultural processes.

Acknowledgment

The authors express gratitude for the contributions of the editors and reviewers. This study has not received funding from public, commercial, or not-for-profit entities the predominant information that is available from the study sources is much conducive to a significant increase in processing effort for future research.

References

- [1] H. Yin, Y. Cao, B. Marelli, X. Zeng, A. J. Mason, and C. Cao, "Smart agriculture systems: Soil sensors and plant wearables for smart and precision agriculture," *Advanced Materials*, vol.33, no.20, May. 2021. [Article \(CrossRef Link\)](#)
- [2] F. J. Pierce and P. Nowak, "Aspects of Precision Agriculture," *Advances in Agronomy*, vol.67, pp.1-85, 1999. [Article \(CrossRef Link\)](#)
- [3] N. Zhang, M. Wang, and N. Wang, "Precision agriculture—a worldwide overview," *Computers and Electronics in Agriculture*, vol.36, no.2-3, pp.113-132, Nov. 2002. [Article \(CrossRef Link\)](#)
- [4] N. Choudhury, R. Matam, M. Mukherjee and J. Lloret, "LBS: A Beacon Synchronization Scheme With Higher Schedulability for IEEE 802.15.4 Cluster-Tree-Based IoT Applications," *IEEE Internet of Things Journal*, vol.6, no.5, pp.8883-8896, Oct. 2019. [Article \(CrossRef Link\)](#)
- [5] R. Akhter and S. A. Sofi, "Precision agriculture using IoT data analytics and machine learning," *Journal of King Saud University - Computer and Information Sciences*, vol.34, no.8, pp. 5602-5618, 2022. [Article \(CrossRef Link\)](#)
- [6] N. Choudhury, R. Matam, M. Mukherjee, and L. Shu, "Distributed Beacon Synchronization Mechanism for 802.15.4 Cluster-Tree Topology," in *Proc. of Wireless Internet. WICON 2016*, pp.10-20, 2018. [Article \(CrossRef Link\)](#)
- [7] A. Hazarika, S. Poddar, M. M. Nasralla, and H. Rahaman, "Area and energy efficient shift and accumulator unit for object detection in IoT applications," *Alexandria Engineering Journal*, vol.61, no.1, pp.795-809, 2022. [Article \(CrossRef Link\)](#)
- [8] N. Choudhury and R. Matam, "Distributed beacon scheduling for IEEE 802.15.4 cluster-tree topology," in *Proc. of 2016 IEEE Annual India Conference (INDICON)*, 2016. [Article \(CrossRef Link\)](#)
- [9] N. Choudhury and A. Hazarika, "Low-Power DSME-Based Communication and On-Board Processing in UAV for Smart Agriculture," in *Proc. of Information and Communication Technology for Competitive Strategies (ICTCS 2020)*, pp.639-648, 2021. [Article \(CrossRef Link\)](#)
- [10] N. Ahmed, D. De, and I. Hussain, "Internet of Things (IoT) for Smart Precision Agriculture and Farming in Rural Areas," *IEEE Internet of Things Journal*, vol.5, no.6, pp.4890-4899, Dec. 2018. [Article \(CrossRef Link\)](#)
- [11] M. A. Khan, M. M. Nasralla, M. M. Umar, Ghani-Ur-Rehman, S. Khan, and N. Choudhury, "An Efficient Multilevel Probabilistic Model for Abnormal Traffic Detection in Wireless Sensor Networks," *Sensors*, vol.22, no.2, Jan. 2022. [Article \(CrossRef Link\)](#)
- [12] A. Hazarika, S. Poddar, and H. Rahaman, "Survey on memory management techniques in heterogeneous computing systems," *IET Computers & Digital Techniques*, vol.14, no.2, pp.47-60, Jan. 2020. [Article \(CrossRef Link\)](#)
- [13] A. Hazarika, P. Sistla, V. Venkatesh, and N. Choudhury, "Approximating CNN Computation for Plant Disease Detection," in *Proc. of 2022 IEEE 46th Annual Computers, Software, and Applications Conference (COMPSAC)*, pp.1117-1122, 2022. [Article \(CrossRef Link\)](#)
- [14] S. Ashwinkumar, S. Rajagopal, V. Manimaran, and B. Jegajothi, "Automated plant leaf disease detection and classification using optimal MobileNet based convolutional neural networks," *Materials Today: Proceedings*, vol.51, pp.480-487, 2022. [Article \(CrossRef Link\)](#)
- [15] S. Sladojevic, M. Arsenovic, A. Anderla, D. Culibrk, and D. Stefanovic, "Deep Neural Networks Based Recognition of Plant Diseases by Leaf Image Classification," *Computational Intelligence and Neuroscience*, 2016. [Article \(CrossRef Link\)](#)

- [16] A. Hazarika, S. Poddar, and H. Rahaman, "High Performance Kernel Architecture for Convolutional Neural Network Acceleration," *Journal of Circuits, Systems and Computers*, vol.30, no.15, 2021. [Article \(CrossRef Link\)](#)
- [17] A. A. Khan, Z. A. Shaikh, L. Belinskaja, L. Baitenova, Y. Vlasova, Z. Gerzelieva, A. A. Laghari, A. A. Abro, and S. Barykin, "A Blockchain and Metaheuristic-Enabled Distributed Architecture for Smart Agricultural Analysis and Ledger Preservation Solution: A Collaborative Approach," *Applied Sciences*, vol.12, no.3, Jan. 2022. [Article \(CrossRef Link\)](#)
- [18] K. Dey and U. Shekhawat, "Blockchain for sustainable e-agriculture: Literature review, architecture for data management, and implications," *Journal of Cleaner Production*, vol.316, 2021. [Article \(CrossRef Link\)](#)
- [19] J. Lin, Z. Shen, A. Zhang, and Y. Chai, "Blockchain and IoT based Food Traceability for Smart Agriculture," in *Proc. of ICCSE'18: Proceedings of the 3rd International Conference on Crowd Science and Engineering*, pp.1-6, 2018. [Article \(CrossRef Link\)](#)
- [20] S. H. Awan, S. Ahmed, A. Nawaz, S. S. Maghdid, K. Zaman, M. Y. Ali Khan, Z. Najam, and S. Imran, "BlockChain with IoT, an Emergent Routing Scheme for Smart Agriculture," *International Journal of Advanced Computer Science and Applications(IJACSA)*, vol.11, no.4, pp.420-429, 2020. [Article \(CrossRef Link\)](#)
- [21] T. H. Pranto, A. A. Noman, A. Mahmud, and A. B. Haque, "Blockchain and smart contract for IoT enabled smart agriculture," *PeerJ Computer Science*, vol.7, 2021. [Article \(CrossRef Link\)](#)
- [22] A. N. Putri, M. Hariadi, and A. D. Wibawa, "Smart Agriculture Using Supply Chain Management Based On Hyperledger Blockchain," in *Proc. of IOP Conference Series: Earth and Environmental Science, International Conference on Climate Smart Sustainable Agriculture*, vol.466, no.1, 2020. [Article \(CrossRef Link\)](#)
- [23] G. Sagirlar, B. Carminati, E. Ferrari, J. D. Sheehan and E. Ragnoli, "Hybrid-IoT: Hybrid Blockchain Architecture for Internet of Things - PoW Sub-Blockchains," in *Proc. of 2018 IEEE International Conference on Internet of Things (iThings) and IEEE Green Computing and Communications (GreenCom) and IEEE Cyber, Physical and Social Computing (CPSCom) and IEEE Smart Data (SmartData)*, pp.1007-1016, 2018. [Article \(CrossRef Link\)](#)
- [24] M. Verma, "Smart contract model for trust based agriculture using blockchain technology," *International Journal of Research and Analytical Reviews*, vol.8, no.2, pp.344-345, 2021. [Article \(CrossRef Link\)](#)
- [25] G. Perboli, S. Musso, and M. Rosano, "Blockchain in Logistics and Supply Chain: A Lean Approach for Designing Real-World Use Cases," *IEEE Access*, vol.6, pp.62018-62028, 2018. [Article \(CrossRef Link\)](#)
- [26] O. Novo, "Blockchain Meets IoT: An Architecture for Scalable Access Management in IoT," *IEEE Internet of Things Journal*, vol.5, no.2, pp.1184-1195, 2018. [Article \(CrossRef Link\)](#)
- [27] Q. Betti, R. Khoury, S. Hallé, and B. Montreuil, "Improving Hyperconnected Logistics With Blockchains and Smart Contracts," *IT Professional*, vol.21, no.4, pp.25-32, 2019. [Article \(CrossRef Link\)](#)
- [28] M. Torky and A. E. Hassanein, "Integrating blockchain and the internet of things in precision agriculture: Analysis, opportunities, and challenges," *Computers and Electronics in Agriculture*, vol.178, 2020. [Article \(CrossRef Link\)](#)
- [29] Klerk, E., The global food system: Identifying sustainable solutions. Credit-suisse.com, 2021. <https://www.credit-suisse.com/media/assets/corporate/docs/about-us/research/publications/the-global-food-system-identifying-sustainable-solutions.pdf>
- [30] S. S. Kamble, A. Gunasekaran, and R. Sharma, "Modeling the blockchain enabled traceability in agriculture supply chain," *International Journal of Information Management*, vol.52, 2020. [Article \(CrossRef Link\)](#)
- [31] G. K. Akella, S. Wibowo, S. Grandhi, and S. Mubarak, "A Systematic Review of Blockchain Technology Adoption Barriers and Enablers for Smart and Sustainable Agriculture," *Big Data Cogn. Comput.*, vol.7, no.2, 2023. [Article \(CrossRef Link\)](#)

- [32] M. Kouhizadeh, S. Saberi, and J. Sarkis, "Blockchain technology and the sustainable supply chain: Theoretically exploring adoption barriers," *International Journal of Production Economics*, vol. 231, 2021. [Article \(CrossRef Link\)](#)
- [33] A. F. Mendi, "Blockchain for Food Tracking," *Electronics*, vol.11, no.16, 2022. [Article \(CrossRef Link\)](#)



Dr. V. Sakthivel is an Assistant Professor Senior Grade at Vellore Institute of Technology, Chennai. He completed his Post Doctorate Fellowship at Konkuk University, Seoul, and holds a Ph.D. in Information and Communication Engineering from Anna University, Chennai. With 14 years of teaching and industry experience, his research focuses on Cloud Computing, Blockchain, Cryptocurrency, and Software Defined Networks. Dr. Sakthivel has presented 65 papers at conferences and published 25 in journals. He is certified in Microsoft Azure, AWS, and RedHat, and is a member of IEEE, ACM, and ISTE.



Prakash Periyaswamy received a Ph.D. in Information and Communication Engineering from Anna University in 2016. He currently serves as an Associate Professor at the Department of Computer Science Engineering, Vellore Institute of Technology, Chennai. His research interests include cloud computing and artificial intelligence. He has presented 40 papers at national and international conferences and has published 25 papers in international journals. He has acted as a reviewer and editorial member for more than 25 international conferences and journals.



Dr. Jae-Woo Lee is a Professor and Director of the Konkuk Aerospace Design-Airworthiness Research Institute at Konkuk University. He holds B.S. and M.S. degrees from Seoul National University and a Ph.D. from Virginia Tech. With over 570 publications, including 13 patents and 74 journal articles, his research focuses on multidisciplinary design optimization and aerospace vehicle design. He has chaired international conferences and served on South Korea's defense and aerospace committees. Dr. Lee is a former President of the Korean Society of Aeronautics and Space Sciences and the Korean Society of Design Optimization.



Dr. P. Prabu, Assistant Professor in the Department of Computer Science at CHRIST (Deemed to be University), Bengaluru, holds an M.C.A. and Ph.D. in computer applications from Anna University, Chennai. With over 16 years of academic and industry experience, his research focuses on ERP, mobile applications, and open-source software. He has published over 50 papers in prestigious journals, boasting an H-index of 16. His interests include software engineering, security, web services, deep learning, IoT, and mobile applications.