

## **RESEARCH ARTICLE**

# Learning motivation of groups classified based on the longitudinal change trajectory of mathematics academic achievement: For South Korean students

Yongseok Kim<sup>1</sup>

<sup>1</sup>Lecturer, Department of mathematics Education, Sungkyunkwan University

Received: January 23, 2024 / Revised: March 2, 2024 / Accepted: March 14, 2024  
© The Korea Society of Mathematics Education 2024

### **Abstract**

This study utilized South Korean elementary and middle school student data to examine the longitudinal change trajectories of learning motivation types according to the longitudinal change trajectories of mathematics academic achievement. Growth mixture modeling, latent growth model, and multiple indicator latent growth model were used to examine various change trajectories for longitudinal data. As a result of the analysis, it was classified into 4 subgroups with similar longitudinal change trajectories of mathematics academic achievement, and the characteristics of the mathematics subject, which emphasize systematicity, appeared. Furthermore, higher mathematics academic achievement was associated with higher self-determination and higher academic motivation. And as the grade level increases, amotivation increases and self-determination decreases. This study suggests that teaching and learning support using this is necessary because the level of learning motivation according to self-determination is different depending on the level of mathematics academic achievement reflecting the characteristics of the student.

**Keywords:** longitudinal data, growth mixture modelling, latent growth model, mathematics academic achievement, learning motivation, self-determination theory

## I. INTRODUCTION

Although having fun while learning increases interest in learning itself, learning is not always a pleasant experience. In some cases, learners may not be very interested in the task, but they rather concentrate on it because of environmental factors, or they may give up on their own, even if it is a task they want to do. Like this, learners must constantly decide whether to continue or stop performing various tasks during the learning process. Factors that trigger or sustain learning behavior have a lot to do with how learners' perceptions lead to task performance (Filgona et al., 2020). *Learning motivation* refers to these psychological attributes and can be defined as the tendency of a learner to choose a goal that is of value to themselves, engage in learning activities, and strive to achieve that goal (Pintrich & Schunk, 2002).

In general, motivation types for learners can be divided into extrinsic and intrinsic motivations based on the location of the factors that induce motivation. The relationship between these two types of motivation has been debated as oppositional (Diseth et al., 2020; Zaccone, & Pedrini, 2019) rather than complementary (Zheng et al., 2022). However, with the advent of the self-determination theory (SDT), instead of considering extrinsic and intrinsic motives as a dichotomy, motives have been placed on a continuum according to the degree of self-determination (Deci & Ryan, 2000).

According to SDT, learners' self-determination can develop even with the intervention from extrinsic motivation. In addition, extrinsic motivation can be classified into various types depending on how learners perceive it (Deci & Ryan, 2000). Even if activities are performed according to the extrinsic motive type, it is believed that behaviours following high self-determination motives can lead to more positive performance than behaviours associated with low self-determination (Guay, 2022). In this respect, extrinsic motivation is not a factor that lowers learners' intrinsic motivation; it can play an auxiliary role in facilitating learners' voluntary motivation formation (Ryan & Deci, 2000). Moreover, extrinsic and intrinsic motivations can be viewed as mutually interacting concepts rather than as opposed to each other (Deci & Ryan, 2000; Ryan & Deci, 2000). SDT holds promising implications for the educational field because it posits that extrinsic motivation can be converted into voluntary and intrinsic motivation through the process of internalisation (Ryan & Deci, 2020). Learners must learn voluntarily by themselves by enhancing their intrinsic motivation during the learning process. However, directly instructing learners to be intrinsically motivated is challenging. Therefore, it is necessary to consider how learners autonomously promote learning by converting extrinsic into intrinsic motivation.

Additionally, as self-determination plays an important role in the satisfaction of individual needs and psychological growth and development, it is known to significantly influence the formation of learners' learning motivation and academic achievement (Deci & Ryan, 2000). As SDT has emerged, research has been conducted by subdividing the types of motivation according to the degree of self-determination. For example, Deci and Ryan (2000) defined levels of self-determination based on the degree to which an individual responds to a given mode of control, and grouped them into six categories (non-regulation, external, introjected, identified, integrated, and intrinsic regulations). Despite

these studies, as most studies examining the effect of learning motivation on academic achievement still do not distinguish motivation by type (Chan et al., 2015; Duke et al., 2021; Tremblay-Wragg et al., 2021), researchers have tended to divide it into extrinsic and intrinsic types (Diseth et al., 2020; Zaccone, & Pedrini, 2019). In addition, although some studies classified learning motivation according to the SDT and analysed the effect on academic achievement (Lee, 2003; Guay, 2022; Ryan & Deci, 2020), research examining individual subjects, such as mathematics, has been insufficient. Moreover, even if the research was related to all subjects, it was mainly cross-sectional, and longitudinal studies are scarce. Academic achievement is a holistic result that reflects students' abilities, attitudes, knowledge, skills, dispositions, and characteristics and is constantly changing under the influence of many factors (Kim, 2020). Just as students' abilities and characteristics vary, longitudinal change trajectories in academic achievement may also vary. However, existing longitudinal studies on academic achievement set all students who were the subjects of research into the same group. Therefore, it was difficult to examine various longitudinal change trajectories according to students' abilities and characteristics (Kim, 2020). Therefore, to support appropriate teaching and learning, in addition to a cross-sectional study conducted at a fixed point in time, a longitudinal study that can reveal the trajectory of changes in academic achievement is needed. In addition, it is necessary to look at various longitudinal trajectories of change in academic achievement, but research on this is very scarce.

This study focused on mathematics because it emphasises systematicity more than other subjects. Accumulated learning from the past can further strengthen learning in current or subsequent grades; therefore, if basic learning about mathematics is not properly acquired in lower grades, it may also affect subsequent mathematics learning, resulting in learning deficits or stagnation (Kim, 2020; Geary, 2011). Therefore, looking at the longitudinal trajectory of change in mathematics academic achievement can be a good opportunity to identify deficits and deficiencies in mathematics learning and support teaching-learning. In this study, examines the longitudinal change trajectories of students' mathematics academic achievement from the 6th grade (elementary school) to the 3rd year of middle school in South Korea, using latent growth model (LGM) and multiple indicator latent growth model (MILGM). In addition, growth mixture modeling (GMM) was implemented to classify groups with similar longitudinal change trajectories in mathematics academic achievement, then compare and analyses the learning motivation of each group.

The research questions of the study are as follows:

1. What is the longitudinal change trajectory of mathematics academic achievement for the whole group?
2. What is the longitudinal change trajectory of motivation type according to the level of self-determination for the whole group?
3. What is the trajectory of longitudinal change in mathematics achievement by group?
4. What is the longitudinal change trajectory of motivation type according to the level of self-determination by group?

## II. RELATED LITERATURE

### **Motivational type according to the degree of self-determination**

Self-determination is possible when the actor perceives that they have the cause and choice of actions, and the will and ability to act (Ryan & Deci, 2017). Self-determination is necessary to satisfy the need for ability, relationships, and autonomy, and for personal psychological growth and development. It is also a necessary factor in recognising the environmental properties that support or hinder it (Deci & Ryan, 1985; Ryan & Deci, 2017). SDT is a theory of motivation for human behaviour based on a growth-oriented view of human beings. It determines the source of motivation for an individual's behaviour, determines the type of motivation, and explains the series of processes in which these motivations are formed (Ryan & Deci, 2017). In general, motivation can be divided into extrinsic and intrinsic types, but SDT describes it as a characteristic that can exist on a continuum depending on the degree of self-determination rather than simply distinguishing between the two types (Ryan & Deci, 2000, 2017).

The motivational type in this study is based on the concept by Deci and Ryan (2000). Deci and Ryan (2000) divided motives into the following six categories according to the regulation degree of self-determination along a single continuum: non-regulation, external, introjected, identified, integrated, and intrinsic regulations. Amotivation is a state in which there is no self-determination, and thus, a lack of will to take action in learning or performing a task (Deci & Ryan, 2000, 2017; Kim & Oh, 2001). In this state, a student does not internalise their learning motivation, doubts the performance of their learning behaviour, and falls into a sense of helplessness that they do not have the confidence to do without making any effort to achieve learning (Kim & Oh, 2001). In other words, amotivated learners do something without any intention of doing it (Ryan & Deci, 2000, 2017).

External regulation is a type of extrinsic motivation that is opposed to intrinsic motivation in early motivation research (Ryan & Deci, 2000, 2017). In the absence of self-determination, it involves doing something to follow rules or to avoid punishment. This can be considered the most extreme form of extrinsic synchronisation (Kim & Oh, 2001).

Introjected regulation is a type of behaviour that seeks to gain approval from oneself and others or to avoid criticism (Ryan & Deci, 2000). In other words, it is a motivational type in which one follows external demands or rules when deciding on behaviour, but the values are not internalised; they are instead injected and control one's behaviour (Kim & Oh, 2001). In addition, behaviour is determined through shame, avoidance of sin, and pressure based on inner self-esteem (Deci & Ryan, 1985; Ryan & Deci, 2017).

Identified regulation is an autonomous motivational type, in which a person decides that an action is worthwhile and voluntarily chooses it because of personal importance or an assigned goal (Ryan & Deci, 2000, 2017). It is classified as extrinsic motivation because one is motivated to achieve a certain purpose rather than through self-satisfaction or pleasure in the achievement of the behaviour itself (Kim & Oh, 2001).

Integrated regulation appears when identified regulation, the most autonomous

type of extrinsic motivation, is fully assimilated with desires, values, and goals accepted as part of itself (Ryan & Deci, 2000, 2017). Integrated regulation is similar to intrinsic motivation because intrinsic regulation is achieved, and behaviour is based on self-determination and autonomy. In addition, it is also identified as a concept indistinguishable from identified or intrinsic regulation (Deci & Ryan, 2008).

Intrinsic regulation is the motivational type with the highest self-determination, and people with this type of motivation act for internal pleasure (Ryan & Deci, 2000, 2017). This type of person engages in the goal activity for enjoyment and interest in the activity itself, without a specific reward (Deci & Ryan, 2000, 2008).

Among these six types of regulation, the degree to which an individual responds to a given mode of control is called the level of self-determination. In addition, heterogeneous behaviour can occur under the influence of external motives, depending on how much one's will is involved in carrying out tasks and making decisions. Intrinsic motivation can be raised by repeating the process in which the strength of self-regulation and autonomy gives meaning to task performance itself and leads to internalisation; the motivation for self-determination can also increase. In other words, in the process of internalization, various motives interact and coexist, so it can be seen that the motives are on a continuum.

**Table 1.** Types of motivation by degree of self-determination

Behaviour	Nonself-determined ←			→ Self-determined		
Motivation	Amotivation		Extrinsic motivation			Intrinsic motivation
Regulatory styles	Non-regulation	External regulation	Introjected regulation	Identified regulation	Integrated regulation	Intrinsic regulation
Perceived locus of causality	Impersonal	External	Somewhat external	Somewhat internal	Internal	Internal
Relevant regulatory processes	Nonintentional, Nonvaluing, Incompetence, Lack of control	Compliant, External reward and punishments	Self-control, Ego-involvement, Internal rewards and punishments	Personal Importance, Conscious valuing	Congruence, Awareness, Synthesis with Self	Interest, Enjoyment, Inherent satisfaction

*Adopted from Ryan & Deci (2000)*

Table 1 presents the motivation types according to self-determination on a continuum, and summarises the control styles, causal sources, and related control processes corresponding to each type of motivation. Table 1 shows that the motivation types appear in the order of amotivation, which has no causal origin for self-determination, external regulation, introjected regulation, identified regulation, integrated regulation, and intrinsic regulation, in which the order of self-determination and internal causality are gradually strengthened. Considering extrinsic motivation, from external regulation to integrated regulation, the individual feels the value of external stimuli more strongly. Considering integrated regulation, internalised behaviour is consistent and self-integrated.

In the meantime, research on the effect on academic achievement has been

conducted while discussing extrinsic and intrinsic motivation in terms of continuity by the STD theory. However, studies on various types of motivation according to self-determination that affect mathematics academic achievement have been insufficient. For this reason, this study analyzed the longitudinal trajectory of academic achievement in mathematics, learning motivation, and the degree of self-determination according to academic achievement in mathematics.

### III. METHODS

#### Participants

This study used student data from the 3rd (2014: 6th grade of elementary school) to 6th (2017: 3rd year of middle school) graders from the Gyeonggi Education Panel Study (GEPS) provided by the Gyeonggi Research Institute of Education in South Korea. GEPS aims to overcome the limitations of existing educational statistical data, where the survey was conducted only once or with different students each time (Kang et al, 2016). To this end, it was carried out to prepare the basis for policy improvement through various causal analyses by tracking various data on students' educational activities and lives as well as the characteristics of students, families, principals, teachers, and schools (Sung et al., 2012). In addition, in 2012 (1st year), the first survey was conducted targeting 4th graders in elementary school, 1st year students in middle school, and 1st year students in high school. Follow-up surveys are conducted every year until students graduate from high school and enter college or enter the labour market, and longitudinal data are being constructed for this population. Table 2 shows the students who participated in the survey from the 3rd year (6th grade in elementary school) to the 6th year (3rd year in middle school).

**Table 2.** Participants and time of survey

Year (Degree)	2014 (3rd)	2015 (4th)	2016 (5th)	2017 (6th)
Grade	Elementary school Grade 6	Middle school Grade 1	Middle school Grade 2	Middle school Grade 3
Number of students	3,441	5,740	5,607	5,464

In this study, a total of 2,649 students were selected by following up with all the surveyed students from the 6th grade to the 3rd year of middle school before proceeding with the analysis. They were selected by conducting a follow-up survey of students who had completed all the surveys from the 6th grade to the 3rd year of middle school before proceeding with the analysis. Therefore, this study was conducted with 2,649 students selected through a follow-up survey, and there were no missing values in the students' data. Among the students finally selected, 1,351 (51%) were male and 1,298 (49%) were female.

#### Analysis data and analysis variables

During the period from the 6th grade to the 3rd year of middle school, owing to the differences in learning content and level between grades, even if the raw score for

mathematics achievement is the same, academic achievement differs. Therefore, in this study, analysis was carried out using the mathematical vertical scale score instead of the raw score of mathematical academic achievement conducted during the period from the 6th grade to the 3rd year of middle school. The vertical scale score is a list of academic achievement scores on one developmental scale and is used when comparing grades is necessary (Kim et al., 2016). In this study, a comparison between grades was possible because the analysis of academic mathematics achievement was conducted using the mathematical vertical scale score.

As this study used GEPS longitudinal data of students, the questionnaire items on the characteristics of learning motivation were investigated based on students' perceptions. According to the degree of self-determination suggested by Ryan and Deci (2000), six types of motivation have been suggested (Table 1). However, five questions were presented on the types of motivation in GEPS, excluding regulation motivation. In addition, four questionnaires for each motive type were presented, with a total of 20 questions. Table 3 summarises the questionnaire items used in the study, and each questionnaire item is presented on a 5-point scale (1 = *not at all*, 2 = *disagree*, 3 = *neutral*, 4 = *agree*, 5 = *strongly agree*) (Kang et al., 2016).

**Table 3.** Questionnaire and explanation

Questionnaire	Explanation
Mathematical Vertical Scale Score	Mathematics used as academic achievement
Amotivation	① I don't know what I myself am doing at school.
	② I don't know why I should study.
	③ I honestly feel like I'm wasting my time in school.
	④ I don't know why I go to school.
External regulation motivation	① I study because my parents get angry if I don't study.
	② If I don't study, the teacher will punish me (rebuke, corporal punishment), so I study.
	③ I study because my parents tell me to do it.
	④ I study because my teacher tells me to do it.
Learning motivation	Introjected regulation motivation
	① I study because I feel embarrassed when my academic grades are bad.
	② I study because I don't want the teacher to ignore me.
	③ I study because I want my friends to see me as a smart student.
④ I study to beat my competition.	
Identified regulation motivation	① I study because I believe it is worthwhile to build up knowledge.
	② I study to learn things I don't know.
	③ I study because I think what I have learned will be useful in real life.
	④ I study because I think it will help me to understand more difficult content later.
Intrinsic regulation motivation	① I study because I enjoy gaining knowledge.
	② I study because studying is fun.
	③ I study because I get joy from difficult challenges.
	④ I study because I like to think.

In this study, the full information maximum likelihood (FIML) method was used for parameter estimation. As FIML can be used only when the conditions for multivariate normality are met, the variables were verified based on skewness and kurtosis. The absolute value of skewness for the sub-factors of the mathematical vertical scale score and learning motivation used in this study was less than 1.331, and the absolute value of kurtosis was less than 1.285. For the variables used in the study, if the absolute value for skewness was  $\leq 2$  and the absolute value for kurtosis was  $\leq 7$ , it did not affect the estimation of parameters when using the maximum likelihood method (Curran et al, 1996). Therefore, the items used in this study can be judged to satisfy both the standards of skewness and kurtosis and were thus suitable for SEM analysis.

Correlation analysis between all variables used in this study (mathematics vertical scale score, sub-factors for motivation factors) yielded absolute values of all correlation coefficients of 0.739 or less. In SEM, variables with absolute values whose correlation coefficients between variables exceed 0.95, may produce unstable solutions when analysed (Kline, 2016). However, the absolute value of the correlation coefficients between all variables used in this study was 0.739 or lower, indicating that there was no multicollinearity problem.

#### Factor-specific reliability of the sub-factors of learning motivation

Table 4 shows the test reliability for the learning motivation sub-factors used in this study. As a result of calculating the Cronbach coefficient for each of the four years, the minimum and maximum values were 0.842 and 0.925. Respectively in the social sciences, if the Cronbach coefficient is 0.6 or higher, reliability is considered adequate (Leech et al, 2014), and internal consistency is judged to hold. Therefore, as the Cronbach's  $\alpha$  for all variables from the 4th to the 6th order was 0.6 or higher, this survey is deemed reliable.

**Table 4.** Reliability by factor

Top factor	Sub-factor	Number of questions	Reliability (Cronbach's $\alpha$ )			
			3rd	4th	5th	6th
Learning motivation	Amotivation	4	0.887	0.894	0.897	0.893
	External regulation motivation	4	0.855	0.875	0.886	0.888
	Introjected regulation motivation	4	0.842	0.871	0.869	0.867
	Identified regulation motivation	4	0.883	0.877	0.885	0.876
	Intrinsic regulation motivation	4	0.904	0.915	0.921	0.925

#### Research methods and procedures

Data analysis was conducted using SPSS version 26, Mplus 7.3, and Microsoft Excel. First, descriptive statistical and correlation analyses were performed to understand the trends in the mathematical vertical scale score and sub-factors of learning motivation. Second, using LGM and MILGM, the longitudinal change trajectories of all students' mathematical vertical scale scores and sub-factors of learning motivation were analysed.



Third, growth mixture modeling (GMM) was performed to classify the study participants into groups with similar longitudinal change trajectories of mathematical vertical scale scores. Fourth, LGM was performed on the mathematical vertical scale scores of subgroups (latent classes) classified by GMM to compare and analyse longitudinal changes in each group. Fifth, MILGM was implemented for the sub-factors of learning motivation by group to compare and analyse longitudinal change in trajectories over time.

In this study, identification constraints were applied to the variance and covariance to minimise the classification and estimation errors that may appear in the allocation of latent classes when GMM is implemented. In addition, while increasing the number of latent classes individually, the information index, Lo–Mendell–Rubin adjusted likelihood ratio test (LMR–LRT), bootstrap likelihood ratio test (BLRT), and entropy were checked to determine the optimal number of latent classes.

The LGM and MILGM used in this study estimated unconditional models that did not include covariates. The model fits for the changeless, linear change, and quadratic nonlinear change models were compared, and the model with the best fit was finally selected. Verification utilising  $\chi^2$ , one of the absolute fit indices, was performed to determine the model conformance. Considering that the  $\chi^2$  test is sensitive to the sample size, the absolute fit indices of root mean square error of approximation (RMSEA), standardised root mean square residual (SRMR), and the incremental fit indices comparative fit index (CFI) and Tucker–Lewis index (TLI) were also used.

### **Latent growth model and multiple indicator latent growth model**

The latent growth model (LGM) is a method of analysing the longitudinal change trajectory of variables by estimating latent growth factors against data measured repeatedly over multiple points in time and analysing individual functions of change and resulting individual differences (Duncan & Duncan, 2004). LGM makes it possible to identify the variables that affect longitudinal change and analyse the group change trajectory (Duncan et al., 2006).

In general, LGM analysis is performed using a structural equation model (SEM) with a factor model that includes the mean of the observation variables measured repeatedly over time (Duncan & Duncan, 2004). Moreover, when the analysis is performed using the LGM, it is determined whether the longitudinal change trajectories of the measured variables are linear or nonlinear. In SEM using cross-sectional data investigated at a fixed point in time, the factors and path coefficients between each factor are the unknowns to be estimated. However, the LGM, with longitudinal data, uses the initial status and rate of change to determine the degree of change up to the last time point (Kim, 2020).

If the LGM shows a linear change trajectory similar to a linear function, the equation consists of a constant term (intercept) and slope value, as shown in Equation 2. To represent a nonlinear trajectory of change, such as a quadratic function, a quadratic term is added to Equation 2, as shown in Equation 3. If there is no longitudinal change (changelessness), it is sufficient to omit the linear term from Equation 2, as seen in Equation 1. The significance of the final linear expression can be determined using a significance test for each value.

$$y = \text{constant term (intercept)} \dots (1)$$

$$y = \text{constant term (intercept)} + (\text{slope})t + \varepsilon \dots (2)$$

$$y = \text{constant term (intercept)} + (\text{slope})t + (\text{quadratic})t^2 + \varepsilon \dots (3)$$

$\varepsilon$ : residual

In these equations, the constant term is the average value of the variables derived at the time of measurement (intercept: initial value), the slope is the degree of change (increase rate) of the average value with respect to time, and the coefficient of the quadratic equation is  $\frac{1}{2}$  for acceleration with respect to growth (Wang & Wang, 2019). To estimate the LGM, it is necessary to set the factor load for the measured variable, which is the load on latent factors. In general, regardless of the type of LGM, the intercept (initial value) factor of the measured variables has the same factor load and is fixed at 1. For the slope (rate of change) factor, the factor load of the measured variables was set to a constant with the same interval. The factor loading for the quadratic coefficient can be set as the square of the factor loading of the slope (rate of change) (Wang & Wang, 2019).

In this study, a changeless, linear change, and quadratic nonlinear change models were used to examine the longitudinal change trajectories for mathematical vertical scale scores. Figure 1 shows the LGM for the changeless, linear change, and quadratic nonlinear change models used in this study as an SEM.

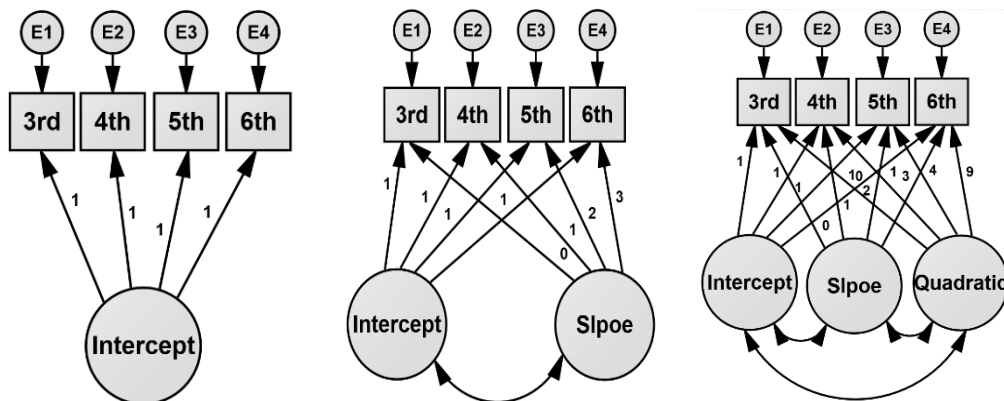

**Figure 1.** Latent growth model for mathematical vertical scale score

LGM was used to analyse the change trajectories of the single measured variables. Before using LGM, it is common to generate one indicator variable by calculating the average or summing up several observed variables for which the construct is measured and to use this indicator variable for analysis (Kim, 2020). A growth model that analyses changes after generating a single indicator for these changes in constructs is called single-indicator LGM. However, analysing the change trajectory of a construct by averaging or summing the measured variables is premised on the assumption that the measured variables measure the construct without error and have factorial invariance at different points in time (Kim, 2020). Therefore, if the single-indicator LGM violates these assumptions, the

parameter estimate is biased and the power of verification of the growth factor indicating the change trajectory is lowered (Bollen & Curran, 2006; Leite, 2007; Newsom, 2015). Conversely, the multiple indicator latent growth model (MILGM) is a second-order factor model that sets the constructive concept to a latent variable (primary factor) measured indirectly by several observation variables, and it sets the change trajectory of this latent variable as the upper growth factor (secondary factor). As this model sets the construct as a factor, it is possible to estimate the change trajectory of the construct by considering measurement errors and testing the factor identity of the observed variables (Bishop et al., 2015).

Despite the advantages of MILGM, most studies analysing the trajectory of change in the concept of composition have mainly used LGM, which utilises a single rather than multiple indicators (Bishop et al., 2015). Therefore, in this study, MILGM was used to examine the longitudinal change trajectories of the sub-factors of learning motivation. Figure 2 shows the quadratic nonlinear change model of the MILGM used in this study as an SEM. In Figure 2, if the quadratic coefficient is removed, it becomes a linear change model. If the slope and quadratic coefficient are removed, it becomes a changeless model.

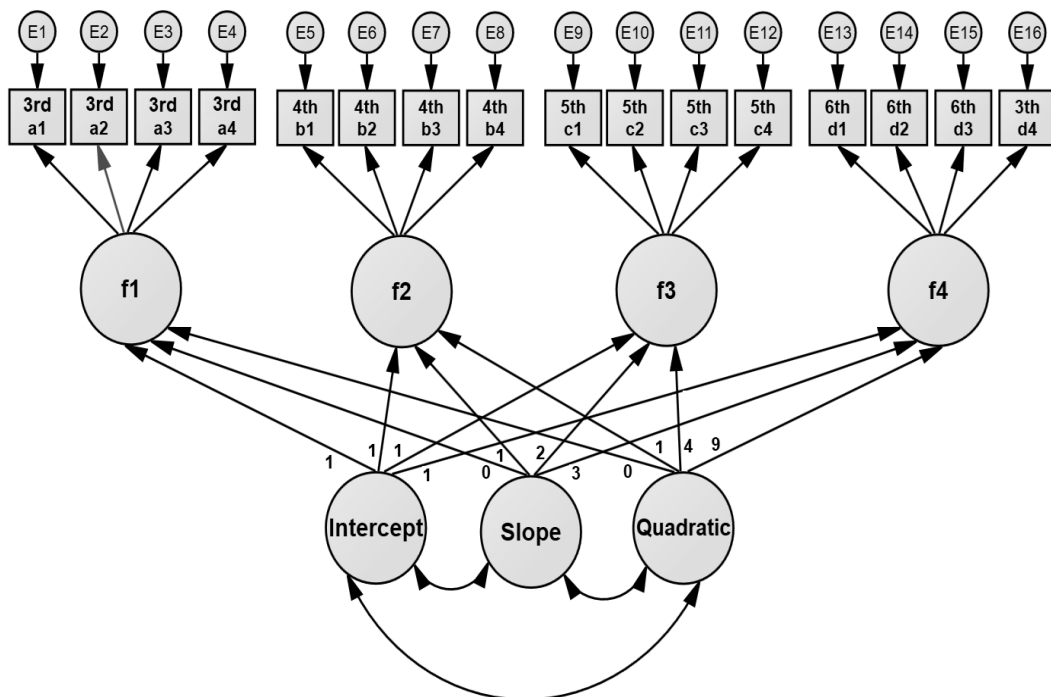

Figure 2. Multiple indicator latent growth model for motivation factors

### Research model

The research model applied in this study is presented in Figure 3.

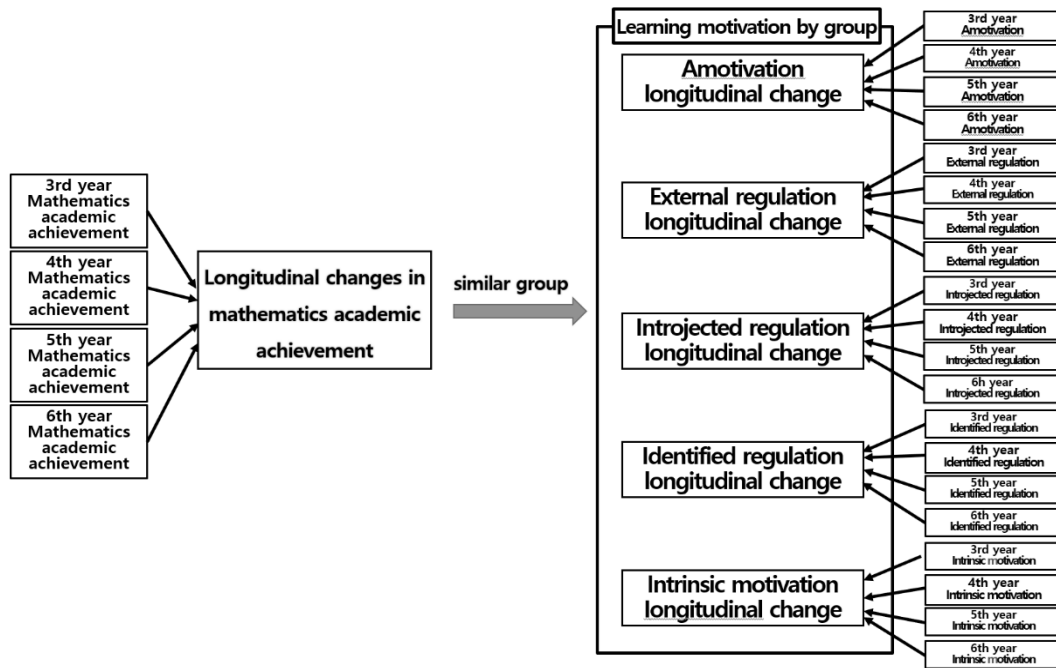

Figure 3. Research model

IV. RESULTS

**Longitudinal change trajectories for mathematical vertical scale scores and learning motivation**

LGM was implemented to examine the longitudinal change trajectories of the sub-factors of the mathematical vertical scale scores and learning motivation for the entire group. Figure 4 shows a graph using the estimates of the scores on the mathematical vertical scale for all the students. The mathematical vertical scale score continuously increased from the 6th grade in elementary school to the 3rd year in middle school.

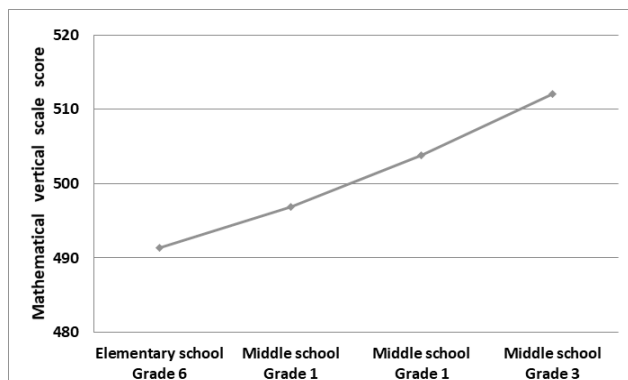
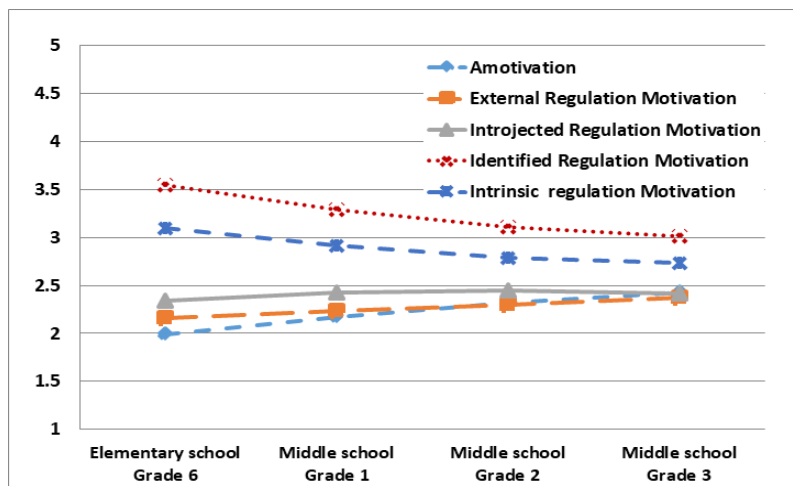

Figure 4. Latent growth model graph of math vertical scale scores for all students

Figure 5 shows the sub-factors of learning motivation for all students using MILGM estimates. As indicated, identified regulation motivation was the highest sub-factor of learning motivation during the period from 6th grade to 3rd year of middle school, followed by intrinsic regulation motivation. In addition, amotivation, external regulation motivation, and introjected regulation motivation were found to be similar. External regulation motivation and intrinsic regulation motivation decreased continuously from the 6th grade to the 3rd year of middle school, and amotivation and external regulation motivation increased continuously. Introjected regulation motivation slightly increased from the 6th grade to the 1st year of middle school but then remained similar until the 3rd year of middle school. In addition, for introjected regulation motivation and external regulation motivation, the range of change from the 6th grade to the 3rd year of middle school was narrow compared to other factors.



**Figure 5.** Multiple indicator latent growth model for each sub-factor of learning motivation for all students

### Classified into subgroups with similar trajectories of change of mathematical vertical scale scores

GMM was implemented to classify students with similar longitudinal change trajectories in mathematical vertical-scale scores into subgroups. After performing GMM using the linear change model and quadratic nonlinear change model, comparison and analysis showed that BMM using the quadratic nonlinear change model was more suitable for the number of latent classes and classification rate. Table 5 summarises the results. GMM evidently identifies up to five subgroups. However, with six or more subgroups, the classification of the group was not clear because a group with zero students (0%) emerged among the classified subgroups, so it was excluded from the group classification.

**Table 5.** Goodness of fit indicator of growth mixture modelling by group for mathematical vertical scale scores

Fit index	Group 1	Group 2	Group 3	Group 4	Group 5
AIC	122854.029	122463.060	122339.014	122165.665	122139.948
BIC	122930.494	122563.052	122462.534	122312.713	122310.525
SABIC	122889.189	122509.038	122395.811	122233.281	122218.383
Entropy		0.759	0.815	0.781	0.762
LMR-LRT <i>p</i> value		<0.0001*	0.0012*	<0.0001*	0.4776
number of students (classification rate: %)	Group 1	1580 (59.6%)	1023 (38.6%)	704 (26.6%)	284 (10.7%)
	Group 2	1069 (40.4%)	67 (2.5%)	754 (28.5%)	666 (25.1%)
	Group 3		1559 (58.9)	1090 (41.1%)	53 (2%)
	Group 4			101 (3.8%)	404 (15.3%)
	Group 5				1242 (46.9%)

AIC = Akaike information criterion, BIC = Bayesian information criterion,

SABIC = Sample Size Adjusted BIC ( $n^* = (n+2)/24$ ),

LMR-LRT = Lo-Mendell-Rubin Adjusted Likelihood Ratio Test,  $*=p < 0.05$

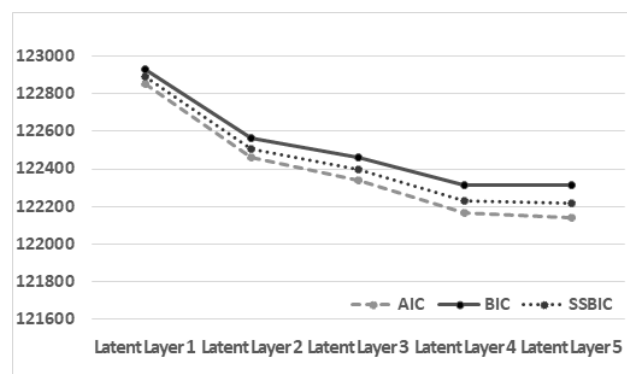
**Figure 6.** Changes in the information index by number of latent classes

Using the Akaike information criterion (AIC), Bayesian information criterion (BIC), and sample size adjusted BIC (SABIC) to optimally determine the number of lower latent classes (Table 5), it was found that the more the group was divided, the smaller the values (Figure 6). This means that the more the group was divided, the more appropriate the classification of the group. In addition, the LMR-LRT *p*-value was suitable for all classifications into two to four subgroups, and the entropy value for classification accuracy for the group was the highest when classified into three subgroups. The entropy value for the classification into four subgroups was 0.781, which was slightly lower than that for the classification into three subgroups. However, the information index values of AIC, BIC, and SABIC were lower than those classified into three subgroups, and the LMR-LRT *p*-value was significant; therefore, classification into four subgroups was selected. Among the four subgroups divided by GMM, one group (101 students, 3.8%) was found to have a low number of students. However, according to Prislin (2022), special aspects of human

behaviour should be studied even in minority groups; thus, this study was conducted by including them in group classification. The entropy value indicates the quality of the classification of the entire group into a lower group, which can be judged as appropriate if  $>0.8$ . However, this value decreases as the sample size increases (Wang et al., 2017). In this study, the entropy value was slightly lower because it was classified into subgroups using data from 2,649 students, which is a rather large number.

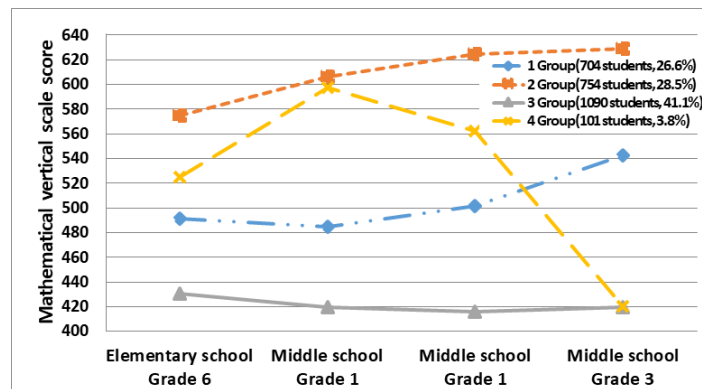

**Figure 7.** Latent growth model for each group's mathematical vertical scale score

Figure 7 shows a graph of the LGMs of the four subgroup mathematical vertical scale scores classified by GMM. The mathematical vertical scale scores of Group 1 decreased slightly from the 6th grade of elementary school to the 1st year of middle school and then increased until the 3rd year of middle school. The mathematical vertical scale scores of Group 2 continued to increase from the 6th grade to the 3rd year of middle school. The mathematical vertical scale scores of Group 3 (1090 students, 41.1%), including the majority of students, continued to decrease from the 6th grade to the 2nd year of middle school, but slightly increased in the 3rd year of middle school. From the 1st year to the 3rd year of middle school, the change in the mathematical vertical-scale scores of the students in Group 3 was insignificant. The mathematical vertical-scale scores of Group 4 (101 students), which included 3.8% of all students, increased from the 6th grade to the 1st year of middle school and then decreased until the 3rd year of middle school. A significant decrease occurred from the 2nd to the 3rd year of middle school.

During the period from the 1st to the 3rd year of middle school, Group 2 showed the largest increase in mathematical vertical-scale scores, and the mathematical vertical-scale scores of Group 3 appeared to decrease slightly. In addition, the change in mathematical vertical-scale scores showed that Group 4, a small group (101 students, 3.8%), had the largest change in mathematical vertical scale scores, followed by Groups 2, 1, and 3. Apart from Group 4, the mathematical vertical scale scores from the 6th grade to the 3rd year of middle school were high in the order of Group 2 (754 students, 28.5%), Group 1 (704 students, 26.6%), and Group 3 (1090 students, 41.1%). From this, it seems that Group 2 includes high-level students, Group 1 includes middle-level students, and Group 3 includes low-level students.

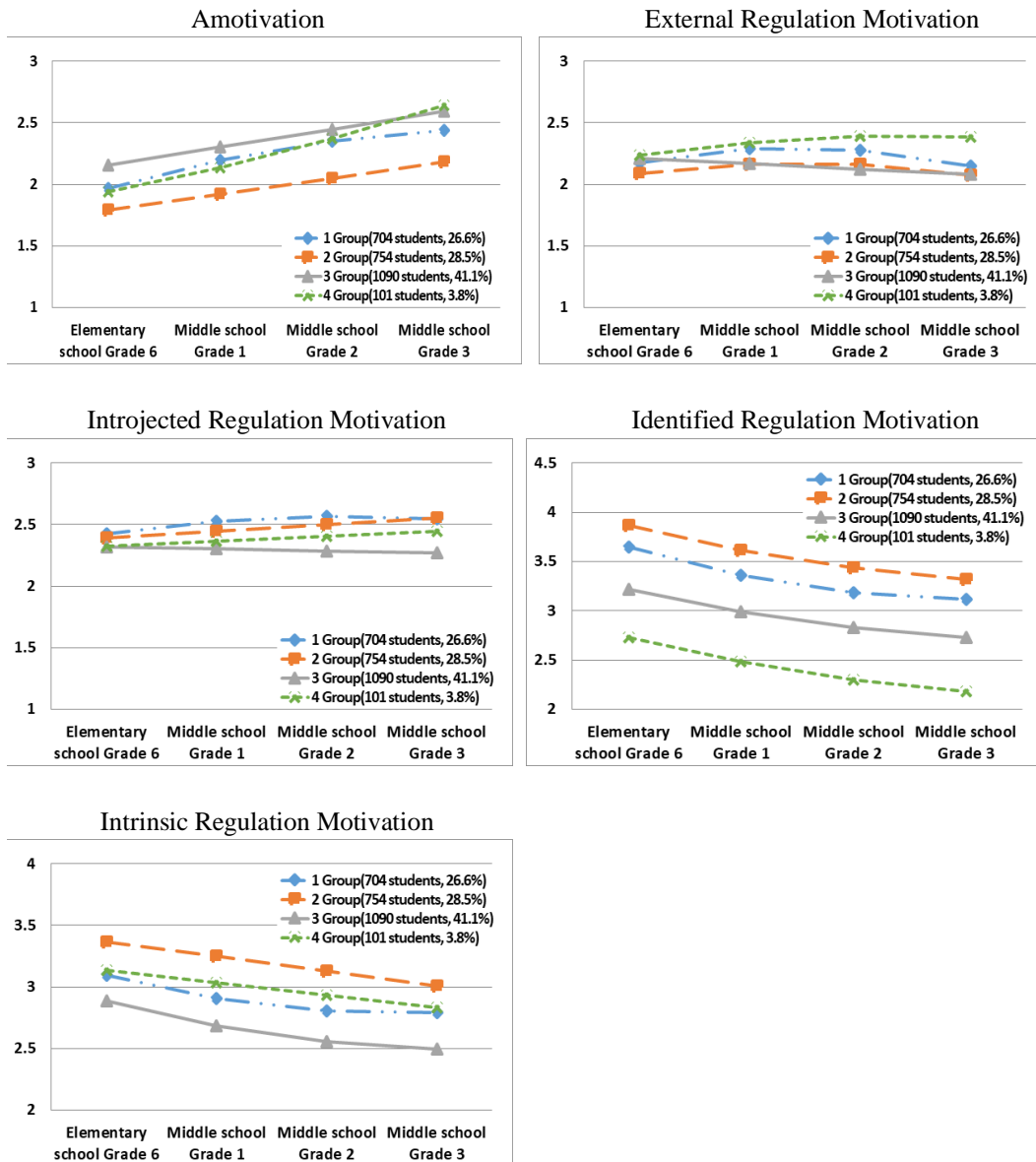

**Figure 8.** Multiple indicator latent growth model graph of motivation type according to the degree of self-determination by group

Figure 8 presents a graph of the MILGM of motivational types according to the degree of self-determination by the group from the 6th grade to the 3rd year of middle school. It was found that amotivation continued to increase in all groups from the 6th grade to the 3rd year of middle school. In addition, Group 2 was the lowest during the period from the 6th grade to the 3rd year of middle school and, apart from Group 4 (101 students, 3.8%), Group 3 (1090 students, 41.1%) with the majority of students, the highest. In addition, except for Groups 4 (101 students, 3.8%), which included a small number of



students from the 6th grade elementary school to the 3rd year of middle school, there were Group 2 (high-level), Group 1 (middle-level), and Group 3 (low-level) that came out in high order. The amotivation of the Groups 4 of students showed the greatest increase.

External regulation motivation was found to be similar in all groups in the 6th grade, but Group 4 showed a slight continuous increase until the 3rd year of middle school. Throughout the period from the 6th grade to the 3rd grade of middle school, Groups 1, 2, and 3 showed little change. That is, external regulation motivation in the 6th grade was similarly maintained until the 3rd grade of middle school.

Introjected regulation motivation was found to be similar for all groups in the sixth grade, and Groups 1, 2, and 4 showed a slight continuous increase from the 6th grade to the 3rd year of middle school. In addition, the introjected regulation motivation of Group 3 (1090 students, 41.1%) with the majority of students was found to be similarly maintained at its value in 6th grade until the 3rd year of middle school.

The identified regulation motivation and intrinsic regulation motivation continued to decline in all groups from the 6th grade to the 3rd year of middle school. In addition, from the 6th grade to the 3rd year of middle school, the identified regulation motivation was found to be highest in the order of Groups 2, 1, 3, and 4, respectively, and intrinsic regulation motivation was found to be highest in the order of Groups 2, 4, 1, and 3.

Examining the motivation types according to mathematical vertical scale scores during the period from 6th grade to 3rd year of middle school, amotivation was higher in Group 2 (high level), Group 1 (middle level), and Group 3 (low level). In addition, external regulation motivation was found to be similar in Group 2 (high level), Group 1 (middle level), and Group 3 (low level). Introjected regulation motivation Groups 1, 2, and 4 showed a slight continuous increase, Group 3 (1090 students, 41.1%) with the majority of students was found to be similarly maintained at its value in 6th grade until the 3rd year of middle school. In the identified regulation motivation and intrinsic regulation motivation continued to decline in all groups, Group 2 (high-level) was the highest, followed by Group 3 (low-level) and Group 1 (middle-level).

## V. DISCUSSION AND CONCLUSION

This study examined the trajectory of longitudinal change in learning motivation types according to the trajectory of longitudinal change in academic achievement in mathematics. Based on the previous analysis, the following conclusions can be made.

First, from the 6th grade to the 3rd year of middle school, the identified and intrinsic regulation motivation for the whole group continued to decrease, while external and introjected regulation motivation appears to remain almost unchanged. As identified regulation motivation and intrinsic regulation motivation refer to states of high self-determinism. Therefore, the results of this study suggest that Korean students' self-determination decreases as the grade level increases. The result of a continuous decrease in intrinsic regulation motivation supports the findings of previous studies (Deci & Ryan, 2008; Guay, 2022) that intrinsic motivation decreases as the grade level increases. In

addition, if we consider that self-determination decreases from the 6th grade to the 1st year of junior high school, it can be seen that self-determination decreases even when the school level changes from elementary to junior high school. The results of this study, external and introjected regulation motivation appears to remain almost unchanged from the 6th grade to the 3rd year of middle school. From these results, it can be seen that there is no significant change in the intrinsic regulatory motivation and external regulatory motivation established in the 6th grade of elementary school.

The results of this study showed that identified regulation motivation with a high self-determination level and intrinsic regulation motivation accounted for a high ratio, while external regulation motivation with a low self-determination level accounted for a low ratio. These results are similar to those reported by Lim and Ryu (2007) for South Korean students. In other words, it can be seen that South Korean students have a higher proportion of motives with high self-determination than motives with low self-determination.

Second, the whole group that self-determination decreases as the years of study increase, and amotivation continues to increase. These results show that there is an inverse relationship between self-determination and amotivation among Korean students as their grade level increases. In addition, considering that the results are the same from the 6th grade to the 1st year of junior high school, even if the school level changes from elementary school to middle school, it can be seen that self-determination and amotivation have an inverse relationship. Research by Ryan and Deci (2000, 2017) shows that students who are high self-determination are highly motivated. High motivation can also have a positive effect on academic achievement (Ryan & Deci, 2020). Therefore, in order to increase self-determination, it is believed that in-depth research will be needed to examine the correlation between self-determination and amotivation based on this study in the future.

Third, the students' mathematical vertical scale scores were classified into four subgroups with similar longitudinal trajectories. These empirical results support previous studies (Kim, 2020; Mok et al., 2015; Perez Mejias et al., 2021) suggesting that various longitudinal change trajectories can appear in mathematics academic achievement, reflecting students' characteristics and propensities. In particular, when looking at the mathematical vertical scale scores by the group from the 6th grade to the 3rd year of middle school, except for Group 4 (201 students, 3.8%) with a low number of students, the order of high-level Group 2 (754 students, 28.5%), middle-level Group 1 (704 students, 26.6%), and low-level Group 3 (1090 students, 41.1%) was maintained. In addition, the increasing width of the mathematical vertical scale scores was found to be higher at the high level (Group 2) and middle level (Group 1) as the grade level increased. The low-level (Group 3) group, containing 41.1% or a plurality of students, showed a slight decline from the 6th grade to the 3rd year of middle school. These results reflect the characteristics of mathematics, which emphasise systematicity. That is, owing to the nature of mathematics classes, previously mastered learning reinforces subsequent learning (Kim, 2020). Therefore, students with high mathematics academic achievement in the 6th grade showed greater improvement in mathematics academic achievement from the later grades to the 3rd year of middle school. For this reason, for the continuous improvement of mathematics

academic achievement, it is thought that mathematics academic achievement in lower grades, such as the 6th grade, is very important.

Furthermore, when we exclude the small group of Group 4 (201 students, 3.8%) from the results of this study, show that owing to the systematic nature of mathematics, stagnation or deficit in mathematics learning in lower grades may continue to affect subsequent mathematics learning, and stagnation or deficit in mathematics learning may occur. Therefore, support for teaching and learning is very important for students who have a deficit or stagnation in math learning in lower grades, such as elementary school, and it is also necessary to study realistic support measures in schools. In addition, because many factors affect academic achievement in mathematics (Shin et al., 2009; Kim, 2020), deeper studies of various factors are required to generalise the results of this study.

Fourth, from the 6th grade to the 3rd year of middle school, identified regulation motivation and intrinsic regulation motivation were the highest in high-level group 2, middle-level group 1, and low-level group 3. Furthermore, In the 6th grade, external regulation motivation and introjected regulation motivation were similar in all groups, and the range of change was narrow between the 6th grade and the 3rd year of middle school. As identified regulation motivation and intrinsic regulation motivation indicate a state of high self-determination, external regulation motivation and introjected regulation motivation refer to states of low self-determination. In the results by group showed that identified regulation motivation with a high self-determination level and intrinsic regulation motivation accounted for a high ratio, while external regulation motivation with a low self-determination level accounted for a low ratio. Given these results, the higher the mathematical vertical scale score, the higher the self-determination. In addition, amotivation was the highest in groups 3 (low-level), 1 (middle-level), and 2 (high-level) during the 6th grade to the 3rd year of middle school. This suggests that the higher the group with the lower mathematics achievement, the higher the amotivation. These results suggest that it is necessary to increase self-determination and lower amotivation in order to improve academic achievement in mathematics. Therefore, in order to further improve the academic achievement mathematics of Korean students in mathematics, it is thought that it is necessary to reduce apathy and increase self-determination, and research on realistic support measures for this is also necessary.

Fifth, in Group 4, with only 3.8% (101 students) of the students, mathematical vertical scale scores increased the most from the 6th grade to the 1st year of middle school, once the school-level transfer period ended, it decreased continuously since the 1st year of middle school. In addition, extrinsic motivation (external regulation motivation and introjected regulation motivation) with low self-determination increased slightly as grade level increased, but motivation with high self-determination (identified regulation motivation and intrinsic regulation motivation) continued to decrease. And the most significant increase in amotivation during the entire period, with a significant decrease in math vertical scale scores beginning in middle school. These results, it can be considered that the school-level movement affected the mathematics learning and self-determination of students in group 3, resulting in a continuous decrease in mathematical vertical scale scores even after the school-level movement. However, because the factors affecting

academic achievement in mathematics are diverse (Shin et al., 2009; Kim, 2020) a more intensive study of related factors is needed in the future.

Limitations of this study and suggestions for future research include the following.

First, as this study was conducted using data from elementary and middle school students in a specific area of Korea, there may be limitations in applying the results of this study to students and high school students in other areas. Therefore, in the future, it will be necessary to conduct research on students from various regions as well as on high school students. Second, the motivation-type questionnaire on the degree of self-determination administered in GEPS in Korea covered all subjects. As self-determination may differ even across individual subjects, questionnaires should be administered suited to the characteristics of the respective subject, such as mathematics, in the future. Third, a longitudinal analysis was performed using LGM and MILGM. Therefore, to support the results of this study, a cross-sectional study at each grade level is needed to verify these results. Fourth, because this was a longitudinal study, the analysis used past data, which may limit the generalisability of this study. Therefore, more recent data should be used in future studies. Fifth, in the previous study, Ryan and Deci (2000) categorized six types of motivation (see Table 1.), but GEPS in Korea excluded External Regulation Motivation and categorized it into five types. In the future, it is necessary to add External Regulation Motivation to the survey for in-depth research.

## REFERENCES

- Bishop, J., Geiser, C., & Cole, D. A. (2015). Modeling latent growth with multiple indicators: A comparison of three approaches. *Psychological Methods, 20*(1), 43-62. <https://doi.org/10.1037/met0000018>
- Bollen, K. A., & Curran, P. J. (2006). *Latent curve models: A structural equation perspective*. John Wiley & Sons.
- Chan, D. K. C., Yang, S. X., Hamamura, T., Sultan, S., Xing, S., Chatzisarantis, N. L., & Hagger, M. S. (2015). In-lecture learning motivation predicts students' motivation, intention, and behaviour for after-lecture learning: Examining the trans-contextual model across universities from UK, China, and Pakistan. *Motivation and Emotion, 39*(6), 908-925. <https://doi.org/10.1007/s11031-015-9506-x>
- Curran, P. J., West, S. G., & Finch, J. F. (1996). The robustness of test statistics to nonnormality and specification error in confirmatory factory analysis. *Psychological Methods, 1*(1), 16-29. <https://doi.org/10.1037/1082-989X.1.1.16>
- Deci, E. L., & Ryan, R. M. (1985). The general causality orientations scale: Self-determination in personality. *Journal of Research in Personality, 19*(2), 109-134. [https://doi.org/10.1016/0092-6566\(85\)90023-6](https://doi.org/10.1016/0092-6566(85)90023-6)
- Deci, E. L. & Ryan, R. M. (2000). The 'What' and 'Why' of goal pursuits: Human needs and the self-determination of behavior. *Psychological Inquiry, 11*(4), 227-229. [https://doi.org/10.1207/S15327965PLI1104\\_01](https://doi.org/10.1207/S15327965PLI1104_01)
- Deci, E. L., & Ryan, R. M. (2008). Self-determination theory: A macrotheory of human

- motivation, development, and health. *Canadian Psychology / Psychologie Canadienne*, 49(3), 182-185. <https://doi.org/10.1037/a0012801>
- Diseth, Å., Mathisen, F. K. S., & Samdal, O. (2020). A comparison of intrinsic and extrinsic motivation among lower and upper secondary school students. *Educational Psychology*, 40(8), 961-980. <https://doi.org/10.1080/01443410.2020.1778640>
- Duke, N. K., Halvorsen, A. L., Strachan, S. L., Kim, J., & Konstantopoulos, S. (2021). Putting PjBL to the test: The impact of project-based learning on second graders' social studies and literacy learning and motivation in low-SES school settings. *American Educational Research Journal*, 58(1), 160-200. <https://doi.org/10.3102/0002831220929638>
- Duncan, T. E., & Duncan, S. C. (2004). An introduction to latent growth curve modeling. *Behavior Therapy*, 35(2), 333-363. [https://doi.org/10.1016/S0005-7894\(04\)80042-X](https://doi.org/10.1016/S0005-7894(04)80042-X)
- Duncan, T. E., Duncan, S. C., & Strycker, L. A. (2013). *An introduction to latent variable growth curve modeling: Concepts, issues, and applications*. Routledge.
- Filgona, J., Sakiyo, J., Gwany, D. M., & Okoronka, A. U. (2020). Motivation in learning. *Asian Journal of Education and Social Studies*, 10(4), 16-37. <https://doi.org/10.9734/ajess/2020/v10i430273>
- Geary, D. C. (2011). Cognitive predictors of achievement growth in mathematics: A 5-year longitudinal study. *Developmental Psychology*, 47(6), 1539-1552. <https://doi.org/10.1037/a0025510>
- Guay, F. (2022). Applying self-determination theory to education: Regulations types, psychological needs, and autonomy supporting behaviors. *Canadian Journal of School Psychology*, 37(1), 75-92. <https://doi.org/10.1177/08295735211055355>
- Kang, H. S., Kim, H. D., Lee, H. Y., & Kim, B. J. (2016). *Development of items in the 5th year of the Gyeonggi education longitudinal study*. Gyeonggi Education Research Institute
- Kim, A. Y., & Oh, S. A. (2001). Classification of Motivation on the Continuum of Self-Determination. *Journal of Education Psychology*, 15(4), 97-119.
- Kim, S. H., Kang, D. H., Moon, S. M., Yoon, W. S., & Park, S. H. (2016). *Research on the achievement score for the academic achievement test for the 7th year Seoul National University of Education*. Seoul Institute for Education Policy.
- Kim, Y. S. (2020). *A longitudinal study on the effect of learner's internal and external factors on mathematics academic achievement: For middle and high school students*. Doctoral thesis, Sungkyunkwan University.
- Kline, R. B. (2016). *Principles and practice of structural equation modeling* (4th ed.). Guilford Press.
- Lee, M. B. (2003). *The effect of self-determination motivation and self-regulated learning on academic achievement*. Master's thesis, Yonsei University.
- Leech, N. L., Barrett, K. C., & Morgan, G. A. (2014). *IBM SPSS for intermediate statistics: Use and interpretation*. Routledge.
- Little, T. D. (2013). *Longitudinal structural equation modeling*. Guilford Press.
- Mok, M. M., McInerney, D. M., Zhu, J., & Or, A. (2015). Growth trajectories of mathematics achievement: Longitudinal tracking of student academic progress. *British Journal of*

- Educational Psychology*, 85(2), 154-171. <https://doi.org/10.1111/bjep.12060>
- Newsom, J. T. (2015). *Longitudinal structural equation modeling: A comprehensive introduction*. Routledge.
- Perez Mejias, P., McAllister, D. E., Diaz, K. G., & Ravest, J. (2021). A longitudinal study of the gender gap in mathematics achievement: evidence from Chile. *Educational Studies in Mathematics*, 107(3), 583-605. <https://doi.org/10.1007/s10649-021-10052-1>
- Pintrich, P. R., & Schunk, D. H. (2002). *Motivation in education: Theory, research, and applications*. Prentice Hall.
- Prislin, R. (2022). Minority influence: An agenda for study of social change. *Frontiers in Psychology*, 13, 911654. <https://doi.org/10.3389/fpsyg.2022.911654>
- Ryan, R. M., & Deci, E. L. (2000). Self-determination theory and the facilitation of intrinsic motivation, social development, and well-being. *American Psychologist*, 55(1), 68-78. <https://doi.org/10.1037/0003-066X.55.1.68>
- Ryan, R. M., & Deci, E. L. (2017). *Self-determination theory: Basic psychological needs in motivation, development, and wellness*. Guilford Publications.
- Ryan, R. M., & Deci, E. L. (2020). Intrinsic and extrinsic motivation from a self-determination theory perspective: Definitions, theory, practices, and future directions. *Contemporary Educational Psychology*, 61, 101860. <https://doi.org/10.1016/j.cedpsych.2020.101860>
- Shin, J., Lee, H., & Kim, Y. (2009). Student and school factors affecting mathematics achievement: International comparisons between Korea, Japan and the USA. *School Psychology International*, 30(5), 520-537. <https://doi.org/10.1177/0143034309107070>
- Sung, K. S., Kim, J. Y., Park, S. Y., & Min, B. C. (2012). *Gyeonggi education longitudinal research rese math academic achievement, learning motivation, self-determination theory, growth mixture modelling, latent growth model arch design and item development research*. Korea Education Research Network.
- Tremblay-Wragg, É., Raby, C., Ménard, L., & Plante, I. (2021). The use of diversified teaching strategies by four university teachers: What contribution to their students' learning motivation? *Teaching in Higher Education*, 26(1), 97-114. <https://doi.org/10.1080/13562517.2019.1636221>
- Wang, M.-C., Deng, Q., Bi, X., Ye, H., & Yang, W. (2017). Performance of the entropy as an index of classification accuracy in latent profile analysis: A Monte Carlo simulation study. *Acta Psychologica Sinica*, 49(11), 1473-1482. <https://doi.org/10.3724/SP.J.1041.2017.01473>
- Wang, J., & Wang, X. (2019). *Structural equation modeling: Applications using Mplus*. John Wiley & Sons.
- Zaccone, M. C., & Pedrini, M. (2019). The effects of intrinsic and extrinsic motivation on students learning effectiveness. Exploring the moderating role of gender. *International Journal of Educational Management*, 33(6), 1381-1394. <https://doi.org/10.1108/IJEM-03-2019-0099>
- Zheng, Y., Ye, X., & Hsiao, J. H. (2022). Does adding video and subtitles to an audio lesson facilitate its comprehension? *Learning and Instruction*, 77, 101542. <https://doi.org/10.1016/j.learninstruc.2021.101542>