



Original Article

Reliability analysis of nuclear safety-class DCS based on T-S fuzzy fault tree and Bayesian network

Xu Zhang^{*}, Zhiguang Deng, Yifan Jian, Qichang Huang, Hao Peng, Quan Ma

Science and Technology on Reactor System Design Technology Laboratory, Nuclear Power Institute of China, Chengdu, 610213, China

ARTICLE INFO

Article history:

Received 31 May 2022

Received in revised form

13 January 2023

Accepted 30 January 2023

Available online 1 February 2023

Keywords:

T-S fuzzy fault tree

Bayesian network

Reliability analysis

ABSTRACT

The safety-class (1E) digital control system (DCS) of nuclear power plant characterized structural multiple redundancies, therefore, it is important to quantitatively evaluate the reliability of DCS in different degree of backup loss. In this paper, a reliability evaluation model based on T-S fuzzy fault tree (FT) is proposed for 1E DCS of nuclear power plant, in which the connection relationship between components is described by T-S fuzzy gates. Specifically, an output rejection control system is chosen as an example, based on the T-S fuzzy FT model, the key indicators such as probabilistic importance are calculated, and for a further discussion, the T-S fuzzy FT model is transformed into Bayesian Network (BN) equivalently, and the fault diagnosis based on probabilistic analysis is accomplished. Combined with the analysis of actual objects, the effectiveness of proposed method is proved.

© 2023 Korean Nuclear Society, Published by Elsevier Korea LLC. This is an open access article under the CC BY-NC-ND license (<http://creativecommons.org/licenses/by-nc-nd/4.0/>).

1. Introduction

Nuclear power is playing an important role in the energy structure in China, based load for grid mainly provided by nuclear power plants. Some countries in America and Europe rise in nuclear power as the main power source, according to relevant data show that the French nuclear power has accounted for more than 70%. Therefore, guarantee the safe operation of nuclear power plant is an important research subject.

The reactor trip system (RTS) would be instantly triggered before the reactor lost control, and is the key equipment to ensure the nuclear power plants keep safe. Currently, nuclear safety-class DCS (1E DCS) are commonly used in automatic control and safety insurance for nuclear power plants. Because of pivotal character of 1E DCS, the 1E DCS failure would lead to serious consequences. As shown in the statistical data published by the Nuclear Regulatory Commission (NRC), the failure of DCS accounted for about 8% of License Event Report (LER) and 9% of shutdown events from 1994 to 1999 [1]. Therefore, the health of the RTS in the 1E DCS must be accurately assessed.

1E DCS is the core part to maintain the operation of nuclear power plants and is an important guarantee for the safe and stable operation. If the 1E DCS fails seriously, it may lead to unplanned

shutdown, which may not only cause huge economic losses, but also lead to nuclear safety incidents. Therefore, it is of great significance to carry out condition maintenance on 1E DCS. The basis of condition maintenance is quantitative evaluation the reliability of system.

The commonly used reliability analysis methods include mechanism modeling method, data driven method and hybrid method. The typical mechanism modeling method is failure mode and effects analysis (FMEA) method, fault tree (FT) and so on, and the mechanism model of the system is established from the aspects of system connection relationship and fault causes, it is usually applied for qualitative analysis. Data-driven methods include statistical method and artificial intelligence method, such as Weibull distribution. Reliability analysis technology based on data-driven method is relatively simply to be realized, but it is not suitable for equipment such as DCS where electronic devices occupy the main proportion, the distribution model often poor with accuracy. Based on the characteristic of 1E DCS, such as a large number of redundant backups, composed of electric devices, an hybrid method need to be applied. Dynamic FT can describe the above redundancy loss, such as T-S fuzzy FT, which can better express the polymorphism, fuzziness and uncertainty of fault logic relationship [2–4], and the mechanism model and statistical factors are both considered. The combination of T-S fuzzy FT and reliability analysis has achieved many achievements in theoretical research and application.

In theoretical research, Feng Zhang proposes a new operation

^{*} Corresponding author.

E-mail address: zhangxu020354@foxmail.com (X. Zhang).

Nomenclature			
1E	safety-class	π_Q	quality factor
DCS	digital control system	BN	Bayesian Network
ESFAS	engineered safety features actuation system	DO	digital output module
FT	fault tree	f	center of the support set of fuzzy numbers
Gr.1	subgroup one	FMEA	failure mode and effects analysis
$I_q^j(x_i^j)$	probabilistic importance of the failure degree x_i^j	Gr.2	subgroup two
PACS	priority actuator control system	IP	protection channel I
RTS	reactor trip system	PIPS	protection instrument pre-process system
λ_b	fundamental failure rate	SICS	safety information and control system
π_C	structure factor	λ_p	work failure rate
		π_E	environment factor

method based on the universal grey number to overcome the shortcomings [5]. C-RISE, Memorial University, Canada has made contribution in the area of safety and risk analysis, such as advanced mechanistic model, R-vine model [6], event tree [7], belief-based Bayesian network [8]. Chen Wu transformed T-S fuzzy FT into Bayesian Network (BN), realizing two-way search between upper and lower layers of FT [9].

In terms of theoretical application, Chen Dongning designed the method of “reliability prediction and design-fault analysis and diagnosis-reliability analysis and evaluation”, applied T-S fuzzy FT to hydraulic cylinder synchronization system, and verified it with various importance evaluation indexes [10,11]. Sun Lina used T-S fuzzy FT and converts it into BN to analyze and model the interactive Ethernet (AFDX) of avionics system to solve its performance reliability under multiple fault states [12]. Yao Chengyu used various importance analysis methods to evaluate the importance of each component in system, and designed a fault search strategy using T-S fuzzy FT, which overcame the limitation of two-state hypothesis in fault search of traditional FT and increased the accuracy of fault search results [13–15]. T-S fuzzy FT has also been applied in other fields [16–19]. In addition, other fault analysis methods have been studied by some scholars [20–22].

In view of the highly redundant characteristics and clear system hierarchy of 1E DCS, FT is an effective method, and in order to achieve quantitative evaluation, T-S fuzzy gates are introduced. There are very few scholars have introduced the T-S fuzzy FT method into the reliability analysis of 1E DCS. In this paper, T-S FT is used to model the reliability of 1E DCS, the redundancy loss of 1E DCS is described, the importance of each part is analyzed, and its equivalent is converted into BN, and then the characteristic of BN is used to make up for the deficiency of T-S FT model.

The rest part of paper is arranged as below: Chapter 1 introduces the 1E DCS. Chapter 2 introduces the reliability analysis method based on T-S fuzzy FT. In the Chapter 3, the reliability modeling of typical DCS sub-system is carried out by using proposed method, including T-S fuzzy FT model and BN model. Chapter 4 the simulation results are discussed. At last, Chapter 5 concluded the works. The flow chart of reliability analysis of 1E DCS is as shown in Fig. 1.

2. Introduction of 1E DCS

DCS in nuclear power plant includes 1E DCS and non-classified DCS. Among them, 1E DCS realizes the emergency shutdown and post-accident treatment functions of nuclear power plants under accident conditions, and plays an important role in maintaining the safe and stable operation. The 1E DCS is composed of a series of control stations, which adopt digital technology based on functional modules. Each control station is physically composed of cabinet, board card, relay, air switch and other components. The 1E

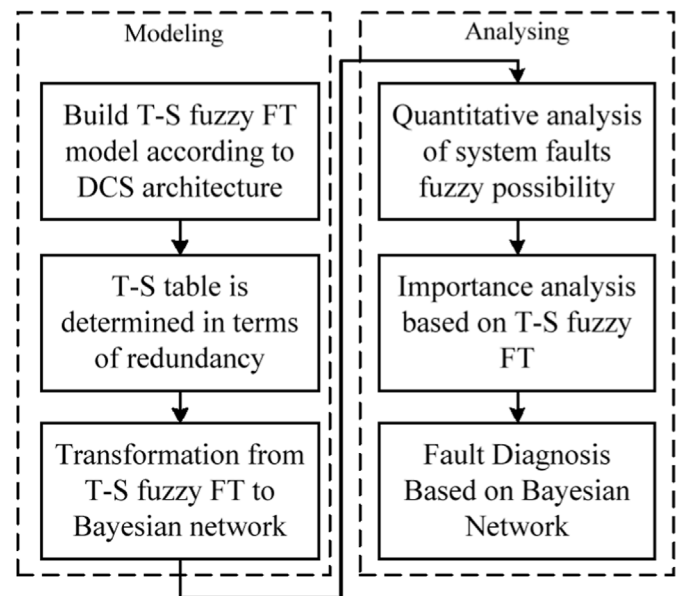

Fig. 1. Flow chart of reliability analysis of 1E DCS.

DCS receives the signals from the field sensors, outputs the signals back to the field after processing, so as to drive the reactor trip breaker and other actuator mechanisms to realize its safety protection function. In order to achieve higher reliability, 1E DCS adopts the design principle of multiple redundancies. Its RTS consists of four channels, each channel includes two redundant subgroups, and each subgroup includes a master controller and a slave controller with a hot-standby relationship. The output of the controller drives the shutdown circuit breaker through the digital output (DO) module and the relay, and realizing the shutdown function. The typical control station of 1E DCS is shown in Fig. 2.

1E DCS consists of four protection channels (IP–IVP) and two logical sequences (TRAIN A – TRAIN B), where each protection channel consists of two subgroups. It is divided into functions, including RTS, engineered safety features actuation system (ESFAS), priority actuator control system (PACS), protection instrumentation pre-processing system (PIPS), safety information and control system (SICS) and so on. Among them, the RTS consists of four channels, and the sensor signals are sent to the logical processing cabinet (RPC) of the channel after the conditioning, isolation and distribution of a channel. When the measured value of one protection group exceeds the set value range, the local trip signal generated by this channel will be transmitted to the other three



Fig. 2. 1E DCS

channels, and the shutdown signal of this channel will be generated according to the shutdown voting logic (2 out of 4). There are 4 sets of reactor trip breakers, which are controlled by each protection channel. When 2 sets of them are opened, the reactor will be shutdown. The architecture of 1E DCS is as shown in Fig. 3.

3. Reliability analysis based on T-S fuzzy fault tree

3.1. T-S fuzzy fault tree technology

FT analysis method is a graphical analysis method to find the cause of the specified fault (top event) from top to bottom, and presents the relationship of basic events in the form of logical graph. FT is an inverted logical causal diagram composed of top event, logic gates (AND gate, OR gate, XOR gate, etc.), basic events, etc. The FT takes the analyzed object as the top event and analyzes layer by layer from top to bottom.

The relationship between nodes in the traditional FT is composed of AND-OR gates and other logics. This logical representation method cannot reflect the polymorphism and fuzziness of events well. For example, in the case of double redundancy, the two constitute OR logic. When one of them fails, the OR gate still outputs true, which cannot indicate the loss of backup. The simple AND-OR gate is replaced by T-S fuzzy gate to form T-S fuzzy FT, which has a more specific expression of the complexity of system faults.

In T-S fuzzy FT, the failure probability and failure degree of components are described by the fuzzy number between [0,1]. The commonly used membership function is trapezoidal membership function. f is the center of the support set of fuzzy numbers, $\mu(x)$ is the membership function, s_l and s_r are the support radius, and m_l and m_r are fuzzy regions. Membership function for fuzzy numbers

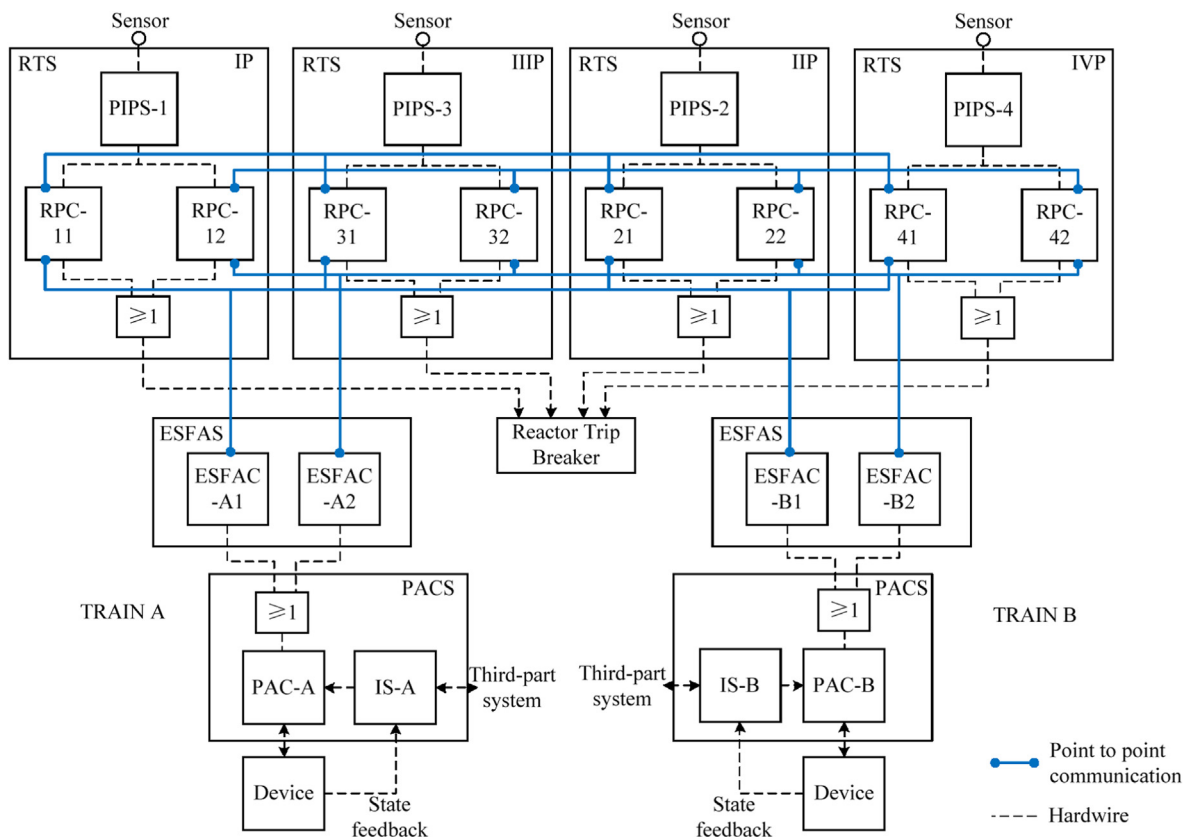

Fig. 3. Architecture of 1E DCS

is shown in Fig. 4.

The membership function of the above fuzzy number can be expressed as formula [1].

$$\mu(x) = \begin{cases} 0 & 0 \leq x \leq f - s_l - m_l \\ \frac{x - (f - s_l - m_l)}{m_l} & f - s_l - m_l < x \leq f - s_l \\ 1 & f - s_l < x \leq f + s_r \\ \frac{f + s_r + m_r - x}{m_r} & f + s_r < x \leq f + s_r + m_r \\ 0 & f + s_r + m_r < x \leq 1 \end{cases} \quad (1)$$

3.2. Failure rate analysis of T-S fuzzy fault tree

The failure rate of the components in the system can be obtained from the manufacturer or through experiments. The failure rate of the subsystem or intermediate nodes is related to the form of the system and can be calculated. Corresponding to each T-S fuzzy gate, a T-S fuzzy gate rule table is established, and each row of the table represents a fuzzy rule. The total rule number of the rule table is related to the number of T-S gate inputs and the number of failure degree states of each input. The number of input variables is represented by n , and the input variables are represented by $x_1 \dots x_n$, the output variables are expressed as $y_1 \dots y_k$. The number of fault states of variable x_i is expressed by m_i , i.e. Each state is expressed as $x_i^1, x_i^2 \dots, x_i^{m_i}$. Therefore, the total number of rules t can be expressed as

$$t = \prod_{i=1}^n m_i \quad (2)$$

Under the condition that the fault state of the component is known, the fault possibility of the superior event can be obtained according to the full probability formula, as shown in formula [3].

$$P(y_j = y_j^l) = \sum_{l=1}^t P(y_j = 1 | x_1 = x_1^l, \dots, x_n = x_n^l) P(x_1 = x_1^l) \dots P(x_n = x_n^l) \quad (3)$$

where the state of x_i in rule l is expressed as x_i^l .

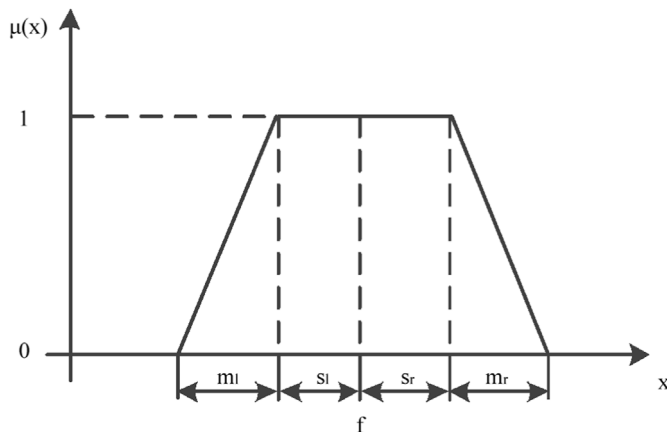

Fig. 4. Membership function for fuzzy number.

3.3. Probabilistic importance analysis based on T-S fuzzy fault tree

In the case of system failure, finding out the cause of the system failure is an important issue, which means initial component fault need to be determined. Probabilistic importance measures the effectiveness of bottom events in the respect of top event failure probability. The probabilistic importance represents the statistical comparison of the probability of failures in each part of the system, and its magnitude depends on the probability product of the other basic events in the minimum cut set and the number of repetitions in the minimum isolation. $I_q^p(x_i^j)$ represents the probabilistic importance of the failure degree x_i^j of a certain component x_i , which corresponding to a certain fault state y^q of the top event y . The calculation process is to obtain the probability of top event failure caused by a certain failure of a certain component by remaining other variables to remain unchanged, and subtract the probability of top event failure caused by a certain failure degree of the component does not failure while component fault. The formula can be expressed as:

$$I_q^p(x_i^j) = P(y^q, P(x_i^j) = 1) - P(y^q, P(x_i^j) = 0) \quad (4)$$

Then the probabilistic importance of a component x_i to the failure degree y^q of the top event y is $I_q^p(x_i)$.

$$I_q^p(x_i) = \frac{\sum_{j=1}^N I_q^p(x_i^j)}{N_i'} \quad (5)$$

In the formula, N_i' expresses the number of non-zero failure degrees of the component x_i .

4. 1E DCS reliability assessment modeling

4.1. T-S fuzzy fault tree modeling

The structure of 1E DCS is complex. For convenience of explanation, the reliability analysis is carried out by taking the output rejection of channel I (IP) of RTS as an example.

One channel of the RTS is composed of two diverse subgroups, which are in parallel relationship. The diversity is reflected in the fact that one subgroup obtains the signal with High nuclear flux – Source range and the other subgroup obtains the signal with High nuclear flux – Intermediate range. After MCU module gets the calculation result, two redundant DO modules output the calculation result of the subgroup, and further get the output result of the channel. Taking Zhangzhou nuclear power plant 1&2 units safety-class DCS as an example, which adopts the NASPIC platform developed by Nuclear Power Institute of China (NPIC). The specification of MCU is SAMC31, executing control logic. The specification of DO is SADO21, output control value to relay. The specification of relay is PLC-RSC-24DC/21-21 of Phoenix Corporation, output tripping signal.

The output rejection (y_5) of IP in 1E DCS consists of subgroup one (Gr.1) rejection (y_3) and subgroup two (Gr.2) rejection (y_4) through AND logic. y_3 is similar to y_4 . Taking y_3 as an example, it is obtained by the main controller's non-diagnosis rejection (x_1), DO rejection (y_1) and relay rejection (x_4) through OR logic. The number of DO modules is 2, the DO module 1 rejection (x_2) and the DO module 2 rejection (x_3) occur simultaneously, resulting in y_1 . The FT structure diagram is shown in Fig. 5.

According to the logic relationship of each fuzzy gate, the rule table of each fuzzy gate is formulated, and the FT model is transformed into the fuzzy FT model. In order to accurately reflect the fault state of backup loss, the FT is expressed as a T-S fuzzy FT, and

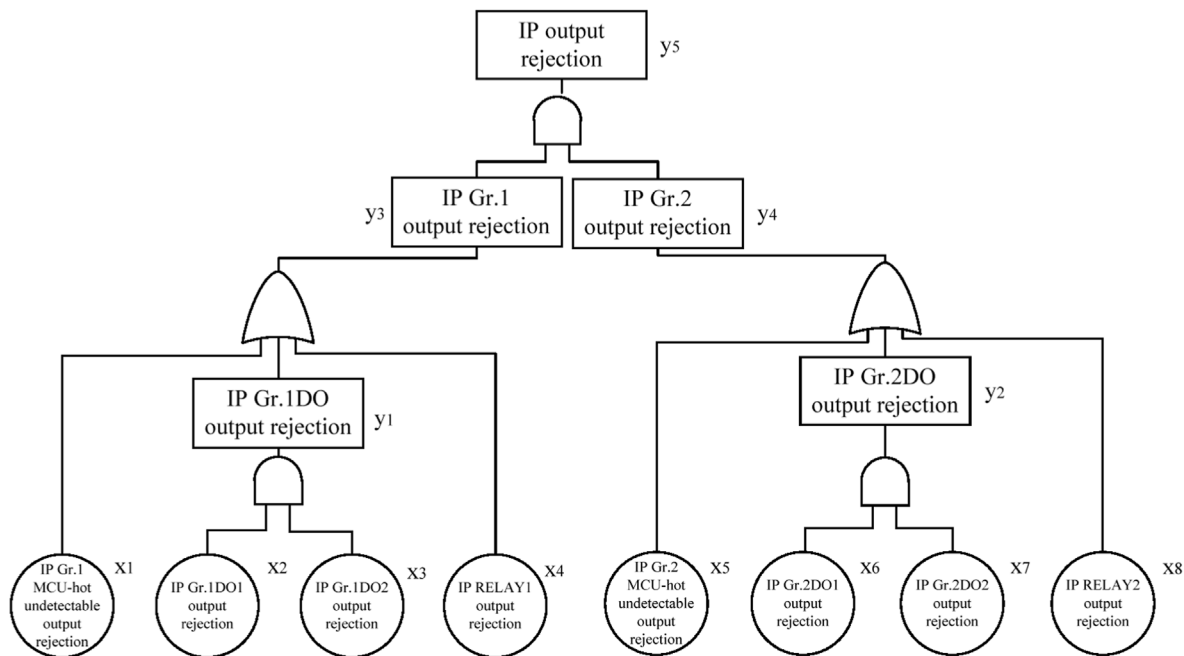

Fig. 5. Structure diagram of IP output rejection FT.

the 5 AND/OR gates of the original FT are transformed into T-S fuzzy gates to form a T-S fuzzy FT as shown in the Fig. 6.

According to empirical and experimental data, the failure degree of x_1-x_8 is divided into *no fault*, *minor fault* and *severe fault*, which are expressed by fuzzy numbers 0, 0.5 and 1, respectively. The failure degree of y_1-y_3 is divided into *no fault*, and *fault* states, which are expressed by fuzzy numbers 0 and 1, respectively. The membership function is selected as $m_l = m_r = 0.3$ and $s_l = s_r = 0.1$, and the T-S gate rule tables are obtained and shown below.

Tables 1–5 realize the fault modeling of IP output rejection of 1E DCS. In the form of T-S fuzzy gate, the relationship between

Table 1
T-S gate rules Table 1.

Rules	x_2	x_3	y_1	
			0	1
1	0	0	1	0
2	0	0.5	0.8	0.2
...
9	1	1	0	1

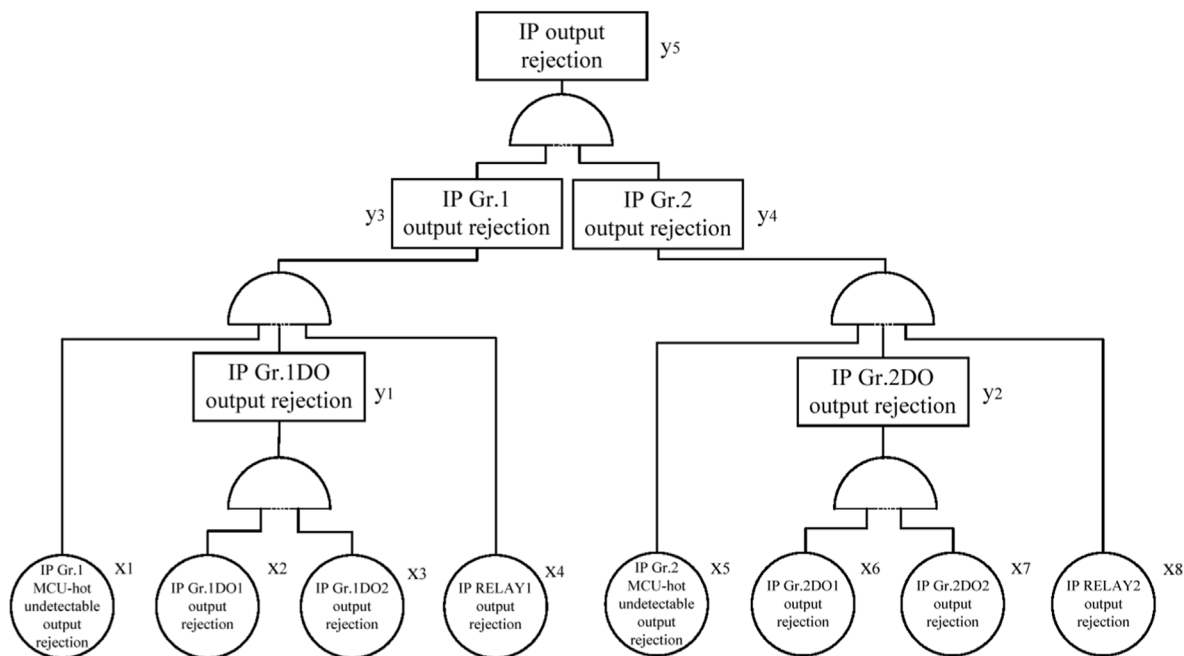

Fig. 6. Structure diagram of T-S fuzzy FT for IP output rejection.

Table 2
T-S gate rules Table 2.

Rules	x_6	x_7	y_2	
			0	1
1	0	0	1	0
2	0	0.5	0.8	0.2
...
9	1	1	0	1

Table 3
T-S gate rules Table 3.

Rules	x_1	y_1	x_4	y_3	
				0	1
1	0	0	0	1	0
2	0	0	0.5	0.9	0.1
...
18	1	1	1	0	1

Table 4
T-S gate rules Table 4.

Rules	x_5	y_2	x_8	y_4	
				0	1
1	0	0	0	1	0
2	0	0	0.5	0.9	0.1
...
18	1	1	1	0	1

Table 5
T-S gate rules Table 5.

Rules	y_3	y_4	y_5	
			0	1
1	0	0	1	0
2	0	1	0.6	0.4
3	1	0	0.6	0.4
4	1	1	0	1

components is described more specifically and comprehensively, which lays a foundation for system health analysis.

The fuzzy FT method adopted in this paper is equivalent to the FT method in model structure, so there is no problem in the structure of fuzzy FT model. The main difference between them lies in the fuzzy membership parameters and the logic gate rule table, which come from practical engineering experience. Combined with zhangzhou nuclear power plant unit 1&2 safety-class DCS in the test situation, in the process of set up the above parameters, ensure the rationality of parameter settings. Therefore, it can ensure that the fuzzy FT model not only has the rationality of structure, but also can more accurately express the logical relationship between the upper and lower levels of the system, and has the theoretical correctness.

4.2. Bayesian network equivalent modeling

The FT has advantages in the calculation from the bottom event to the top event. It can calculate the minimum cut set and is used for qualitative analysis, but it is not easy to calculate from the top event to the bottom event. In order to carry out fault diagnosis and locating from top to bottom, the T-S fuzzy FT can be equivalent transformed by BN, each T-S gate rule table can be transformed into conditional probability table of BN, and the network relationship of each node can be described. The correspondence between BN and FT logic gates is as shown in Fig. 7.

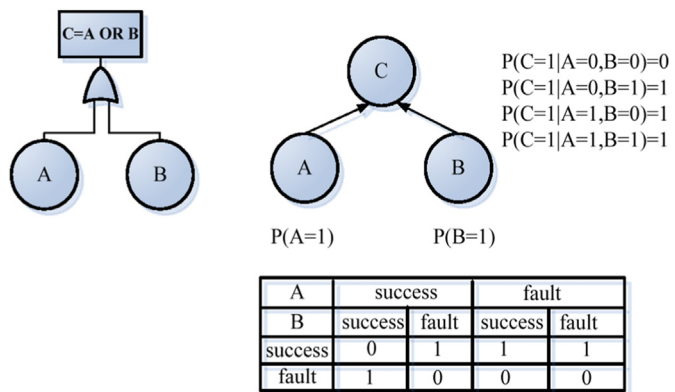

Fig. 7. Correspondence between BN and FT logic gates (OR gate as an example).

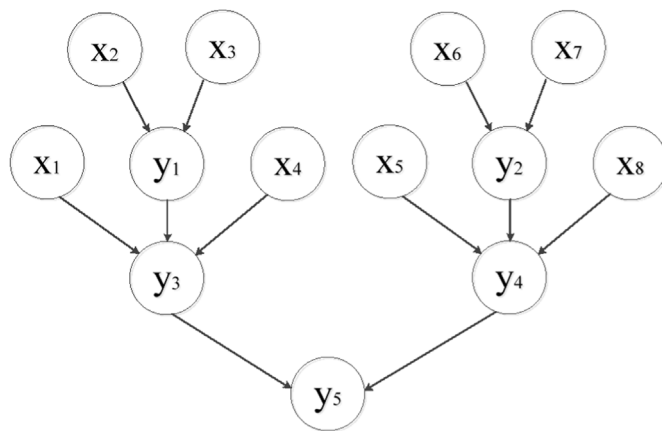

Fig. 8. BN diagram of T-S fuzzy FT transformation.

BN can clearly describe the relationship between various attributes by means of directed acyclic graphs, and express the joint probability distribution among them through conditional probability tables [23]. BN has the ability of reverse reasoning, which can solve the posterior probability of each bottom event under the assumption that the top event must occur. This capability can be used to calculate the possibility of each bottom event that causes

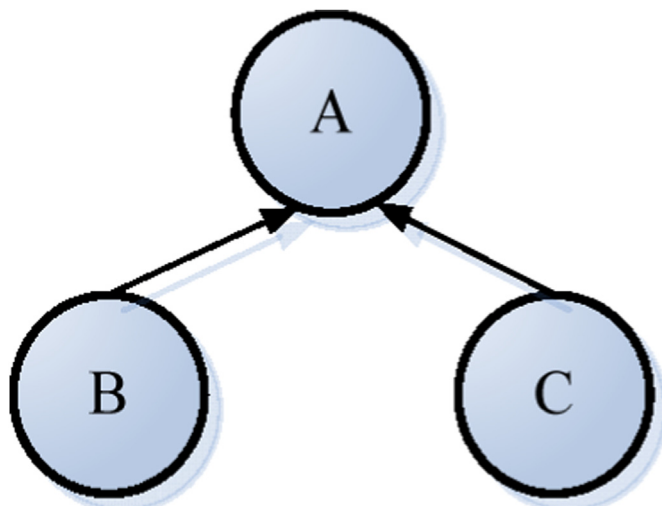
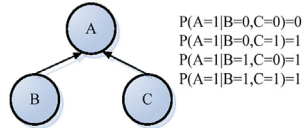

Fig. 9. Typical structure of BN diagram.

Table 6
Corresponding relationship of FT, T-S FT and BN.

Gate	And	Or																				
FT	$A = B \& C$	$A = B C$																				
	$A = \begin{cases} 0 & B = 0, C = 0 \\ 0 & B = 0, C = 1 \\ 0 & B = 1, C = 0 \\ 1 & B = 1, C = 1 \end{cases}$	$A = \begin{cases} 0 & B = 0, C = 0 \\ 1 & B = 0, C = 1 \\ 1 & B = 1, C = 0 \\ 1 & B = 1, C = 1 \end{cases}$																				
T-S FT	$\mu(x) = \begin{cases} 0 & 0 \leq x \leq f - s_l - m_l \\ \frac{x - (f - s_l - m_l)}{m_l} & f - s_l - m_l < x \leq f - s_l \\ 1 & f - s_l < x \leq f + s_r \\ \frac{f + s_r + m_r - x}{m_r} & f + s_r < x \leq f + s_r + m_r \\ 0 & f + s_r + m_r < x \leq 1 \end{cases}$																					
	Rules	B C A																				
	1	0 0 0																				
	2	0 0.5 0.8																				
																				
	9	1 1 0																				
BN																						
	<table border="1" data-bbox="375 889 646 974"> <tr> <td>B</td> <td>0</td> <td>1</td> <td>0</td> <td>1</td> </tr> <tr> <td>C</td> <td>0</td> <td>1</td> <td>0</td> <td>1</td> </tr> <tr> <td>A=0</td> <td>0</td> <td>1</td> <td>1</td> <td>1</td> </tr> <tr> <td>A=1</td> <td>1</td> <td>0</td> <td>0</td> <td>0</td> </tr> </table>	B	0	1	0	1	C	0	1	0	1	A=0	0	1	1	1	A=1	1	0	0	0	
B	0	1	0	1																		
C	0	1	0	1																		
A=0	0	1	1	1																		
A=1	1	0	0	0																		

the top event failure, and is used for fault locating and diagnosis.

The T-S fuzzy FT is transformed into a directed acyclic graph of BN. As shown in the Fig. 8, the conditional probability table of BN nodes can be obtained according to the T-S gate rule table to form BN model (see Fig. 9).

Taking the typical structure of event A formed by two modules B and C as an example, the transformation relationship of FT, T-S fuzzy FT and BN is described. The relationship between modules A, B and C is shown in the figure.

The description of FT, T-S fuzzy FT and BN methods are compared with AND and OR gates as shown in following table. T-S fuzzy FT has different transfer formulas for AND gate and OR gate. It can be understood that FT is a special case of T-S fuzzy FT, which can describe the case when the input is not 0 or 1. Then according to the expert experience, the parameters of fuzzy membership function are selected, and the T-S fuzzy gate rule table is obtained.

By transforming the rule table of each T-S fuzzy gate into conditional probability table of BN node, the T-S fuzzy FT can be equivalent transformed with BN. Each node of T-S fuzzy gate corresponds to a node of BN, and the connection relationship in the FT corresponding relationship is shown in Table 6.

Table 7
Subsystem failure fuzzy possibility.

Number	Sub-system	Failure Possibility
1	y_1	0.0666
2	y_2	0.3333
3	y_3	0.0133
4	y_4	0.2222
5	y_5	0.0948

5. Results and discussion

5.1. Fuzzy possibility calculation of system fault

According to T-S fuzzy rules, the system fault fuzzy possibility can be calculated from the fault states of each component. Assuming that the fault states of each part x_1-x_8 are 0, 0.1, 0.2, 0, 0.2, 0.8, 0.1 and 0.2, respectively, the system faults fuzzy possibility at each layer can be obtained according to the formula [3]. The subsystem failure fuzzy possibility is as shown in Table 7.

From the above calculation results, it can be seen that assuming that one DO module of Gr.2 has a serious failure, due to the redundant configuration of DO modules and the health state of the other DO module, the possibility of DO output rejection (y_2) failure of Gr.2 is low (0.3333). After combining the possibility of output rejection of the main control module with the possibility of relay output rejection, the possibility of output rejection (y_4) of Gr.2 (0.2222) is further reduced. This is accordant with the structural relationship of the actual system, which shows that the T-S fuzzy FT can be used for quantitative calculation of the fuzzy possibility of system faults.

Since the nuclear safety-class DCS modules have high performance requirements and are special customized equipment, it is usually manufactured in batches for the project before it starts. Especially for modules of same type, which are usually delivered from the same batch, their service time and failure rate are very close.

It is assumed that under certain conditions, the DO module and relay are faulty, but the MPU is not. Therefore, the failure rate of the DO module and relay is set to 0.2, and the failure rate of the MPU is set to 0. The failure rate of y_1-y_4 are 0.122, 0.122, 0.058, 0.058 according to the method described in this paper, and the occurrence probability of the top event T is 0.047.

Table 8
Sub-system failure possibility.

Sub-system	Failure rate(fit)
MCU hot 1/2 (x_1, x_5)	4.3
DO 1/2/3/4 (x_2, x_3, x_6, x_7)	3.1
Relay 1/2 (x_4, x_8)	20

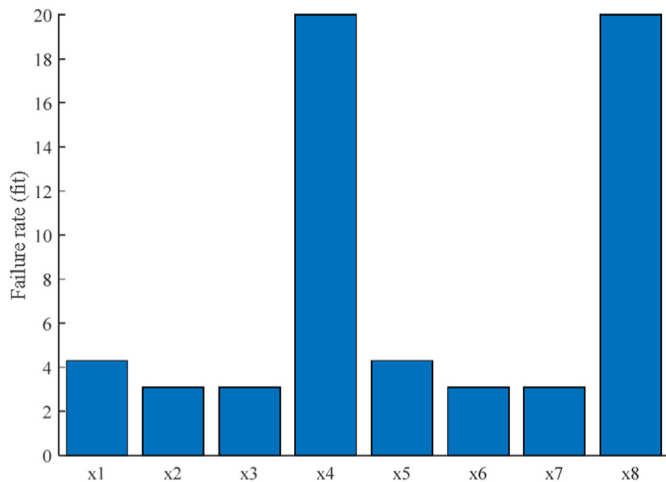

Fig. 10. Bar chart of Table 8.

Table 9
Sub-system/System failure possibility.

Sub-system/System	Failure rate(fit)
y_1/y_2	2.4800
y_3/y_4	7.786
y_5	6.230

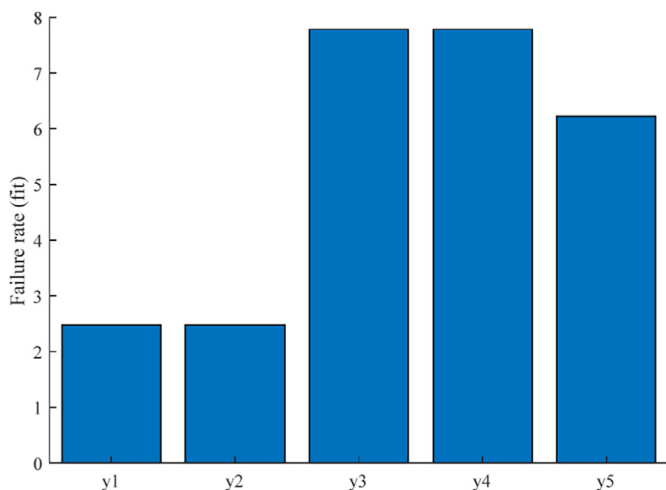

Fig. 11. Bar chart of Table 9.

5.2. Quantitative analysis of system faults fuzzy possibility based on T-S fuzzy FT

The failure rate of components can refer to the calculation method of GJB/Z299C “Electronic Equipment Reliability Prediction

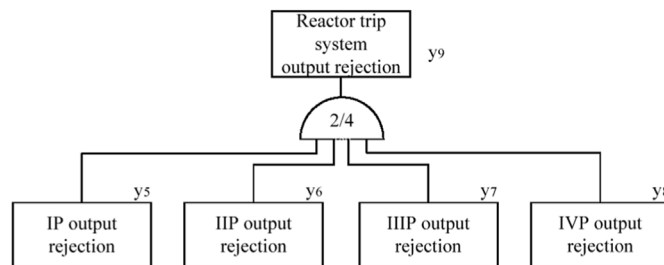

Fig. 12. System structure of reactor trip system.

Manual”, which is widely used in many fields such as aerospace and aviation. The predicted model for the operating failure rate of components such as card modules and relays is shown in the following equation.

$$\lambda_p = \lambda_b N \pi_E \pi_Q \pi_C \tag{6}$$

Where, λ_p represents the work failure rate, $10^{-6}/h$; λ_b represents the fundamental failure rate, $10^{-6}/h$; N represents the number of metallized pores of the analyzed object; π_E represents the environment factor; π_Q represents the quality factor; π_C represents the structure factor.

For the main control card element, the formula is

$$\begin{aligned} \lambda_p &= \lambda_b N \pi_E \pi_Q \pi_C = 0.000043 \times 10^{-6} \times 100 \times 1.0 \times 1.0 \times 1.0 \\ &= 0.0043 \times 10^{-6} / h \end{aligned} \tag{7}$$

Similarly, the calculation results are $0.0031 \times 10^{-6}/h$ for DO module and relays and $0.02 \times 10^{-6}/h$ respectively. After long-term operation of 1E DCS, the failure rate of various components can be verified, as shown in the following table.

The bar chart form of Table 8 is shown in Fig. 10.

Assuming that the failure rate keeps the same while state is 1 and 0.5, the failure rate of each subsystem or top event can be calculated, and the results are shown in Table 9.

The bar chart form of Table 9 is shown in Fig. 11.

Through qualitative calculation, verification and analysis, the probability of system-level faults and component-level faults is in the same order of magnitude, and based on the redundant structure, the failure rate of top event (y_5) is relatively low, which is consistent with the actual situation. In the system architecture, the component with the highest failure rate is relay (x_4/x_8). The failure rate of system top event y_5 is much lower than that of relay, which is also consistent with the actual state of affairs. The failure rate of sub-event Gr.1 DO rejection (y_1) is lower than that of a single DO module, which verifies the effectiveness of redundancy structure in reducing system failure risk.

The four protection channels adopt 2 out of 4 logic, constituting the output logic of the total reactor protection system. Combine with the calculation of a single channel, the calculation result of the system rejection rate can be obtained. System construction of reactor trip system is shown as Fig. 12.

The 4 protection channels have the same structure, and the probability of reactor protection system output (y_9) can be calculated from the failure rate (6.23Fit) of y_5 according to the 2 out of 4 logic. At the 200th hour, the probability of y_9 is 0.0006956; at the 1000th hour, the probability of y_9 is 0.0156089; and at 1st year, the probability of y_9 is 0.455995.

Table 10
 x_1/x_5 conditional probability table.

Conditional probability	Value
$P(y_5 = 1, x_1 = 0)$	0.0984
$P(y_5 = 1, x_1 = 0.5)$	0.1600
$P(y_5 = 1, x_1 = 1)$	0.2014

Table 11
 $x_2/x_3/x_6/x_7$ conditional probability table.

Conditional probability	Value
$P(y_5 = 1, x_2 = 0)$	0.0984
$P(y_5 = 1, x_2 = 0.5)$	0.1020
$P(y_5 = 1, x_2 = 1)$	0.1348

Table 12
 x_4/x_8 conditional probability table.

Conditional probability	Value
$P(y_5 = 1, x_4 = 0)$	0.0984
$P(y_5 = 1, x_4 = 0.5)$	0.1524
$P(y_5 = 1, x_4 = 1)$	0.1355

Table 13
 Calculation results of probabilistic importance of each component.

Component	Probabilistic importance	
	$I_1^{0.5}(x_i)$	$I_1^1(x_i)$
x_1/x_5	0.0652	0.1066
$x_2/x_3/x_6/x_7$	0.0072	0.040
x_4/x_8	0.0407	0.0875

Table 14
 BN conditional probability table (y_1).

x_2	x_3	$P(y_1)$
0	0	1
0	0.5	0.8
...
1	1	0

5.3. Importance analysis based on T-S fuzzy fault tree

As mentioned above, the probabilistic importance can characterize the probability of failure of each component in the respect of statistic, and indicates that the magnitude of the failure rate changes of the system caused by the change of the underlying component from the normal state to the failure state [24]. According to the system architecture corresponding to the one channel (IP)output rejection in 1E DCS RTS, the conditional probability of each failure degree of each underlying component affecting the top event is solved. As shown in Tables 10–12.

Therefore, the probabilistic importance of each component is shown in Table 13.

Table 15
 Sub-event failure probability.

Component	x_1	x_2	x_3	x_4	x_5	x_6	x_7	x_8
Status 0	0.9863	0.9821	0.5511	0.9859	0.5871	0	0.9834	0.6909
Status 0.5	0.0074	0.0071	0.4487	0.0079	0.4128	0.2626	0.0071	0.3090
State 1	0.0062	0.0108	0.0002	0.0063	0.0001	0.7374	0.0096	0.0002

It has been seen from the importance analysis that x_1 and x_5 have the highest importance, which correspond to MPU and are the most important in the system. The key part confirms the rationality of calculation. At the same time, 1E DCS has adopted hot-standby redundancy for the MPU to improve the reliability of the system. This analysis is also replicated in terms of conditional probability, when MPU state declines, the system health status decreases more obviously. In terms of project implementation, MPU spare modules should be prepared to decrease the impact of the equipment failure on the system.

5.4. Fault diagnosis based on Bayesian network

Taking y_1 as an example, the conditional probability table of BN is established, as shown in Table 14.

The process of establishing BN conditional probability table for other events is similar. Assuming system top event (y_5) fault, the possibility of each component under various fault states is obtained by using the reverse reasoning ability of BN. The calculation results are shown in Table 15.

According to the calculation results, it can be seen that in the case of y_5 failure, x_6 has the greatest possibility of failure (0.7374), indicating that in this case, the bottom event most likely to cause system failure is x_6 (the second DO module in Gr.2 output rejection). According to the current fault situation of various components, x_6 has the most serious fault, which is consistent with the reverse analysis results of BN. The above experiments prove that the BN transformed from T-S fuzzy FT can be used for fault diagnosis.

6. Conclusion

Based on T-S fuzzy FT and BN, the reliability analysis of 1E DCS can be effectively carried out. 1E DCS adopts a large number of redundant designs, and the traditional FT cannot describe sub-health states such as backup loss. T-S fuzzy FT can be used to quantitatively describe the reliability of 1E DCS. Taking probabilistic importance as indicators, the short board of system failure is analyzed. The T-S fuzzy FT is transformed into BN, and by applied the posterior calculation of BN, fault locating and diagnosis can be realized. Taking a sub-system of 1E DCS as an example, the experimental results are verified, which proves that the method is suitable for reliability analysis of 1E DCS and feasible in engineering practical.

The test method adopted in this paper is simulation test. In the future work, the fault data of DCS modules can be counted in real time to verify the model. In the process of collecting data, it is planned to obtain at least half a year of continuous module reliability data from Zhangzhou nuclear power plant 1&2 units safety-class DCS in test stage, the range includes analog input module, analog output module, digital input module and DO module. Taking the NASPIC platform developed by NPIC as an example, the collected module models include SAAI21, SAAO31, SADI21, SADO21 et al., and data types include module fault data and system self-diagnosis variable data, which are imported into the database software to obtain the input of Bayesian model in the manuscript.

For the module with a low failure rate, data can be obtained from the module component manufacturer or from the same batch of products to further verify the correctness of the model in the real scenario.

Funding

The project was funded by Sichuan Provincial Youth Science and Technology Fund (2020JDJQ0068).

Declaration of competing interest

The authors declare that they have no known competing financial interests or personal relationships that could have appeared to influence the work reported in this paper.

References

- [1] B. Geddes, R. Torok, Digital I&C operating experience in the US, *Trans. Am. Nucl. Soc.* 98 (1) (2008) 299–302.
- [2] Renpeng Liu, Xiaozhou Ye, Yang Liu, Reliability analysis of auxiliary water supply system based on dynamic fault tree, *Appl. Electron. Technol.* 115 (2021) 177–184.
- [3] Mohan Rao Mamdakar, Vinay Kumar, Pooja Singh, Dynamic reliability analysis framework using fault tree and dynamic Bayesian network: a case study of NPP, *Nucl. Eng. Technol.* 54 (2022) 1213–1220.
- [4] Haoyang Pan, Continuous Time T-S Multidimensional Dynamic Fault Tree Analysis Method and Hydraulic Reliability Application, 2019.
- [5] Feng Zhang, Shiwang Tan, Leilei Zhang, et al., fault tree interval analysis of complex systems based on universal grey operation, *Complexity* (2019) 1–8, 2019.
- [6] H. Pan, W. Yun, Fault tree analysis with fuzzy gates, *Comput. Ind. Eng.* 33 (3) (1997) 569–572.
- [7] C.T. Lin, M.J. Wang, Hybrid Fault tree analysis using fuzzy sets, *Reliab. Eng. Syst. Saf.* 58 (3) (1997) 205–213.
- [8] Hua Song, Hongyue Zhang, Xingren Wang, Fuzzy fault tree analysis based on T-S model, *Control Decis.* 20 (8) (2005) 854–858.
- [9] Chen Wu, Guohua Zhang, Hao Wang, et al., Evaluation of probability of tunnel collapse by drilling and blasting method based on T-S fuzzy fault tree, *Rock Soil Mech.* 40 (S1) (2019) 319–328.
- [10] Dongning Chen, Chengyu Yao, Zhen Dang, Reliability analysis of multi-state hydraulic system based on T-S fuzzy tree and Bayesian network, *China Mech. Eng.* (7) (2013) 899–905.
- [11] Dongning Chen, Chengyu Yao, Reliability analysis of multi-state system based on fuzzy Bayesian networks and application in hydraulic system, *J. Mech. Eng.* 48 (16) (2012) 175–183.
- [12] Lina Sun, Huang Ning, Weiqiang Wu, Etc. Performance reliability of polymorphic systems based on T-S simulation fault tree, *J. Mech. Eng.* 52 (10) (2016) 191–198.
- [13] Le Chen, Xianlin Wang, Weifei Li, et al., The reliability analysis of Turret system based on T-S fuzzy fault tree, *Modul. Mach. Tool Autom. Manuf. Technol.* 2 (2019) 143–146.
- [14] Chengyu Yao, Dongning Chen, Bin Wang, Fuzzy reliability assessment method based on T-S fault tree and Bayesian network, *J. Mech. Eng.* 50 (2) (2014) 193–201.
- [15] Chengyu Yao, Yingyi Zhang, Dongning Chen, et al., Research on T-S fuzzy import analysis methods, *J. Mech. Eng.* 47 (12) (2011) 163–169.
- [16] S.M. Lavasani, A. Zendegani, M. Celik, An extension to fuzzy fault tree analysis (FFTA) application in petrochemical process industry, *Process Saf. Environ. Protect.* 93 (2015) 75–88.
- [17] Y.E. Senol, Y.V. Aydogdu, B. Sahin, et al., Fault tree analysis of chemical cargo tamination by using fuzzy approach, *Expert Syst. Appl.* 42 (12) (2015) 5232–5244.
- [18] Huadong Ding, Huahu Xu, Ran Duan, et al., Network security situation awareness model based on Bayesian method, *Comput. Eng.* 46 (6) (2020) 130–135.
- [19] Dongning Chen, Jing Zhang, Chengyu Yao, et al., Dynamic fault tree analysis of hydraulic heightening system based on DTBN, *Mach. Tool Hydraul.* 49 (13) (2021) 183–189.
- [20] P. Kumar, L.K. Singh, C. Kumar, Performance evaluation of safety-critical systems of nuclear power plant systems, *Nucl. Eng. Technol.* 52 (3) (2020) 560–567.
- [21] E.C. Lee, S.K. Shin, P.H. Seong, Evaluation of availability of nuclear power plant dynamic systems using extended dynamic reliability graph with general gates (DRGGG), *Nucl. Eng. Technol.* 51 (2) (2019) 444–452.
- [22] H.A. Gohel, H. Upadhyay, L. Lagos, et al., Predictive maintenance architecture development for nuclear infrastructure using machine learning, *Nucl. Eng. Technol.* 52 (7) (2020) 1436–1442.
- [23] Zhihua Zhou, Machine Learning, Tsinghua University Press, Beijing, 2016.
- [24] Zhihong Xiong, Jun Liu, Bin Fan, et al., Research on fuzzy fault tree analysis method for hydraulic cylinder based on T-S model, *J. Hunan City Univ. (Nat. Sci.)* 26 (4) (2017) 47–51.