

# Enhancement in Isolation among Collinearly Placed Microstrip Patch Antenna Arrays

Irfan Ali Tunio<sup>\*\*1</sup>, Hernan Dellamaggiora<sup>††1</sup>, Umair Saeed<sup>†2</sup>, Ayaz Ahmed Hoshu<sup>†3</sup>, Ghulam Hussain<sup>†4</sup>

[enr.irfan.ali@quest.edu.pk](mailto:enr.irfan.ali@quest.edu.pk) [hernan.dellamaggiora@gmail.com](mailto:hernan.dellamaggiora@gmail.com) [umair.saeed25@quest.edu.pk](mailto:umair.saeed25@quest.edu.pk)

[ayaz.soomro@quest.edu.pk](mailto:ayaz.soomro@quest.edu.pk) [enr.ghulam.hussain@quest.edu.pk](mailto:enr.ghulam.hussain@quest.edu.pk)

<sup>†</sup>Quaid-e-Awam University of Engineering, Science & Technology Campus Larkana, 77150, Pakistan

<sup>††</sup>University of Nantes, 44035, France

## Summary

Strong surface waves among collinearly arranged patch antenna arrays pose unwanted inter element coupling particularly when high permittivity dielectric materials are used. In order to avert those waves, a novel Defected Ground Structure (DGS) is carved out systematically between two E-plane patch antenna elements. The introduced low profile  $\mu$  shaped structure consequently improves impedance bandwidth and reflection coefficient by suppressing surface waves considerably. Parametric simulation results are analyzed and discussed.

## Keywords:

Antenna array, mutual coupling, patch antenna, defected ground structure, surface waves, return loss, impedance bandwidth.

## 1. Introduction

Nowadays, it has become quite common to utilize multiple antennas in wireless systems as a single device. Among such systems mutual coupling stands out to be an unwanted phenomenon in most cases. Mutual coupling effect can be described as the electric field generated by an antenna that produces or alters current distribution of the other elements placed in its vicinity leading to distortions in the radiation pattern as compared to their isolated patterns.

To achieve independence of the signals that are received or transmitted from the antennas, the coupling between them have to be removed or at least reduced. For this reason, different methods to reduce coupling between array elements have been studied and developed.

Printed class of antenna arrays has, however, attracted popularity due to their multifarious advantages. Microstrip antenna arrays are one of outstanding class of such printed antennas. A basic printed microstrip antenna consists of three layers: ground plane, substrate and the patch. The coupling mechanism that exists in such microstrip patch antenna arrays may be mainly of three types: surface waves, near field and space waves coupling [1]. Depending on many factors like substrate material thickness, ground plane, and type of modes that are excited by the patch antenna, one of the coupling

mechanisms mentioned may dominate over the others.

However, the domination of surface wave coupling occurs when the patch antennas are printed on high permittivity dielectric substrates and becomes more dominant when the thickness of the substrate increases in accordance with condition (1);

$$\text{Substrate thickness} \geq \frac{0.3\lambda_0}{(2\pi/\sqrt{\epsilon_r})} \quad (1)$$

where  $\lambda_0$  is the wavelength in free space and  $\epsilon_r$  is the relative permittivity of substrate [2]. These surface waves travel inside the dielectric substrate and when they reach the ground plane edges, they diffract and propagate (Fig.1).

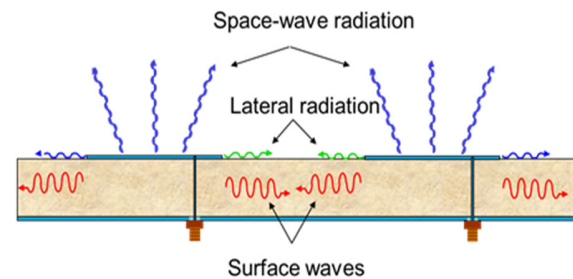

Fig. 1: Mutual coupling mechanism in patch antennas.

Different methods have been proposed to reduce mutual coupling due to such surface waves in microstrip patch antennas. Some of them are based on optimizing the antenna design, adding dielectric layers to cover the patch, scratching the dielectric material, inserting shorting pins at the substrate to cancel polarization currents, usage of meta materials called wave absorbers that cause magnetic resonance and a band gap that improve the insulation between the patch elements, using dielectric structures as band gaps between antenna elements called electromagnetic bandgap (EBG) structures, or using the

techniques called defected ground structure (DGS) which is basically a technique to carve out some shapes (Symmetrical or asymmetrical) in the ground plane in between antenna elements in order to alter the course of surface waves and change the effective dielectric constant of the substrate (changing its capacitance and inductance) which produce a frequency band elimination effect with similar characteristics to EBG structures but of simpler manufacturing and also requires less surface to implement [3],[4],[5],[6]. Due to this fact of band rejection characteristic and ease of implementation, the DGS technique has been used in a wide number of microwave circuits and antenna array design applications [7],[8].

In this paper, an etched DGS (we call it  $\mu$  for its similarity to the Greek letter  $\mu$ ) is introduced to increase isolation between two E-plane patch antenna array elements. This novel structure not only reduces mutual coupling (transmission coefficient) but also improves return loss of the antennas.

In section 2, we simulate two patch antenna elements (without and with DGS) arranged collinearly (E- plane) and show their S parameters. In Section 3, conclusion and future work is outlined.

## 2. 3D Simulation

### 2.1 Patch antenna array without DGS

Firstly, we design and optimize a single patch antenna for a desired frequency and then we put it in an array arrangement. Keeping in view the manufacturing, testing and analyzing capabilities of our laboratory, we have chosen our antenna design for a resonant frequency of 5GHz. Growing demand of WiFi for speed is another motivating factor behind opting for this frequency [9]. Table 1 shows the optimized parameters of a patch antenna structure.

**Table 1:** Patch antenna design parametric values.

Description	Values
Targeted Frequency	5 GHz
Patch and ground material	copper ( 35 $\mu$ m Thick)
Patch antenna length	13.185 mm
Patch antenna width	17.38 mm
Substrate material	FR4 epoxy ( $\epsilon_r = 4.4, \tan \delta = 0.02$ )
Height of the Substrate	1.6 mm
Substrate and ground length	73.13 mm
Substrate and ground width	77.38 mm
Antenna feed	Coaxial feed

The antenna has been simulated in ANSYS HFSS 2017 (Fig. 2). The S parameters of the antenna show a good matching at 5GHz with return loss ( $S_{11}$ ) of -35dB (Fig. 3).

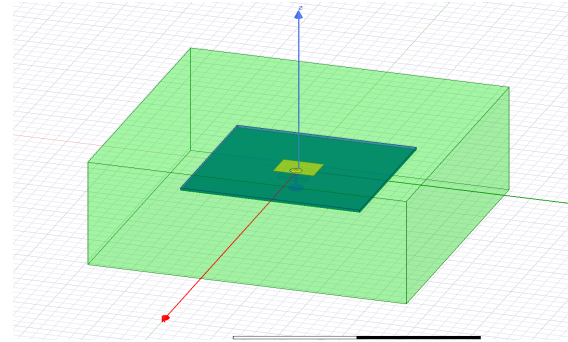

**Fig. 2:** 3D simulation of a single optimized patch antenna.

After optimization single antenna element now we can insert another antenna without any decoupling method so that later on it can be compared with that of DGS. Both radiating elements are collinearly arranged along the E-plane at a distance of  $0.4\lambda_0$  (Fig. 4).

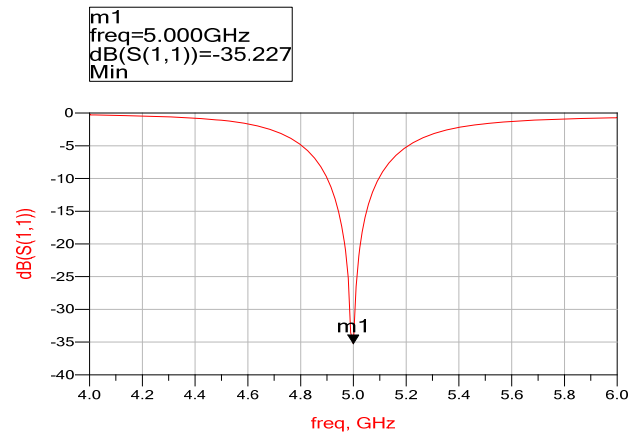

**Fig. 3:** Reflection coefficient of an optimized patch antenna.

The array is simulated and its corresponding S parameters are shown in Fig. 5. The conventional antennas show a mutual coupling ( $S_{12}$ -21) of approximately -17.78 dB mainly due to the presence of surface waves within the substrate (Condition 1). An impedance bandwidth ( $|S_{11} \& S_{22}| < 10$  dB) of approximately ~200 MHz is observed. It can be seen that both antennas exhibit almost -34 dB return loss at the resonant frequency. Despite having same parameters of both antennas, one of the antennas resonates around 4.99GHz which is a slight variation and this may have resulted due to the introduced mesh on the antennas.

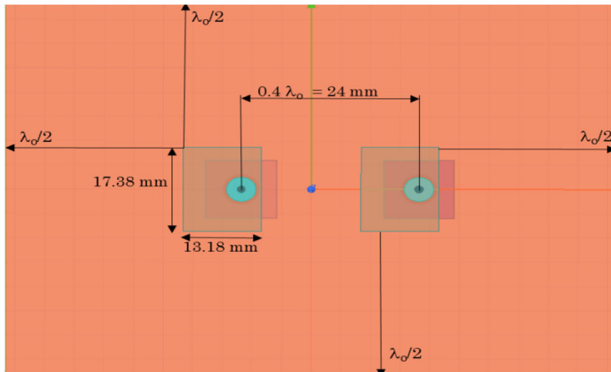

Fig. 4: Array of two co-linearly arranged patch antenna elements without DGS.

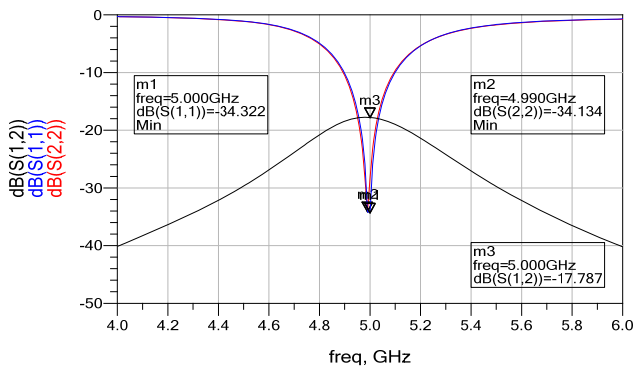

Fig. 5: Simulated S parameters without DGS.

### 2.2 Patch antenna array with $\mu$ -shape DGS

In order to suppress the strong surface waves a defected ground structure is introduced between the adjacent E-plane coupled elements in the array. The DGS proposed in this work is based on rectangular slots, forming a  $\mu$ -shape and its image, as shown in the Fig. 6(a). The structure is centered between two antenna elements and optimized in dimensions, relative position and relative distance to reduce the mutual coupling on a desired frequency band Fig. 6(b).

The optimization process is carried out on the proposed design. The optimized parameters for the DGS are;

$L1 = 11.5mm$ ,  $L2 = 10mm$ ,  $L3 = 5.7mm$ ,  $L4 = 5.3mm$ ,  $W1 = 3.5925mm$ ,  $D1 = 0.2mm$ ,  $D2 = 1mm$ ,  $D3 = D4 = 0.5mm$ . The total etched area is  $= 36.8 mm^2$  ( $2 \times 18.4mm^2$ ).

As expressed in the theoretical approach, surface waves can be associated to the surface current distribution in the ground plane of the antenna elements [10]. The simulated surface current distribution on the common ground plane for the cases (with and without the proposed DGS slots) are presented in Fig.(7 & 8) at  $90^\circ$  phase. It can be observed from Fig.8 that some part of the surface

current generated by one antenna circulate around the slots and affect less the second antenna than in the case without slots where surface currents easily gets coupled by the adjacent antenna (Fig. 7). The slots prevent part of the fields from crossing to the other element, which decrease the mutual coupling between array elements.

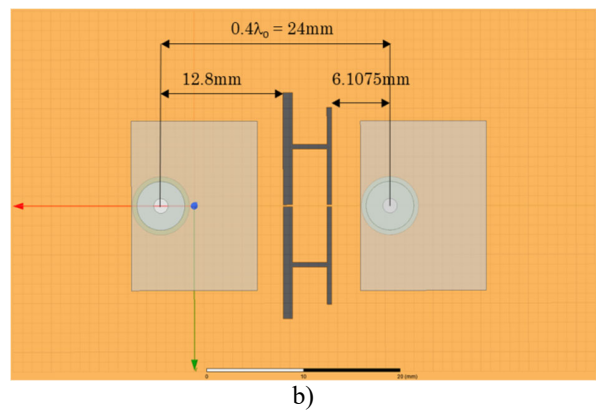
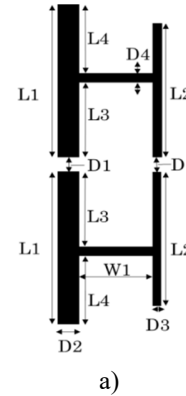

Fig. 6: a) Proposed DGS design structure, b) Array of two collinearly arranged patch antenna elements with carved  $\mu$  shaped DGS

As expressed in the theoretical approach, surface waves can be associated to the surface current distribution in the ground plane of the antenna elements [10]. The simulated surface current distribution on the common ground plane for the cases (with and without the proposed DGS slots) are presented in Fig.(7 & 8) at  $90^\circ$  phase. It can be observed from Fig.8 that some part of the surface current generated by one antenna circulate around the slots and affect less the second antenna than in the case without slots where surface currents easily gets coupled by the adjacent antenna (Fig. 7). The slots prevent part of the fields from crossing to the other element, which decrease the mutual coupling between array elements.

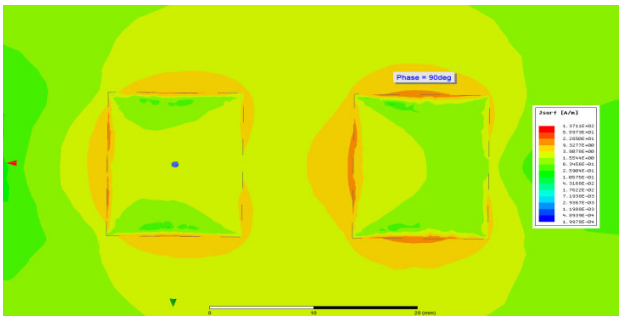

Fig. 7: A screen shot of Surface current distribution without DGS at 90° phase during animation.

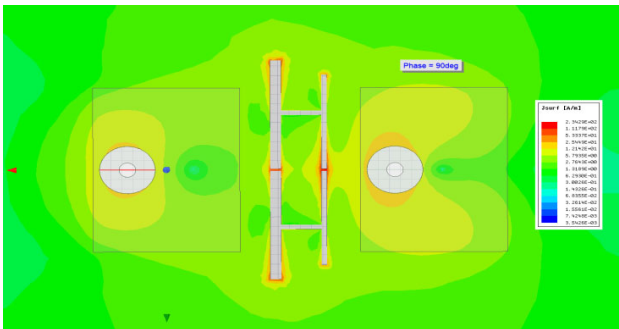

Fig. 8: A screen shot of Surface current distribution with DGS at 90° phase during animation.

Scattering parameters of the decoupled antenna array show -33.4 dB amount of mutual coupling which is about 16 dB lower than the conventional antenna array (Fig.9). Here, the filtering slots with the proper position and dimensions exhibit rejection band at 5.07 GHz. This frequency shift may have been caused by the slow wave effect of the DGS. The DGS presents a bandstop effect because of the combination of equivalent inductance and capacitance, which depends on several parameters: length ( $L_x$ ), width ( $W_x$ ), spacing & thickness of slots ( $D_x$ ) and the relative position in the array. Also, it can be observed that the antennas exhibit better return loss response in DGS with an impedance bandwidth (~300MHz) which is slightly over than the conventional antenna array at the rejection band.

It is also observed that when  $L1$  and  $L2$  have unequal lengths, a satisfactory isolation within the matching bandwidth can be achieved. There is an important relationship between the ratio  $L1/L2$  and the rejected bandwidth in this design. The rejected bandwidth is also sensitive to the width of the slots ( $W1$ ), which in this design is proportional to the resonance frequency of the rejection band. Other crucial parameter, in this design, is the position of the slots. The most appropriate position is in the middle of the ground plane.

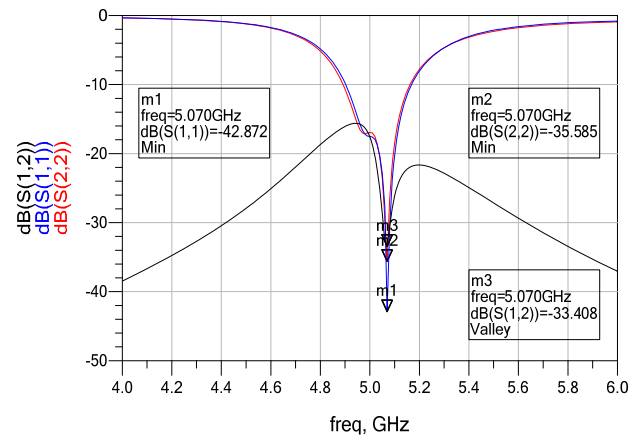

Fig. 9: Simulated S parameters with DGS.

A parametric analysis of the variation of the cutoff frequency in terms of different dimensions of the slots was carried out. It was found that a variation in width ( $W1$  in our design, Fig. 6(a)) produces a linear shift in the cutoff frequency for this particular design. As the width of DGS is reduced and increased, a tendency of a higher and lower cut off frequency is observed respectively. S Parametric analysis of mutual coupling cutoff frequency shift with respect to width of DGS is illustrated in Fig. 10.

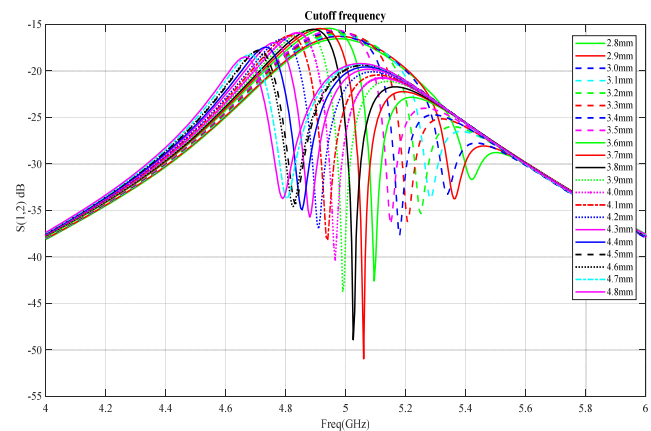

Fig. 10: Mutual coupling cutoff frequency shift with respect to the width ( $W1$ ) of the DGS.

### 3. Conclusion

A novel compact Defected Ground Structure has been introduced to enhance isolation between two E plane patch antenna elements. The simulations show that after introducing DGS, the isolation between antenna elements improves resulting in better return loss and impedance bandwidth. This antenna array can be a good choice for WiFi speed related projects.

## References

- [1] C. A. Balanis, *Antenna Theory: Analysis and Design*, 3rd ed., vol. 38, no. 6. John Wiley & Sons, 2005.
- [2] A. R. Djordjevic and M. M. Nikolic, "Microstrip Antennas With Suppressed Radiation in Horizontal Directions and Reduced Coupling," *IEEE Trans on Antennas and Propagation*, vol. 53, no. 11, pp. 3469–3476, 2005.
- [3] I. Nadeem and D. Choi, "Study on Mutual Coupling Reduction Technique for MIMO Antennas," *IEEE Access*, vol. 7, pp. 563–586, 2019.
- [4] D. Guha, S. Biswas, and C. Kumar, "Printed antenna design using defected ground structures: a review of fundamentals and state-of-the-art developments," in *Proceedings of the Forum for Electromagnetic Research Methods and Application Technologies (FERMAT '14)*, vol. 2, pp. 1–13, April 2014.
- [5] X. Tan, W. Wang, Y. Wu, Y. Liu and A. A. Kishk, "Enhancing Isolation in Dual-Band Meander-Line Multiple Antenna by Employing Split EBG Structure," in *IEEE Transactions on Antennas and Propagation*, vol. 67, no. 4, pp. 2769-2774, April 2019.
- [6] Bahare Mohamadzade, Ali Lalbakhsh, Roy B. V. B. Simorangkir, Alireza Rezaee, and Raheel M. Hashmi, "Mutual Coupling Reduction in Microstrip Array Antenna by Employing Cut Side Patches and EBG Structures," *Progress In Electromagnetics Research M*, Vol. 89, 179-187, 2020.
- [7] Amandeep Kaur and Praveen Kumar Malik, "Multiband Elliptical Patch Fractal and Defected Ground Structures Microstrip Patch Antenna for Wireless Applications," *Progress In Electromagnetics Research B*, Vol. 91, 157-173, 2021.
- [8] Gupta, N., Bhardwaj, P. & Balhara, S. Designing of "Defected Ground Structure Patch Antenna for Vehicular Safety Applications at 5.9 GHz," *Wireless Personal Communications* 121, 95–106, 2021.
- [9] Irfan Ali Tunio, Yann Mahe, Tchanguiz Razban-Haghighi and Bruno Froppier, "Mutual Coupling Reduction in Patch Antenna Array Using Combination of Shorting Pins and Metallic Walls," *Progress In Electromagnetics Research C*, Vol. 107, 157-171, 2021
- [10] Y. Xu, Z. Peng, S. Wen and Y. Dong, "Omnidirectional Circularly Polarized Antenna Array With Planar Configuration," in *IEEE Transactions on Antennas and Propagation*, vol. 70, no. 9, pp. 8602-8607, Sept. 2022.