

# A Survey of Machine Translation and Parts of Speech Tagging for Indian Languages

Vijayshri Khedkar<sup>1†</sup>, Pritesh Shah<sup>2</sup>

[vijayshri.khedkar@sitpune.edu.in](mailto:vijayshri.khedkar@sitpune.edu.in), [pritesh.shah@sitpune.edu.in](mailto:pritesh.shah@sitpune.edu.in)

<sup>1</sup>Research Scholar, Symbiosis Institute of Technology, Symbiosis International (Deemed University), Pune, India

<sup>2</sup> Symbiosis Institute of Technology, Symbiosis International (Deemed University), Pune, India

## Summary

Commenced in 1954 by IBM, machine translation has expanded immensely, particularly in this period. Machine translation can be broken into seven main steps namely- token generation, analyzing morphology, lexeme, tagging Part of Speech, chunking, parsing, and disambiguation in words. Morphological analysis plays a major role when translating Indian languages to develop accurate parts of speech taggers and word sense. The paper presents various machine translation methods used by different researchers for Indian languages along with their performance and drawbacks. Further, the paper concentrates on parts of speech (POS) tagging in Marathi dialect using various methods such as rule-based tagging, unigram, bigram, and more. After careful study, it is concluded that for machine translation, parts of speech tagging is a major step. Also, for the Marathi language, the Hidden Markov Model gives the best results for parts of speech tagging with an accuracy of 93% which can be further improved according to the dataset.

## Keywords:

Machine translation, HMM, Marathi language translation.

## 1. Introduction

George Bernard Shaw once quoted, “The single biggest problem in communication is the illusion that it has taken place”. How do we know that what we said, what we wrote, was understood by all? There are around 6500 languages around the world out of which about 2000 languages have less than 1000 existing speakers. With such numbers, globalization became a colossal challenge. This is where machine translation comes into the picture. It can assist businesses in many ways and can also replace human beings in many applications. IBM came up with the concept of Watson Language Translator [1] in 1954 at its headquarters in New York. Machine translations play a major role when connecting two different businesses of divergent scopes or two different people speaking two distinct languages. Machine translation [2] process can be widely divided into main seven terms [3] as mentioned below:

- Tokenization- It is the task of chopping a sentence into pieces known as tokens

- Morphological Analysis- It is the procedure of supplying grammatical instructions about the word based on properties of the morpheme it contains.
- Lexeme- It is the smallest unit of meaning in the vocabulary of a language.
- POS tagging- It is the task of transforming a sentence to a catalogue of words and a catalogue of tuples where each tuple has the form (word, tag).
- Chunking- It is a process of meaningful uprooting of short phrases from the sentence.
- Parsing- It is the procedure of recognizing the syntactic structure of a text by inspecting its constituent words based on a well-defined grammar.
- Word sense disambiguation- It is the task of deciding which signification of a word is triggered by the use of the word in a specific situation.

According to an analysis by Scopus in recent years' machine translation has become a very famous and researched topic. Figure 1 depicts the amount of research done on machine translation in recent years.

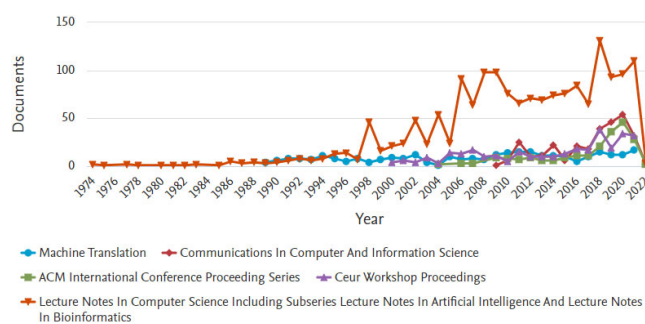

Figure 1. Distribution of research in machine translation by year

The studies done on Scopus show that United States and China are the leading countries in machine translation research followed by the India and Japan. See figure 2 for research by different countries.

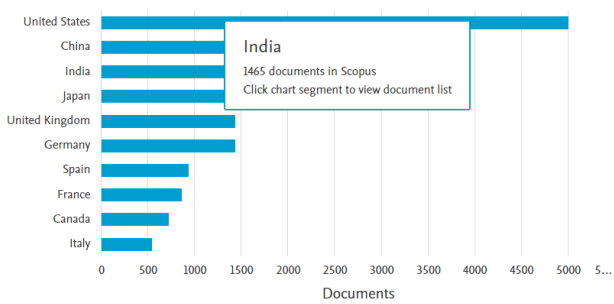

Figure 2. Country-wise distribution of research in machine translation

India is a multilingual country. It has a total of 22 official languages with over 2000 dialects. The Indian government also plans to give more thrust to machine translation in the upcoming term. Our research was mainly based on translations of Indian languages. The aim was to look out for ways in which we can contribute to help the part of society that faces continuous issues while connecting to this fast-moving globalized world.

Duncan MacDonald once said, “The common facts of today are the products of yesterday’s research”. What's new today

would be gospel tomorrow. Different researchers have used different techniques and these techniques have evolved with time. Table I depicts a timeline chart for machine translation at international level [34], [35], [36].

For Indian languages such as Marathi, Gujarati, Punjabi, Tamil, etc, it is important to concentrate on the morphological structure of the language to develop accurate parts of speech tagger and word sense. Different researchers have used different machine translation methods and recorded their results with advantages and disadvantages as discussed further in the paper. Till now Bengali, Urdu, Gujarati, Punjabi, Tamil, Malayalam, Telugu, and Urdu are the main Indian languages on which translation has been implemented as stated by Mr. Nadeem Jadoon Khan, Mr. Waqas Anwar and Mr. Nadir Durrani of COMSAT University and University of Edinburgh [4].

The first step towards translation in any language is identifying and classifying the parts of our sentences [5]. Part of Speech tags is useful for constructing parse trees, which are used in creating NERs [6] and extracting relations between words. POS Tagging also finds its use in building lemmatizes which are used to reduce a word to its root form.

Table 1. History of Machine Translation

Period		Activity
1948- 1960	The Beginning	Warren Weaver first proposed the term Machine Translation and the first symposium related to it was held at MIT. Later IBM made the first translator in 1954.
1960- 1966	Parsing and enlightenment	The first International conference related to MT was held mainly on the linguistics developed by Rand Corporation in Los Angeles. In 1964, ALPAC (Automatic Language Processing Advisory Committee) was formed which published its first research in 1966.
1966- 1980	Resurrection and hope	SYSTRANI, the first Russian- English translation system was formed in 1970. Also, WEATHER, a machine translated forecast system was formed by the University of Montreal in 1976. A Japanese- Korean translation system was developed in 1978 too by a Japanese firm called ATLAS2.
1980- 2000	Web and new vague of translators	In 1981, a Japanese- English translator DUET was introduced by the Japanese. Hitachi too joined the race in 1986. Project C-STAR which was a trilingual translator was started in 1994.
2000- 2010	Day-to-day use	In 2005, the first translator by Google was launched. By 2008, 23% of Internet customers utilized MT and 40% considered using it for professional and personal use.

Our indignation was further narrowed down to parts of speech tagging and its methods and results in the Marathi language [7]. For Marathi, parts of speech tagging can be done in one of the ways- supervised method, unsupervised method, Rule-based tagging, stochastic method, hybrid

method, unigram, bigram, trigram and Hidden Markov Model supported by the Viterbi algorithm [8]. All these methods have been explained in detail further in the paper.

## 2. Literature Review

A number of researches have been working on machine translation since the day it was launched by IBM. All the languages around the world follow the seven steps of tokenizing, metaphorical analysis, lexeme, parts of speech tagging, chunking, parsing, and word sense disambiguation. Our study was more concentrated on machine translation in Indian languages.

While Indian languages are assumed to be morphologically rich, this striking feature brings with itself multiple provocations that make machine translation difficult. To upgrade the quality of machine translation of Indian languages, researchers have proposed a morphological structure of languages to develop a more accurate part-of-speech taggers and word sense disambiguation.

For implementing part of speech taggers in the Marathi language, mechanisms like Morph Analysers and Stemmer Analysers have been proposed. Morph Analysers give accurate grammar-related information using morphological rules. The process of extracting the word root and suffixes from the input word is known as Stemming. For accurate morphological analysis, there are several grammar rules for determining the appropriate tags in sentences. When a word has multiple meanings, the word sense disambiguation module comes into play. However, it is still difficult when unknown words come into the picture.

An early model, Anglabharti [9], embraced an example-based and rule-based methodology. The result from this model was an estimated 90% when the translation of complex sentences, which had a length of fewer than 20 words, was attempted. Using a morphological analyzer, the accuracy of the system reached a maximum of 69%. Another system Anusaraka [10] which was an English-Hindi translation system was based on a shallow parser approach and Paninian grammar formalism. The major drawback here was that word sense disambiguation could not be resolved. Furthermore, a system with a dependency parsing approach gave an accuracy of 76.5% [11]. For handling word alignment, a system implementing the Statistical phrase-based approach [12] was used. They propose a model that fragments down the treads of lexical determination and lexical reordering with the chief objective of reducing the contribution of word-alignment in machine translation. The major drawback of this was that the bag-of-words model conducted appropriately in foretelling lexical items but was not great compared to Moses when it came to ordering them. The next one was a hybrid method [13] for word alignment for English-Hindi which resulted in an accuracy of 57.06% using 270 sentences for training.

WordNet [14] was a tool introduced to overcome the drawbacks of the above mentioned approaches. The development of Hindi WordNet and the co-occurrence vector generated from Hindi Corpus is used for obtaining co-location and co-occurrence information. This information is then used to assign various meanings to unknown and ambiguous words. The accuracy result obtained is 88.92% for a dataset of 60 lexically semantic ambiguous words. Many researchers worked on an elaborative and vast version of the Hindi WordNet. Their method was derived mathematically for fuzzy relations and the configuration of the fuzzy relations for the broadened version [15]. They display the idea of arrangement of fuzzy relations that can be utilized to deduce a relation among two words that or else are not face to face related to Hindi WordNet. Morphological analyses face problems due to creativity in languages, where a word that is not in the database will remain unparsed. This is known as an unknown word.

## 3. Existing Methodology

An important machine translation process in chunking. The primary role of a chunk is to separate various phrases in a given sentence. Various approaches like maximum entropy models [16] are used. There is a lot of work carried out by researchers using the above approach for chunking. Figure 3 obtained from the site of GeeksforGeeks depicts an example of chunking of different parts of a sentence.

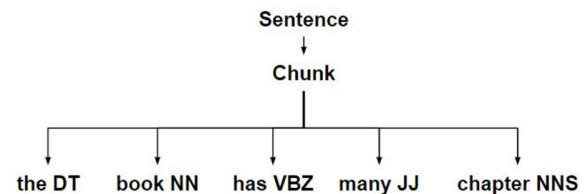

Figure 3. Example of chunking of an English sentence

Clearly, parts of speech tagging does a crucial role in machine translation. Parts of speech [17] gives us the details and also the context of the words that is to be processed. Natural language processing jobs involve syntax rules, semantic processing and language translation and many more. Corpus linguistics is the main research area in POS tagging. POS tagging is bifurcated in two parts that is supervised technique and unsupervised technique. Trained corpus is used in supervised method to analyse results. On the other side, in unsupervised technique, we have to train the corpus to tag our input text. Hence, supervised method is easier than the unsupervised technique.

These techniques are further bifurcated as rule-based, stochastic or statistical based and hybrid-based. Initially, rule-based technique was used which works on the set of

rules that are being stated by the experts. Researchers found it arduous to set proper rules that are to be followed. Even after setting in the most appropriate rules, still rule based technique has a few drawbacks. It fits in appropriately for the words whose rules are not specified eventually creating ambiguity. Hence, rule based approach does not predict the most accurate tag. Therefore, achieving good results and more accuracy through rule based approach is by manually stating down the in depth rules, which is an exhaustive process. Later, to achieve better accuracy in POS tagging statistical approach was analysed. As different analysts used different sets of tags, there is no one particular standardised tag set. This method, as the name suggests, is based on frequency and probability. From the trained data set best suitable tag is determined and allocated. Probabilistic features combined with manually penned protocols are used in Hybrid approach. As it uses the best characteristics of both the methods, the Hybrid method is better in comparison to rule-based and statistical methods. Major issue faced during POS tagging is ambiguity which is to be looked upon. The following section discusses the various processes of approaching the implementation of parts of speech (POS) tagger. Parts of Speech is a complete grammar clan incorporating nouns, verbs, adverbs, adjectives and many more. POS tagging is also called tagging of grammatical text, according to its meaning and context. Few of the POS taggers available for the English dialect are Tree tagger, Brill tagger, CLAWS tagger. They have utilized rule-based, stochastic, or morphological inputs. POS tagger basically registers the word of a certain language and assigns part of speech to every single word. Figure 4 depicts a classification of POS tagging approaches.

Further, we summarize the ways of implementing parts of speech tagging as below:

- **Supervised POS Tagging:** Mostly, probability based technique is used by statistical taggers to tag sentences [18]. The ambivalence of words encountered in this tagger with respect to the frequency of the word is equated to a certain tag. Models that are already tagged are required in this method. N-gram techniques unveil the best tag for the input text with the probability estimated through its previous tags. The flipside is, it reposes appropriate tags in sequential order.
- **Unsupervised POS Tagging:** There is no requirement of already tagged models in this POS [19]. To reflexively commence the tag props and modification rules, this procedure uses computational strategies like the Baum-Welch algorithm [20].

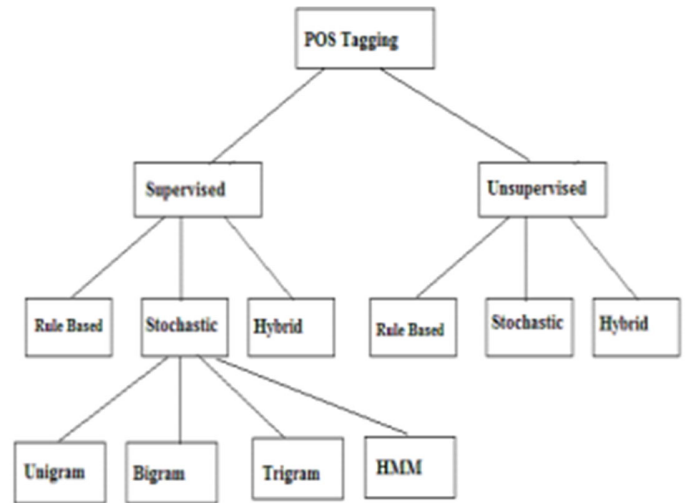

Figure 4. Classification of POS tagging approaches

- **Rule-based POS Tagging:** This one is one of the most primitive techniques of tagging which uses grammatical details and manually penned rules for tagging purpose. The most commonly used rule-based method for English POS Tagger is Brill's tagger [21]. Dictionary is used for receiving a particular tag for the input text. When there is more than one probable tag for the input text, manually set protocols come into play to identify that particular tag. Ambivalence of the word encountered is overcome by inspecting its language features, the word before, the word after and other details.
- **Stochastic Models:** Frequency and statistics are enclosed in this model. These models are constructed on different approaches like Maximum Likelihood Estimation (MLE) [22], n-grams [23], or Hidden Markov Models (HMM). Downside is occasional sequences are generated by tags.
- **Hybrid Models:** Hybrid models use the best of both the methods that are Statistical and rule based approaches to obtain best results. First the statistical method is applied to get the correct tag and if it's inappropriate then rule based technique is applied to get the right tag.
- **Unigram:** It allots a generic tag to every word considering one at a given time. It is a 1-gram tagger that allots each and every word to a tag which complements the best to it. Explicated data is utilized to train the corpus shown in Figure 5.

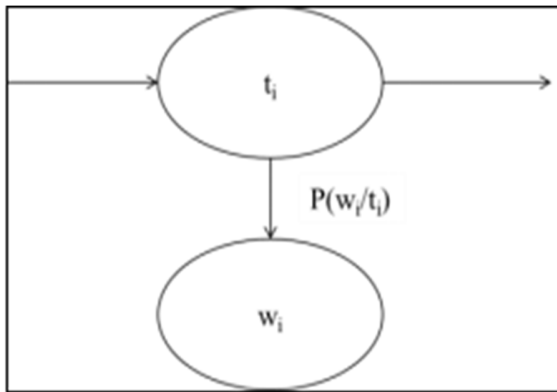

Figure 5. Unigram Model

- **Bigram:** Sequences of tag are produced in this method. tag is allocated to a word depending upon the previous tag. The Bigram model is depicted in Figure 6. In this tagger method it is assumed that the probability of the tags hangs on the previous tag.

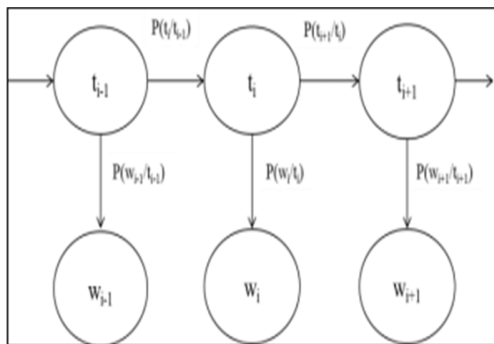

Figure 6. Bigram Model

- **Tri gram Model:** Here the best tag is unveiled, when we are being provided with the earlier two tags. Consider  $t_1, t_2, t_3$  so on upto  $t_n$  is the tag sequence and  $w_1, w_2, w_3$  so on upto  $w_n$  is the word sequence. See Figure 7 for the Trigram model.
- **Hidden Markov Model (HMM):** HMM based POS tagger assigns the most appropriate tag to a word by designing forward and backward probabilities of tags along with the sequence that is being given as an input. The following equation constitutes this procedure.

$$P\left(\frac{t_i}{w_i}\right) = P\left(\frac{t_i}{t_{i-1}}\right)P\left(\frac{t_{i+1}}{t_i}\right)P\left(\frac{w_i}{t_i}\right)$$

$P\left(\frac{t_i}{t_{i-1}}\right)$  is the probability of the existing tag given the prior tag.

$P\left(\frac{t_{i+1}}{t_i}\right)$  is the probability of the succeeding tag given a present tag.

$P\left(\frac{w_i}{t_i}\right)$  is the probability of the current tag, which is deliberated as

$$P\left(\frac{w_i}{t_i}\right) = \frac{freq\left(\frac{t_i}{w_i}\right)}{freq(t_i)}$$

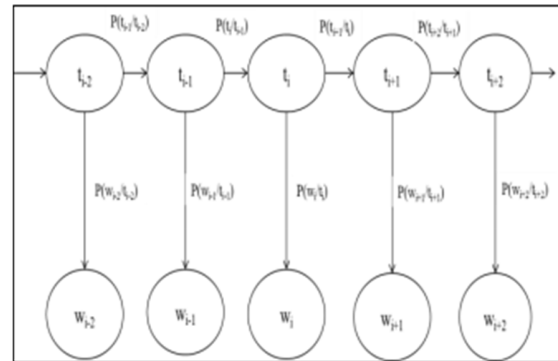

Figure 7. Trigram Model

To summarize the above techniques Table 2 depicts the performance for various languages.

Table 2. POS Tagging Techniques

Technique	Description	Accuracy
Rule-Based	Uses a set of handwritten rules	Sanskrit-89% Marathi-79.82% Hindi- 96.28%
Stochastic	N previous tags	Marathi- unigram, bigram, trigram, HMM-78%, 90.38%, 91.5%, 93.87%
Hybrid	Assigns most probable tag	Hindi- 79.85% Bengali-95.32%

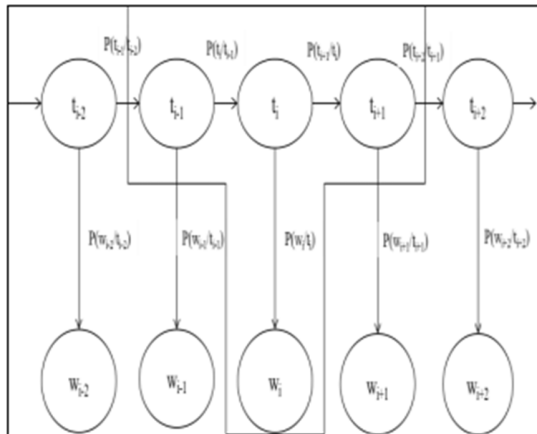

Figure 8. Hidden Markov Model

To narrow down all the approaches of machine translation and POS Tagging, table 3 depicts a comparison of all the translation techniques [34].

Table 3. Comparison between MT Techniques

MT Approach	Advantages	Disadvantages
<b>Rule-Based</b>	1) Simple to construct information on language basis. 2) good in core phenomenon and domain specific translation.	1) Arduous to maintain and not very effective in management phenomenon. 2) For general translation, the number of protocols grows dramatically.
<b>Knowledge-Based</b>	1) Has taxonomy of knowledge 2) Contains inference engine and has interlingual representation	1) Hard to build hierarchy and specify granularity of knowledge. 2) difficult to express and bring out the information acquired.
<b>Example-Based</b>	1) Extracts knowledge from corpus and reduces human cost 2) Based on translation patterns in corpus	1) Knowledge acquisition problem exists. 2) Search cost is more
<b>Statistical</b>	1) Extracts knowledge from corpus and reduces human errors. 2) Does not consider language grammar for translation. 3) Model is mathematically grounded	1) No semantic framework 2) The exploration price is high and uses a huge amount of corpus. 3) The translation quality will be very bad because of the lack of corpus.

After considering all the methods, we narrowed down our research to POS tagging in Marathi language using the Hidden Markov Model as it is the most reliable and easy to

implement. Using the Viterbi algorithm with HMM appeared to be the best approach. We used different parts of speech by using Trigrams'n'Tags (TNT) [24] that uses a second-order Hidden Markov Model and Viterbi algorithm [25]. This can be explained with the help of a flow chart. Take a text file in Standard Format. This format takes input and output specification with part of speech tagging, Chunk and morphological analyzer with the information of feature such as root, gender category, person, number, case, etc. convert this standard format in TNT format, this create a subdirectory of the text file apply Viterbi algorithm for parts of speech tagging. For unknown words we apply suffix smoothing. This method will improve the result of Part of speech tagging. Figure 9 depicts the flow of POS tagging of Marathi sentences using the HMM and Viterbi algorithm.

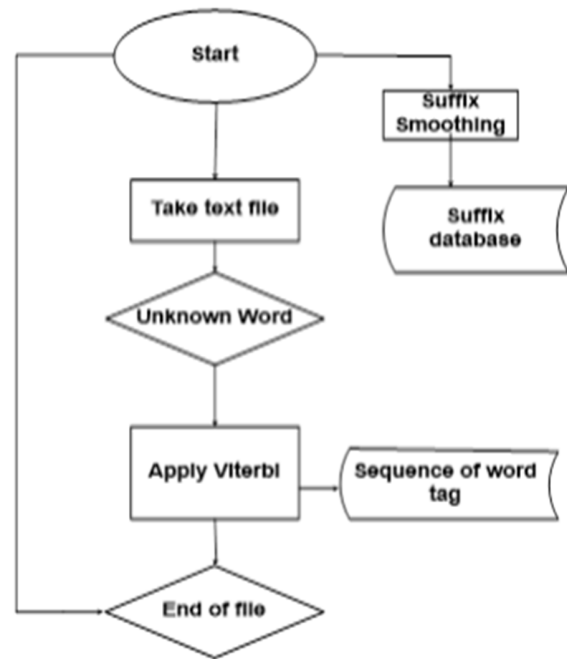

Figure 9. Flowchart of POS

This model gave an accuracy of about 93% for POS tagging in Marathi on a dataset of about fifty lakh Marathi sentences divided into testing and training dataset. It tagged the tags mentioned in below Table 4.

**Table 4-** Tags and Description

S.No.	Tag	Description
1	NN	Common Noun
2	NST	Spatial/ Temporal Expression Noun
3	NNP	Proper Noun
4	PRP	Pronoun
5	DEM	Demonstrative
6	VM	Verb Main
7	VAUX	Verb Auxiliary
8	JJ	Adjective
9	RB	Adverb
10	PSP	Postposition
11	RP	Particles
12	QF	Quantifiers
13	QC	Cardinals
14	CC	Conjuncts
15	WQ	Question Words
16	QO	Ordinals
17	INTF	Intensifier
18	INJ	Interjection
19	NEG	Negative
20	SYM	Symbols
21	XC	Compounds
22	RDP	Reduplication
23	ECH	Echo Words
24	UNK	Unknown

A major issue while translating Marathi sentences is that of multi-sense words, for example, Marathi word 'uttar' contains multi-sense meaning in English 'answer', 'North', 'reply', and another meaning in English is 'response'.

Therefore, the same words represent multiple tags in given Parts of Speech, polysemy words have different senses in specified domains and to dig out the proper purport in words having multiple meanings in Marathi language is a challenge. To resolve this ambiguity there is a methodology based on Morphological Analysis, Part of Speech tagging, Parsing, and Word sense disambiguation. We have used machine learning methods and domain-specific sense with the information of the WordNet tool [26]. This approach and method will resolve the problem of Word Sense Disambiguation. There are various translating websites available too like Google Translator [27] and Babelfish Translator [28] but they failed to resolve polysemy words in Marathi to English Translation.

## Conclusion

This paper embellished about Machine Translation and various techniques to conduct it. It also ornamented some issues regarding machine translation like chunking, word sense disambiguation, and morphological analyser. In the task of Machine Translation, word sense disambiguation plays a major role to produce a correct translation. We obey supervised, unsupervised and domain-specific sense disambiguation. We use the Marathi - English WordNet tool based on dictionary knowledge like gloss overlaps. This will enhance the performance of Word Sense Disambiguation and in turn help in improving the performance of Marathi to English language machine translation. POS tagging is one of the stepping stones in any NLP based software. Many researchers have worked on this and different POS taggers are obtained through it, each tagger having its own set of tags. All the three approaches that are Statistical, Rule-based, and Hybrid method have brought out satisfactory execution outputs. But the arduous job is to produce adept POS taggers for a huge training corpus resulting in best accuracy for the selected language. The Hidden Markov model used with the Viterbi algorithm gave the best results for Marathi POS tagging to date. In the future, there is an ardent need to expand the amount of tagged corpus and train POS taggers incorporating the tagged corpus to produce better results.

## References

- [1] Wlodek Zadrozny, Valeria de Paiva, Lawrence S. Moss. Explaining Watson: Polymath Style. Proceedings of the Twenty-Ninth AAAI Conference on Artificial Intelligence.

- [2] Hemant Darbari, Iti Mathur, Nisheeth Joshi. 2013. Human and Automatic Evaluation of English-Hindi Machine Translation
- [3] Shachi Mall, Umesh Chandra Jaiswal. Survey: Machine Translation for Indian Language. *International Journal of Applied Engineering Research* ISSN 0973-4562 Volume 13, Number 1 (2018) pp. 202-209.
- [4] Mr. Nadeem Jadoon Khan, Mr. Waqas Anwar, Mr. Nadir Durrani. Machine Translation Approaches and Survey for Indian Languages.
- [5] Luchezar Jackov. Institute for Bulgarian Language Bulgarian Academy of Sciences. Feature-Rich Part-Of-Speech Tagging Using Deep Syntactic and Semantic Analysis.
- [6] Vikas Yadav, Steven Bethard. A Survey on Recent Advances in Named Entity Recognition from Deep Learning models.
- [7] Nisheeth Joshi, Hemant Darbari, Iti Mathur. Center for Development of Advanced Computing, Pune, Maharashtra, India, Department of Computer Science, Banasthali University, India. Hmm based tagging for the Hindi language.
- [8] Suvarna G Kanakaraddi, Suvarna S Nandyal. Survey on Parts of Speech Tagger Techniques. *Proceeding of 2018 IEEE International Conference on Current Trends toward Converging Technologies*, Coimbatore, India.
- [9] Pammi, S. C., & Prahallad, K. (2007, January). POS tagging and chunking using decision forests. In *IJCAI Workshop on Shallow Parsing for South Asian Languages* (pp. 33-36).
- [10] Hettige, B., & Karunananda, A. S. (2006, August). A Parser for Sinhala Language-First Step Towards English to Sinhala Machine Translation. In *First International Conference on Industrial and Information Systems*
- [11] Sugandhi, R. S., Shekhar, R., Agarwal, T., Bedi, R. K., & Wadhai, V. M. (2011, December). Issues in Parsing for Machine Aided Translation from English to Hindi. In *Information and Communication Technologies (WICT), 2011 World Congress on* (pp. 754-759). IEEE.
- [12] Ambati, B. R., Husain, S., Jain, S., Sharma, D. M., & Sangal, R. (2010, June). Two methods to incorporate local morphosyntactic features in Hindi dependency parsing. In *Proceedings of the NAACL HLT 2010 First Workshop on Statistical Parsing of Morphologically Rich Languages* (pp. 22-30). Association for Computational Linguistics.
- [13] Venkatapathy, S., & Bangalore, S. (2009). Discriminative machine translation using global lexical selection. *ACM Transactions on Asian Language Information Processing (TALIP)*, 8(2), 8.
- [14] Saktel, P., & Shrawankar, U. (2012, March). Context-based Meaning Extraction for HCI using WSD algorithm: A review. In *Advances in Engineering, Science and Management (ICAESM), 2012 International Conference on* (pp. 208-212). IEEE.
- [15] Agarwal, M., & Bajpai, J. (2014, August). Correlation-based Word Sense Disambiguation. In *Contemporary Computing (IC3), 2014 Seventh International Conference on* (pp. 382-386). IEEE.
- [16] Sastry, G. R., Chaudhuri, S., & Reddy, P. N. (2007). An HMM-based Part-Of-Speech tagger and statistical chunker for 3 Indian languages. *Shallow Parsing for South Asian Languages*, 13.
- [17] Sunitha, C. (2015, August). A hybrid Parts Of Speech tagger for the Malayalam language. In *Advances in Computing, Communications, and Informatics (ICACCI), 2015 International Conference on* (pp. 1502- 1507). IEEE.
- [18] Swati Tyagi, Gouri Shankar Mishra. Statistical analysis of part of speech tagging algorithms for English corpus. *International Journal of Advanced Research, Ideas and Innovations in Technology*
- [19] Omid Kashef. Unsupervised Part-of-Speech Induction. Intelligent Systems Program University of Pittsburgh.
- [20] [https://en.wikipedia.org/wiki/Baum-Welch\\_algorithm](https://en.wikipedia.org/wiki/Baum-Welch_algorithm)
- [21] Beáta Megyesi. Brill's rule-based PoS tagger. Department of Linguistics University of Stockholm Extract from D-level thesis.
- [22] <https://towardsdatascience.com/probability-concepts-explained-maximum-likelihood-estimation-c7b4342fdbb1>
- [23] Daniel Jurafsky & James H. Martin. *Speech and Language Processing. N-gram Language Models*. Draft of October 2, 2019.
- [24] Berenike Litz, Hagen Langer, and Rainer Malaka. TRIGRAMS'n'TAGS FOR LEXICAL KNOWLEDGE ACQUISITION. University of Bremen, Germany
- [25] Christina-Elisavet Pertsinidou and Nikolaos Limnios. Viterbi algorithms for Hidden semi-Markov Models with application to DNA Analysis.
- [26] <https://wordnet.princeton.edu>
- [27] Timothy R. Giannetti. St. John Fisher College. Google Translate as a Resource for Writing
- [28] Samantha Young. Babel Fish. New Jersey Governor's School of Engineering & Technology 2015
- [29] Amruta Godase1 and Sharvari Govilkar. Machine Translation Development for Indian Languages and its Approaches. *International Journal on Natural Language Computing (IJNLC)* Vol. 4, No.2, April 2015.
- [30] Aditi Kalyani, Hemant Kumud, Shashi Pal Singh, Ajai Kumar, Hemant Darbari. Evaluation and Ranking of Machine Translated Output in Hindi Language using Precision and Recall Oriented Metrics. *International Journal of Advanced Computer Research (ISSN (print): 2249-7277 ISSN (online): 2277-7970) Volume-4 Number-1 Issue-14 March-2014*.
- [31] Ankita Agarwal, Pramila, Shashi Pal Singh, Ajai Kumar, Hemant Darbari. Morphological Analyser for Hindi A Rule-Based Implementation. *International Journal of Advanced Computer Research (ISSN (print): 2249-7277 ISSN (online): 2277-7970) Volume-4 Number-1 Issue-14 March-2014*.
- [32] Shashi Pal Singh, Ajai Kwnar, Hemant Darbari, Lenali Singh, Anshika Rastogi, Shikha Jain. Machine Translation using



- Deep Learning: An Overview. 2017 International Conference on Computer, Communicatio
- [33] ns, and Electronics (Comptelix) Manipal University Jaipur, Malaviya National Institute of/Technology Jaipur & IRISWORLD, July 01-02,2017.
- [34] Shashi Pal Singh, Ajai Kumar, Hemant Darbari, Lenali Singh, Nisheeth Joshi, Priya Gupta, and Sneha Singh. Intelligent System for Automatic Transfer Grammar Creation using Parallel Corpus.
- [35] G V Garje, G K Kharate. Survey of Machine Translation Systems in India. International Journal on Natural Language Computing (IJNLC) Vol. 2, No.4, August 2013.
- [36] John Hutchins, (2005) "Current commercial machine translation systems and computer-based translation tools: system types and their uses", International Journal of Translation vol.17, no.1-2, pp.5-38.
- [37] Sampark: Machine Translation System among Indian languages (2009) [http://tdil-dc.in/index.php?option=com\\_vertical&parentid=74](http://tdil-dc.in/index.php?option=com_vertical&parentid=74), <http://sampark.iiit.ac.in/>



**Vijayshri Khedkar** received the B.Tech. and M.E. degrees, in 2005 and 2016, respectively. She is working as an Assistant Professor in Symbiosis Institute of Technology. Her research interest includes NLP, Machine Learning and WSN. She is a member of IEEE, IFERP, and IAENG. She is a reviewer of IJECE.



**Pritesh Shah** received the B.E. degree in instrumentation and control from Vishwakarma Government Engineering College, Ahmedabad, India, in 2005, and the M.Tech. degree in instrumentation and control and the Ph.D. degree from the College of Engineering, Pune, India, in 2007 and 2017, respectively. He is currently an Associate Professor with the Symbiosis Institute of Technology, Pune. His research interests include fractional calculus and system identification. He has applied fractional calculus and system identification in various fields, like machining, bolt joint, bio-fuelled diesel, and servomotor. He has more than 13 years of experience, including industry and academic. He is currently guiding three Ph.D. students. He has around 30 publications, including journal articles, conference papers, and book chapters.