



Print ISSN: 1738-3110 / Online ISSN 2093-7717
 JDS website: <http://www.jds.or.kr/>
<http://dx.doi.org/10.15722/jds.20.01.202201.77>

Post-Adoption of Online Shopping: Do Herding Mentality or Health Beliefs Matter?

Tai Anh KIEU¹

Received: November 25, 2021. Revised: December 17, 2021. Accepted: December 21, 2021.

Abstract

Purpose: The Covid-19 pandemic has triggered several herd purchase behaviors, and online shopping has been considered a health-related preventative behavior. This study aims to the relative impact of health threat beliefs concerning Covid-19 (perceived susceptibility and perceived severity) and herd mentality on consumers' online shopping post-adoption disconfirmation and continuance intention of online shopping. **Research design, data and methodology:** An internet survey was conducted with Vietnamese consumers, and upon screening, usable data of 292 responses were analyzed using PLS-SEM. Results showed that while herd mentality positively affects disconfirmation, health threat beliefs including perceived susceptibility and perceived severity of Covid-19 do not. **Results:** Results also provided further support for the notion that disconfirmation is a crucial determinant of post-adoption continuance intention. Moreover, herd mentality also has a significantly negative influence on online shopping post-adoption continuance intention. **Conclusions:** The research provides evidence supporting the role of herd mentality and post-adoption disconfirmation in driving consumers' intention to continue online shopping. However, the research shows that neither the perceived susceptibility of Covid-19 nor the perceived severity of Covid-19 has significant impact on post-adoption disconfirmation, adding mixed evidence to the application of health belief theory in technology (such as online shopping) adoption.

Keywords: Health Beliefs, Perceived Susceptibility of Covid-19, Perceived Severity of Covid-19, Herd Mentality, Continuance Intention, Online Shopping, Online Distribution.

JEL Classification Code: L81, M31

1. Introduction

The Covid-19 pandemic since its outbreak in early 2020 has created unprecedented upheavals, prompting people and businesses to change their way of life and course of doing business. One of the significant changes in consumer behavior is that many consumers have previously hesitated since the pandemic began to turn to or intensify online shopping because of health or safety/self-protection concerns (Standish & Bossi, 2020). According to Kim (2020), the Covid-19 pandemic has prompted 'late adopters'

to switch to online shopping for the first time. Some consumers do online shopping mainly because of tight lockdown periods. Some other consumers maintain the increased online shopping for both strict social distance and when society is in a 'new normal.' Vietnam E-Commerce Association reported that the Vietnamese e-commerce market has a very high growth rate, an average annual rate of 30%, in 2015-2019, thanks to the internet usage rate and high smartphone ownership rate. However, while 30% of consumers have done online shopping, the share of online shopping in Vietnam's total retail sales is modest, only about

¹ First author and Corresponding Author, Head of Marketing Department, Faculty of Business Administration, Ho Chi Minh City Open University, Vietnam, Email: tai.ka@ou.edu.vn

© Copyright: The Author(s)
 This is an Open Access article distributed under the terms of the Creative Commons Attribution Non-Commercial License (<http://creativecommons.org/licenses/by-nc/4.0/>) which permits unrestricted noncommercial use, distribution, and reproduction in any medium, provided the original work is properly cited.

10%, and still behind other ASEAN countries such as Indonesia, Thailand, and Singapore (McKinsey & Company, 2019). Those statistics mean that most Vietnamese consumers are still hesitant and not ready to accept online shopping. A report by International Trade Administration explained that the reasons for that hesitation are that consumers do not trust online shopping, and the popularity of online payments is still low. According to the Vietnam E-commerce Association, the Covid-19 pandemic has further promoted the development of e-commerce. Specifically, when the third outbreak is close to the lunar new year of 2021, consumers have turned to online shopping for items previously purchased only directly, such as Tet flowers. According to International Trade Administration, the Government of Vietnam has also introduced many regulations and solutions, such as increasing online payments to promote e-commerce; one of the goals is to account for 50% of total retail sales in urban areas by 2025. The pandemic is complicated in many countries worldwide and Vietnam, but the pronounced effects of covid-19 vaccination allow people to be optimistic about the future after the pandemic. In the retail sector, the question for researchers and regulators is whether consumers who had hesitated to shop online before the pandemic and had begun to turn to or increase online shopping as a technology-acceptance behavior since the pandemic will continue their newly-adopted behavior.

Since the pandemic began, several researchers have suggested that consumers changed their behavior due to perceived health threats (Mehroliya, Alagarsamy, & Solaikutty, 2021; Sreelakshmi & Prathap, 2020). The link between one's health beliefs and resulting behavioral change in response to an adverse health event to protect themselves could potentially be explained by the health belief model (Rosenstock, 1974). Although the health belief theory has been updated over time, the two most common variables of the health belief model are perceived susceptibility and perceived severity (Laato, Islam, Farooq, & Dhir, 2020; Suess, Maddock, Dogru, Mody, & Lee, 2022). Accordingly, the perceived susceptibility and perceived severity of Covid-19 could explain the adoption of new and post-pandemic behaviors (Deng, Wang, Xie, Chao, & Zhu, 2020; Sreelakshmi & Prathap, 2020; Yuen, Bin Saidi, Bai, & Wang, 2021). Tan, Goh, and Lee (2006) argued that the Health Belief model remains applicable when a new infectious agent presents itself after a time-lapse. As the ongoing situation of the pandemic with recent Covid-19 variant outbreak and no end yet in sight, in the face of more people getting vaccinated, the effects of individuals' beliefs surround the threat Covid-19 on post-adoption behavior are essential to understand.

On the other hand, extant literature also suggested that technology adoption behavior could be explained by herd

mentality (Sun, 2013). Herd mentality is a state in which, in uncertain conditions, people underestimate their information and engage in imitating behavior, following the crowd (Sun, 2013). While the impact of herd psychology has been considered in the context of information technology adoption or panic buying behaviors when the Covid-19 pandemic breaks out, there is little research looking at the effects of herd psychology on consumers' post-adoption continuance behaviors. The pandemic has spread the fear of people around the world. The general fear of the crowd exacerbates the individual's anxiety, prompting them to imitate others when they think the majority's thoughts, feelings, and behaviors are right (Vedadi & Warkentin, 2020). Since herd psychology may operate in consumers' minds in such an uncertain context of the Covid-19 pandemic (Lee, Wu, & Lee, 2021), it is also essential to understand whether herd mentality was fragile and had no further effect on post-adoption behavior.

This study was conducted during May-June when social distancing measures were still loose in most areas and consumers still had a choice in shopping channels. The strict social distancing measures applied in Ho Chi Minh City from early July 2021 onwards forced most consumers to rely on online shopping. This unique situation might allow consumers to experience online shopping fully, and positive or negative disconfirmation of online shopping probably arises. Under expectancy-disconfirmation theory, disconfirmation of expectations, defined as the difference between the actual results or observed experience and the original expectations, is a crucial determinant of continuance intention (Oliver, 1980). Indeed, several previous studies have used expectancy-disconfirmation theory to explain the intention to continue using the technology (Bhattacharjee & Premkumar, 2004; Sun, 2013). Many countries, including Vietnam, have prepared to live with the Covid-19 pandemic, at least in the foreseeable future. The return to "new normal" life has allowed consumers to choose shopping channels again. It is significant to understand the role of disconfirmation in the post-adoption intention concerning online shopping.

Research that leverages and integrates these theoretical perspectives – expectancy-disconfirmation theory, health belief theory, herd psychology literature, and expectation-confirmation theory – to examine the technology post-adoption behavior in consumer behavior literature more generally and in the specific complicated context like the Covid-19 pandemic is lacking. Therefore, this study aimed to investigate the relative impact of perceived susceptibility, perceived severity, and herd mentality on the consumers' post-adoption disconfirmation and, ultimately, online shopping continuance. An online survey was conducted with Vietnamese consumers who adopted online shopping under the Covid-19 pandemic to collect quantitative data to test the

hypotheses. Respondents were screened on the criteria that they either switched from fully offline to online shopping or significantly increased online shopping due to the pandemic. The current study is novel as it integrates theoretical perspectives to predict the post-adoption of online shopping. While developed in the context of COVID-19 and online shopping, this study's integrated framework can be applied to future research that examines continuance intentions of other forms of technology adoption. The present study offers insight into developing online distribution strategies to drive post-adoption continuance behaviors from a practitioner standpoint.

2. Theoretical background

The expectancy-disconfirmation theory has been widely adopted in consumer behavior research to explain repurchase or continuance behavior (Dabholkar, Shepherd, & Thorpe, 2000; Oliver, 1980). The fundamental notion of this theory is that consumers will compare their perceived actual results to their initial expectations and form a perceived confirmation of expectations (which marketing researchers frequently refer to as disconfirmation (Oliver, 1980)). The expectancy-disconfirmation theory conceptualizes a distinction between pre-purchase attitude/intention and post-purchase attitude/intention, and disconfirmation captures the difference between initial expectations (attitude) and post-acceptance perceptions (Oliver, 1980). According to expectancy-disconfirmation theory, once a consumer confirms acceptance of online shopping and then uses it, they form perceptions of performance in terms of online shopping benefits. Satisfaction develops when perceived performance exceeds initial expectations, resulting in a continuance intention to use the service (Bhattacharjee, 2001a). Viewing disconfirmation as a deviation from initial expectations, researchers have classified disconfirmation into two types: positive disconfirmation (often referred to in short as disconfirmation) formed when the experience is better than the initial thought, and negative disconfirmation when the experience is worse than initially expected (Sun, 2013).

Bhattacharjee (2001b) argued that the expectancy-disconfirmation theory is applicable to technology adoption thanks to that distinction but suggested that the theory could be modified since the users' use of technology does not fully correspond to actual purchasing behavior. Some researchers integrated expectancy-disconfirmation theory with other technology adoption theories such as the technology acceptance model by including perceived usefulness (Bhattacharjee, 2001b; Lee, 2010) or theory of planned behavior by including subjective norms and perceived behavioral control (Kim, 2010). These works implied the

possibilities to extend or modify expectancy-disconfirmation theory and revealed that such extension could increase explanatory power for the continued use of technology. To investigate the intention to continue behaviors adopted due to the pandemic related to other Covid-19 relevant variables, this study integrated this theoretical foundation with the health belief model and herd psychology literature. Since the expectancy-disconfirmation model is well-tested as indicated by a meta-analysis (Ambalov, 2018), rather than testing all links within the model, this study only examined the relationship between disconfirmation of expectations and post-adoption continuance. In this study, adopting from Bhattacharjee (2001a), the post-adoption continuance of online shopping is defined as the degree to which a user intends to continue using online shopping. Based on the above discussions, it could be hypothesized that:

H1: Online shopping post-adoption disconfirmation has a positive influence on online shopping post-adoption continuance intention.

Initially developed in the 1950s, the health belief theory is predicated on the notion that a person's willingness to alter their behaviors is determined mainly by their health perceptions (Rosenstock, 1974). The health belief theory, also widely referred to as the health belief model, stipulates that the perceived threat of a disease, as assessed by perceived susceptibility and perceived severity, as well as other factors such as perceived barriers and perceived self-efficacy contribute to the formation of health-related protective behavior (Tan et al., 2006). The health belief model has also been widely utilized in technology adoption research. Several researchers have integrated the health belief model's perceived threat that includes perceived susceptibility and perceived severity into technology adoption theories such as the unified theory of acceptance and use of technology and the theory of planned behavior to explain technology-based health behavior (Melzner, Heinze, & Fritsch, 2014; Wei, Vinnikova, Lu, & Xu, 2021; Zhang, Liu, Luo, Xie, Liu, & Zhou, 2019; Zhao, Ni, & Zhou, 2018).

Noteworthy, most research focused on the direct link between health belief model components and technology adoption, such as mobile health application usage (Melzner et al., 2014) or the use of mobile health service (Sun, Wang, Guo, & Peng, 2013) or diabetes management application usage (Zhang et al., 2019). Other researchers also examined the indirect impact of health belief model constructs on technology adoption via technology (mobile fitness apps) performance expectancy (Wei et al., 2021). A meta-analysis of health belief model components showed that perceived threat (perceived severity and perceived vulnerability) had a substantial effect (Zhao et al., 2018). Little research has been paid to the link between the health belief model and post-

adoption. In the context of the current study, the adoption or continuance of online shopping can be viewed as a preventative health behavior that helps keep the risk of Covid-19 infection to a minimum.

Rogers (1995) suggested that once deciding on the adoption, one continues his appraisal of the technology and further decides on continuance/ discontinuance. In this regard, the adoption construct is conceived as confirmation (Humbani & Wiese, 2019; Rogers, 1995). Bhattacharjee (2001b) the confirmation, which is the realization of anticipated benefits from a technology use would drive continuance intention. Oliver (1980) viewed the post-decision deviations from ones' expectations. This study formulates hypotheses based on an integrated framework of HBM and expectancy-disconfirmation perspectives. It could be argued that disconfirmation of health-protective technology could be explained by the health belief model's constructs of perceived susceptibility and perceived severity of a disease. Since the use of online shopping becomes increasingly necessary in the event of a pandemic, the study examines perceived threat dimensions, including perceived susceptibility to and perceived severity of COVID-19 as antecedents of expectancy disconfirmation for online shopping adoption. Perceived susceptibility is defined as one's perceptions of the likelihood of encountering a potentially hazardous health condition, and perceived severity is referred to as the extent to which the condition poses a threat to that person (Sreelakshmi & Prathap, 2020). Based on the above discussions, it could be hypothesized that:

- H2:** Perceived susceptibility of Covid-19 has a positive influence on online shopping post-adoption disconfirmation.
- H3:** Perceived severity of Covid-19 has a positive influence on online shopping post-adoption disconfirmation.

In terms of technology adoption, a phenomenon that has sparked considerable interest among researchers and managers is that many people use technology and then abandon it. For instance, a challenge facing many social networks, such as Twitter or Facebook, is a large number of users who have ceased to interact on these platforms (Perrigo, 2019). Several researchers referred to this behavioral phenomenon as herd behavior (Sun, 2013; Vedadi & Warkentin, 2020). In the field of technology, information systems users may exhibit herd behavior in response to intense anxiety about personal information being exploited (Vedadi & Warkentin, 2020). Some researchers argued that the equilibrium of herd mentality is extremely fragile (Lee et al., 2021), which means that once people adopt a technology, they can re-evaluate the benefits and reverse their initial decision, resulting in widespread

abandonment of that technology (Sun, 2013). In this sense, the post-adoption abandoning behavior en masse is coincident but not herd behavior.

Researchers confirmed the importance of distinguishing herd psychology from herd behavior, as herd behavior does not always reflect an intention to imitate but can sometimes represent the same behavior based on the same available information inadvertently (Wu & Lin, 2017). In uncertain situations, herd mentality is a state in which individuals underestimate their information and imitate the crowd's behavior regardless of their own information, suggesting a different approach to problem-solving (Sun, 2013). Indeed, herd mentality and behavior have been prominent since the start of the Covid-19 pandemic (Prentice, Quach, & Thaichon, 2021). When the pandemic began in early 2020, people worldwide were fearful of the spread of the disease, the scarcity of health protection equipment and information from the media and online; and the pervasive fear of the majority in society has exacerbated individual anxiety (Lee et al., 2021). This sense of insecurity has sparked a panic buying spree in a wide variety of products, from masks to instant noodles to toilet paper, in many countries (Moran, 2020). Most research has concentrated on herd behavior during the pandemic (Lee et al., 2021; Moran, 2020). Few publications examine the impact of herd mentality on consumer perceptions and behavior, which is critical for forecasting the continuation of pandemic-related behaviors.

Extant herd literature suggests two dimensions of herding: underestimating one's own information and imitating others (Sun, 2009). There is empirical evidence that imitation reduces negative disconfirmation following technology adoption (Sun et al., 2013). Specifically, en-masse imitation demonstrates that an individual may have a low initial expectation, thereby increasing the probability of the expectation being confirmed or the degree of disconfirmation. Besides, the University of Oxford (2010) research revealed that once a product or service falls short of the required level of popularity, customers will abandon it. In this regard, the post-adoption continuance (or discontinuance) behavior is still a herd one. Researchers also suggested that herd mentality is a factor demonstrating social influence on an individual's behavior by researchers (Folkestad, 2016; Onnela & Reed-Tsochas, 2010). Thus, herd mentality could potentially be a determinant of post-adoption intention. Prior research provided evidence that herd mentality caused the discontinuance of technology use (Perrigo, 2019; University of Oxford, 2010; Vedadi & Warkentin, 2020). Based on the above discussions, it could be hypothesized that:

- H4:** Herd mentality has a positive influence on online shopping post-adoption disconfirmation.
- H5:** Herd mentality has a negative influence on online

shopping post-adoption continuance intention.

Figure 1 presents a visual representation of the hypothesized relationships discussed above.

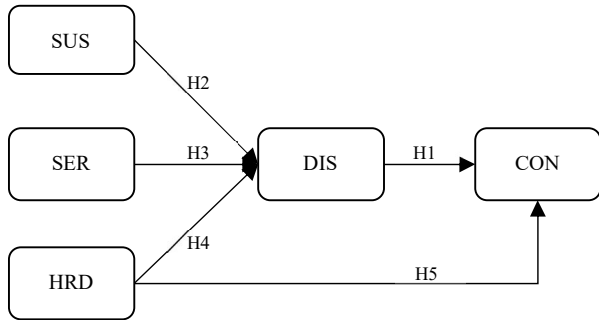

Note: CON: Online shopping continuance intention; DIS: Online shopping post-adoption disconfirmation; SUS: Perceived Susceptibility of Covid-19; SER: Perceived Severity of Covid-19; HRD: Herd mentality.

Figure 1: The proposed research model.

3. Methodology

Data were collected during May – June 2021 using a survey with a convenience sample of Vietnamese customers who answered screening questions that they switched to online shopping for the first time or significantly increased online shopping since the outbreak of the Covid-19 pandemic. Due to the nonexistence of a sampling frame of those who adopted online shopping under the pandemic, the convenience sampling method was proper (Cooper & Schindler, 2011). Google-form-based questionnaire link was posted on online forums and social media. The questionnaire included screening questions, statements of scales adapted from the literature, and demographic questions. Respondents rated their agreement/disagreement to the statements using a 5-point Likert scale, with 1 completely disagree and 5 completely agree.

The study adopted scales with good psychometric properties from previous studies to measure the concepts in the research model. Specifically, the scale of herd mentality was adopted from Sun (2013) as a second-order construct consisting of two dimensions – discounting one’s information and imitating others; perceived susceptibility and perceived severity of Covid-19 from Sreelakshmi and Prathap (2020); disconfirmation of expectation and continuance intention from Bhattacharjee (2001b). The scale statements are first translated from English to Vietnamese and next back-translated. Then, the two English versions (original and back-translated) were compared, and the translation was adjusted to ensure the content equivalence. After being designed, the survey questionnaire

was pilot-tested to ensure that the content and instructions were free of misunderstandings and grammatical errors.

The research stopped collecting data after 308 responses were collected. According to Hair, Black, Babin, and Anderson (2010), a previously required sample size of 300 may not be appropriate, but 200 is sufficient to perform SEM estimation procedures. After screening for careless responses such as the same rating for almost or all items, usable data of 292 was analyzed to assess scales and test hypotheses using PLS-SEM on SmartPLS 3.3.3 software. PLS-SEM was chosen since this method is suited to predict variables and does not require data assumption of data normality (Hair, Risher, Sarstedt, & Ringle, 2019).

4. Results and Discussion

4.1. Results

Table 1 presents descriptive statistics of the sample.

Table 1: Descriptive statistics

Demographic characteristics	N=292	%
Gender		
Male	118	40.4
Female	174	59.6
Education		
Up to high school	2	0.7
College / vocational school	24	8.2
University	140	47.9
Postgraduate	126	43.2
Age		
18 – 30 yrs. old	98	33.6
31 – 45 yrs. old	111	38.0
46 – 60 yrs. old	71	24.3
Above 60 yrs. old	12	4.1
Monthly Income		
Below 5 million VND	61	20.9
5 to less than 10 million VND	34	11.6
10 to less than 20 million VND	69	23.6
20 to less than 30 million VND	33	11.3
Above 30 million VND	95	32.5

Note: 1 million VND ≈ USD 45 (as of November 2021)

An examination of descriptive statistics showed that in the research sample, there was a higher percentage of women (about 60%) than men (40.4%); most of them have a university degree or higher (about 90% have a bachelor’s degree). Undergraduate and graduate, the sample composition is relatively young, with 33.6% under 30 years old and 38% between 31 and 45 years old. The income group of over 30 million Vietnamese Dong accounts for the highest

proportion, almost one-third of the total sample number.

Because the research adopted scales from previous studies, the structures of the latent variables have been theoretically determined, thereby using confirmatory factor analysis criteria to assess scales would be appropriate (Hair et al., 2010). The current study analyzed the data using SmartPLS 3.3.3 software. The SmartPLS-based model includes the measurement and structure models (Hair, Hult, Ringle, & Sarstedt, 2016). As suggested by Hair et al. (2019), the study assessed the scale in terms of reliability, convergent validity, and discriminant validity. Specifically, outer loadings were examined to assess item reliabilities with recommended and minimum thresholds of 0.7 and 0.5, respectively. Cronbach's alpha and composite reliability (CR) coefficients were used to evaluate internal consistency with the recommended thresholds of 0.7 and 0.6, respectively, and convergent validity would be deemed satisfactory if the average variance extracted (AVE) values were greater than 0.5 (Hair et al., 2016). In the first run, all parameter values but the AVE value for herd mentality were satisfactory. An observed variable of imitating others factor was removed, and the model was re-run. While one first-order factor (DOI) was below 0.7, it was still well above the acceptable threshold of 0.6 (Hair et al., 2010). The results in Table 2 show that Cronbach's Alpha, CR, and AVE values meet the respective requirements as above, demonstrating scale reliability and convergent validity.

Table 2: The reliability and convergent validity

Variables	Factor loadings	Cronbach Alpha	CR	AVE
CON	[0.883 - 0.945]	0.937	0.955	0.842
DIS	[0.882 - 0.909]	0.879	0.926	0.806
SUS	[0.819 - 0.936]	0.855	0.902	0.756
SER	[0.626 - 0.939]	0.811	0.843	0.580
HRD			0.580	0.730
DOI	[0.677 - 0.835]	0.638	0.804	0.579
IMO	[0.939 - 0.941]	0.868	0.938	0.883

Note: CON: Online shopping continuance intention; DIS: Online shopping post-adoption disconfirmation; SUS: Perceived Susceptibility of Covid-19; SER: Perceived Severity of Covid-19; HRD: Herd mentality (second-order reflective construct consisting of DOI and IMO); DOI: discounting own information; IMO: Imitating others.

Discriminant validity of the scales was assessed using the criteria of Heterotrait-Monotrait (HTMT) values of less than 0.9, as suggested by Hair et al. (2019). Results in Table 3 shows that HTMT values of concept pairs are less than 0.9, thereby scales' discriminant validity was satisfactory.

The SmartPLS output regarding collinearity statistics showed that VIF values of latent variables ranged from 1.001 to 1.252, thereby multi-collinearity being not an issue in this study as suggested by Hair et al. (2010).

Table 3: Heterotrait-Monotrait Ratio (HTMT)

	CON	SER	SUS	DIS
SER	0.081			
SUS	0.073	0.462		
DIS	0.760	0.088	0.086	
HRD	0.203	0.112	0.122	0.312

Note: CON: Online shopping continuance intention; DIS: Online shopping post-adoption disconfirmation; SUS: Perceived Susceptibility of Covid-19; SER: Perceived Severity of Covid-19; HRD: Herd mentality.

The adjusted coefficient of determination (R^2) of continuance intention is 0.483, showing that the model explains 48.3% of online shopping continuance intention variation. Besides, the adjusted R^2 value of disconfirmation is 0.062, indicating that the three antecedents explained only 6.2% of online shopping post-adoption disconfirmation variation.

The study also performed the SmartPLS blindfolding procedure to examine Q^2 , another means of assessing predictive accuracy with the system's suggested omission distance of twelve. Results also showed that Q^2 values of continuance intention and disconfirmation are 0.403 and .042, respectively. As all Q^2 values are larger than zero, the findings indicated that continuance intention and disconfirmation have predictive relevance with their respective predecessors, as Hair et al. (2019) proposed.

The size of the effect of herd mentality on online shopping post-adoption disconfirmation and online shopping continuance intention was deemed small, with f^2 being 0.062 and 0.016, respectively. Meanwhile, the path from online shopping post-adoption disconfirmation to online shopping continuance intention had a large effect size, $f^2=0.934$. The effect sizes of both health belief antecedents of online shopping post-adoption disconfirmation were very minimal, $f^2=0.002$ for the perceived susceptibility of Covid-19 and $f^2=0.007$ for the perceived severity of Covid-19.

The PLS-SEM was also run using the bootstrapping method to test the research hypotheses and model. As in Table 4, the results showed that H1, H4, and H5 were supported. This means that both disconfirmation and herd mentality significantly and positively affect online shopping post-adoption disconfirmation. The result also suggests that herd mentality significantly and negatively affects online shopping post-adoption continuance intention. H2 and H3 were not supported. Both health threat beliefs, perceived susceptibility, and perceived severity of Covid-19 do not affect online shopping post-adoption disconfirmation as anticipated based on the health belief model and prior literature.

Table 4: Hypothesis testing results

	Reg. Coeff.	Std. Dev.	t values	p values	Results ⁽¹⁾
H1	0.717	0.038	18.712	0.000	Supported
H2	0.053	0.078	0.560	0.576	Not supported
H3	0.084	0.097	0.899	0.369	Not supported
H4	0.238	0.069	3.500	0.001	Supported
H5	-0.093	0.046	2.007	0.045	Supported

Note: Reg. Coeff.: Regression coefficients; Std. Dev.: Standard deviation; ⁽¹⁾: at $\alpha = 5\%$

With H1, H4, and H5 having been supported, the mediating role of disconfirmation on the link between herd mentality and online shopping post-adoption continuance intention was also examined, using the results from bootstrapping method as suggested by (Preacher & Hayes, 2008). The results showed that the indirect effect from herd mentality to online shopping post-adoption continuance intention via disconfirmation was statistically significant (statistic=0.171, $p=0.001 < 0.05$). This significantly positive indirect effect, coupled with the significantly negative direct effect of herd mentality on online shopping post-adoption continuance intention, made the total effects statistically insignificant (statistic=0.078, $p=0.278 > 0.05$).

4.2. Discussion

The result of H1 was consistent with expectancy – disconfirmation theory and prior research that disconfirmation of expectations is an important driver of post-adoption continuance intention (Oliver, 1980; Sreelakshmi & Prathap, 2020; Sun, 2013). The absence of the satisfaction construct as a mediator in the relationship between disconfirmation and continuance intention in this research, as usually hypothesized in some prior research such as Sreelakshmi and Prathap (2020), could explain the high regression coefficient for disconfirmation ($\beta = 0.717$, $p < 0.001$). Therefore, the size of the effect of disconfirmation on continuance intention should be interpreted as the total effects from disconfirmation to continuance intention. Nonetheless, this research focused on the impact of health beliefs on the post-adoption stage, as the research integrated the health belief model and herd psychology literature into expectancy-disconfirmation theory.

H2 was not supported, meaning that the perceived susceptibility of Covid-19 did not have a statistically significant impact on online shopping disconfirmation. They do not see that online shopping can help reduce the chance of getting infectious with Covid-19. Neither was H3, indicating that the perceived severity of Covid-19 did not have a statistically significant impact on online shopping disconfirmation. Thus, they do not see that online shopping can further reduce the chance of bearing the consequences of the Covid-19 infection. Both results of H2 and H3 were

inconsistent with the research of Sreelakshmi and Prathap (2020), which examined the perceived susceptibility and the perceived severity of Covid-19 on mobile-based payment in India. The H2 and H3 findings meant that in the context of this study, perceptions of the health threat of Covid-19 do not contribute to the positive appraisal of online shopping benefits. A plausible explanation is that Vietnamese consumers have not fully grasped the benefits of online shopping. They might still view online shopping as either a convenient or forced choice due to strict social distancing measures rather than a preventative way to avoid physical contact in time of the pandemic.

The result of supported H4 was consistent with Sun (2009, 2013). Though the size of the regression coefficient for herd mentality impacting disconfirmation is modest ($\beta=0.238$, $p=0.001$), the finding suggested that people may discount their own information about the technology and imitate others in adopting technologies. Subsequently, the the-crowd-is-right belief could contribute to their positive disconfirmation of technology expectations. One reason is that when consumers discount their own information, they lower their expectations. Another reason is that consumers are more susceptible to social influence and believe that others may know the technology better since herd mentality represents the social influence on one’s behavior (Folkestad, 2016). However, the statistically significant impact of herd mentality on disconfirmation should not be merely interpreted as in the argument of Sun (2009) that people do not rely on their own information about technology, but they herd to make decisions. Because the other focus of this study is on the impact of herd mentality on the post-adoption stage as it integrated herd psychology literature into expectance-disconfirmation theory, this study only argued that herd mentality is one possible explanation for post-adoption disconfirmation.

The result of supported H5 is noteworthy as it further supports the argument that herding is not as fragile in the technology adoption context as in the finance or economics fields (Sun, 2013; Vedadi & Warkentin, 2020). The finding was consistent with earlier research that users adopted technology and might follow the crowd and abandon the technology en masse either because of its popularity (Perrigo, 2019; University of Oxford, 2010) or the crowd boycotting (El-Manstrly, Ali, & Line, 2021). While the total effects of herd mentality on post-adoption continuance intention is statistically insignificant ($\beta_{total}=0.078$, $p=0.278 > 0.05$), the combined findings of H5 and H4 suggested that the role of herd mentality should not be discounted. In this respect, herd mentality matters to the post-adoption stage in both ways. Specifically, herd mentality contributes to consumers’ appraisal of the expectations, thereby forming their own beliefs and wielding a social influence towards consumers’ herd

behaviors.

5. Conclusions & implications

Although the evolution of the COVID-19 pandemic is still complicated, early vaccination results in some countries encourage people to be optimistic about a post-pandemic world. Thus, this study contributes to a better understanding of consumer behavior once things return to normal. This study contributes to theoretical development by combining expectancy-disconfirmation theory, health belief theory, and herd psychology theory to examine the relative impact of the health belief model's perceived susceptibility, perceived severity, and herd mentality on post-adoption disconfirmation and, ultimately, continuance intention. In the context of the Covid-19 pandemic in Vietnam, which has resulted in technology acceptance of online shopping, the evidence provided support for the role of herd mentality and post-adoption disconfirmation in driving consumers' intention to continue online shopping. Moreover, the research adds mixed evidence to the application of health belief theory in technology adoption on the role of health threat dimensions in driving online shopping. Finally, the research contributes research evidence of consumer behavior in Vietnam, a country often mentioned in the literature calling for research in emerging markets (Le, Nguyen, & Kieu, 2020)

Practically, the examination of acceptance of technology in the form of online shopping in the unprecedented Covid-19 pandemic context could also help maintain the practical relevance of theories utilized as the theoretical foundations in this study. The study also offers insights for managers to develop online distribution strategies in the 'new normal' or possible post-pandemic period to motivate Vietnamese to continue online shopping as they have done through the pandemic. On the one hand, while perceived health threat does not significantly affect the post-adoption stage, unlike prior research on the use of health-related technologies such as mobile health service or diabetes management apps, managers of online shopping channels may need to develop effective strategies to communicate health-related benefits of online shopping. They may consider integrating online shopping platforms with contactless payment methods for consumers to fully realize the social distancing benefits of online shopping.

On the other hand, managers may promote a general attitude toward online shopping among the public, as a herd mentality mechanism will reinforce an individual's positive disconfirmation of their initial adoption decision. Managers should also closely monitor the online sentiments toward their online platforms, as consumers may herd and leave en masse if service failures or corporate social responsibility

issues arise. For example, in the context of this study, retailers/retail platforms must solve issues inhibiting adoption before the pandemic, and most complained during periods of social isolation: product quality and delivery time.

Like any other study, this study is not without its limitations. Firstly, the study has the limitations of a cross-sectional survey, so future research can be done with other methods, such as time-series data so that the results can be more generalized. Future research may also need to consider regional differences in terms of effects and consumer behaviors. Future research could look at changes in beliefs and attitudes before and after an unprecedented event like the Covid-19 pandemic to better understand the psychological process before and after accepting technology.

References

- Ambalov, I. A. (2018). A meta-analysis of IT continuance: An evaluation of the expectation-confirmation model. *Telematics and Informatics*, 35(6), 1561-1571. <https://doi.org/10.1016/j.tele.2018.03.016>
- Bhattacharjee, A. (2001a). An empirical analysis of the antecedents of electronic commerce service continuance. *Decision Support Systems*, 32(2), 201-214. [https://doi.org/10.1016/S0167-9236\(01\)00111-7](https://doi.org/10.1016/S0167-9236(01)00111-7)
- Bhattacharjee, A. (2001b). Understanding Information Systems Continuance: An Expectation-Confirmation Model. *MIS Quarterly*, 25(3), 351-370. <https://doi.org/10.2307/3250921>
- Bhattacharjee, A., & Premkumar, G. (2004). Understanding Changes in Belief and Attitude toward Information Technology Usage: A Theoretical Model and Longitudinal Test. *MIS Quarterly*, 28(2), 229-254. <https://doi.org/10.2307/25148634>
- Cooper, D. R., & Schindler, P. S. (2011). *Business research methods* (11th ed.). New York: McGraw-Hill.
- Dabholkar, P. A., Shepherd, C. D., & Thorpe, D. I. (2000). A comprehensive framework for service quality: An investigation of critical conceptual and measurement issues through a longitudinal study. *Journal of Retailing*, 76(2), 139-173. [https://doi.org/10.1016/S0022-4359\(00\)00029-4](https://doi.org/10.1016/S0022-4359(00)00029-4)
- Deng, S., Wang, W., Xie, P., Chao, Y., & Zhu, J. (2020). Perceived Severity of COVID-19 and Post-pandemic Consumption Willingness: The Roles of Boredom and Sensation-Seeking. *Frontiers in Psychology*, 11, 567784. <https://doi.org/10.3389/fpsyg.2020.567784>
- El-Manstrly, D., Ali, F., & Line, N. (2021). Severe service failures and online vindictive word of mouth: The effect of coping strategies. *International Journal of Hospitality Management*, 95, 102911.
- Hair, J. F., Black, W. C., Babin, B. J., & Anderson, R. E. (2010). *Multivariate data analysis* (7th ed.). Upper Saddle River, NJ: Prentice Hall.
- Hair, J. F., Hult, G. T. M., Ringle, C., & Sarstedt, M. (2016). *A primer on partial least squares structural equation modeling (PLS-SEM)*: Sage Publications.
- Hair, J. F., Risher, J. J., Sarstedt, M., & Ringle, C. M. (2019). When

- to use and how to report the results of PLS-SEM. *European Business Review*, 31(1), 2-24. <https://doi.org/10.1108/EBR-11-2018-0203>
- Humbani, M., & Wiese, M. (2019). An integrated framework for the adoption and continuance intention to use mobile payment apps. *International Journal of Bank Marketing*, 37(2), 646-664. <https://doi.org/10.1108/ijbm-03-2018-0072>
- Kim, B. (2010). An empirical investigation of mobile data service continuance: Incorporating the theory of planned behavior into the expectation–confirmation model. *Expert Systems with Applications*, 37(10), 7033-7039. <https://doi.org/10.1016/j.eswa.2010.03.015>
- Kim, R. Y. (2020). The Impact of COVID-19 on Consumers: Preparing for Digital Sales. *IEEE Engineering Management Review*, 48(3), 212-218. <https://doi.org/10.1109/EMR.2020.2990115>
- Laato, S., Islam, A. K. M. N., Farooq, A., & Dhir, A. (2020). Unusual purchasing behavior during the early stages of the COVID-19 pandemic: The stimulus-organism-response approach. *Journal of Retailing and Consumer Services*, 57, 102224. <https://doi.org/10.1016/j.jretconser.2020.102224>
- Le, T. D., Nguyen, P. N. D., & Kieu, T. A. (2020). Ethical Consumption in Vietnam: An Analysis of Generational Cohorts and Gender. *The Journal of Distribution Science*, 18(7), 37-48. <https://doi.org/10.15722/jds.18.7.202007.37>
- Lee, M.-C. (2010). Explaining and predicting users' continuance intention toward e-learning: An extension of the expectation–confirmation model. *Computers & Education*, 54(2), 506-516. <https://doi.org/10.1016/j.compedu.2009.09.002>
- Lee, Y.-C., Wu, W.-L., & Lee, C.-K. (2021). How COVID-19 Triggers Our Herding Behavior? Risk Perception, State Anxiety, and Trust. *Frontiers in Public Health*, 9(46). <https://doi.org/10.3389/fpubh.2021.587439>
- Mehroliya, S., Alagarsamy, S., & Solaikutty, V. M. (2021). Customers response to online food delivery services during COVID-19 outbreak using binary logistic regression. *International Journal of Consumer Studies*, 45(3), 396-408. <https://doi.org/10.1111/ijcs.12630>
- Melzner, J., Heinze, J., & Fritsch, T. (2014). Mobile Health Applications in Workplace Health Promotion: An Integrated Conceptual Adoption Framework. *Procedia Technology*, 16, 1374-1382. <https://doi.org/10.1016/j.protcy.2014.10.155>
- Oliver, R. L. (1980). A Cognitive Model of the Antecedents and Consequences of Satisfaction Decisions. *Journal of Marketing Research*, 17(4), 460-469. <https://doi.org/10.2307/3150499>
- Onnela, J.-P., & Reed-Tsochas, F. (2010). Spontaneous emergence of social influence in online systems. *Proceedings of the National Academy of Sciences*, 107(43), 18375. <https://doi.org/10.1073/pnas.0914572107>
- Preacher, K., & Hayes, A. (2008). Asymptotic and resampling strategies for assessing and comparing indirect effects in multiple mediator models. *Behavior Research Methods*, 40(3), 879-891. <https://doi.org/10.3758/BRM.40.3.879>
- Prentice, C., Quach, S., & Thaichon, P. (2021). Antecedents and consequences of panic buying: The case of COVID-19. *International Journal of Consumer Studies*, n/a(n/a). <https://doi.org/10.1111/ijcs.12649>
- Rogers, E. M. (1995). *Diffusion of Innovations* (4th ed.): Free Press.
- Rosenstock, I. M. (1974). Historical Origins of the Health Belief Model. *Health Education Monographs*, 2(4), 328-335. <https://doi.org/10.1177/109019817400200403>
- Sreelakshmi, C. C., & Prathap, S. K. (2020). Continuance adoption of mobile-based payments in Covid-19 context: an integrated framework of health belief model and expectation confirmation model. *International Journal of Pervasive Computing and Communications*, 16(4), 351-369. <https://doi.org/10.1108/ijpcc-06-2020-0069>
- Suess, C., Maddock, J. E., Dogru, T., Mody, M., & Lee, S. (2021). Using the Health Belief Model to examine travelers' willingness to vaccinate and support for vaccination requirements prior to travel. *Tourism Management*, 88, 104405. <https://doi.org/10.1016/j.tourman.2021.104405>
- Sun, H. (2009). Understanding Herd Behavior in Technology Adoption and Continued Use: A Longitudinal Perspective. *DIGIT 2009 Proceedings*, 11.
- Sun, H. (2013). A Longitudinal Study of Herd Behavior in the Adoption and Continued Use of Technology. *MIS Quarterly*, 37(4), 1013-1041. <https://doi.org/10.25300/MISQ/2013/37.4.02>
- Sun, Y., Wang, N., Guo, X., & Peng, Z. (2013). Understanding the Acceptance of Mobile Health Services: A Comparison and Integration of Alternative Models. *Journal of Electronic Commerce Research*, 14(2), 183-200.
- Tan, N., Goh, L., & Lee, S. (2006). Family Physicians' Experiences, Behaviour, and Use of Personal Protection Equipment During the SARS Outbreak in Singapore: Do They Fit the Becker Health Belief Model? *Asia Pacific Journal of Public Health*, 18(3), 49-56. <https://doi.org/10.1177/10105395060180030901>
- Vedadi, A., & Warkentin, M. (2020). Can secure behaviors be contagious? A two-stage investigation of the influence of herd behavior on security decisions. *Journal of the Association for Information Systems*, 21(2), 428-459. <https://doi.org/10.17705/1jais.00607>
- Wei, J., Vinnikova, A., Lu, L., & Xu, J. (2021). Understanding and Predicting the Adoption of Fitness Mobile Apps: Evidence from China. *Health Communication*, 36(8), 950-961. <https://doi.org/10.1080/10410236.2020.1724637>
- Wu, T.-Y., & Lin, C. A. (2017). Predicting the effects of eWOM and online brand messaging: Source trust, bandwagon effect and innovation adoption factors. *Telematics and Informatics*, 34(2), 470-480. <https://doi.org/10.1016/j.tele.2016.08.001>
- Yuen, K. F., Bin Saidi, M. S., Bai, X., & Wang, X. (2021). Cruise transport service usage post COVID-19: The health belief model application. *Transport Policy*, 111, 185-196. <https://doi.org/10.1016/j.tranpol.2021.08.002>
- Zhang, Y., Liu, C., Luo, S., Xie, Y., Liu, F., Li, X., & Zhou, Z. (2019). Factors Influencing Patients' Intentions to Use Diabetes Management Apps Based on an Extended Unified Theory of Acceptance and Use of Technology Model: Web-Based Survey. *Journal of Medical Internet Research*, 21(8). <https://doi.org/10.2196/15023>
- Zhao, Y., Ni, Q., & Zhou, R. (2018). What factors influence the mobile health service adoption? A meta-analysis and the moderating role of age. *International Journal of Information Management*, 43, 342-350. <https://doi.org/10.1016/j.ijinfomgt.2017.08.006>