

The Indoor Environmental Quality Improving and Energy Saving Potential of Phase-Change Material Integrated Facades for High-Rise Office Buildings in Shanghai

Qian Jin[†]

College of Architecture and Urban Planning, Tongji University, Shanghai 200092, China

Abstract

The conflict between indoor environmental quality and energy consumption has become an unneglectable problem for high-rise office buildings, where occupants' productivity is highly affected by their working environment. An effective façade, therefore, should play the role of an active building skin by adapting to the ever-changing external environment and internal requirements. This paper explores the energy-saving and indoor environment-improving potential of a phase-change material (PCM) integrated façade. Building performance simulations, combined with parametric study and sensitivity analysis, are adopted in this research. The result quantifies the potential of a PCM-integrated façade with different configurations and PCM properties, taking as an example a south-oriented typical office room in Shanghai. It is found that a melting temperature of around 22°C for the PCM layer is optimal. Compared to a conventional façade, a PCM-integrated façade effectively reduces total energy use, peak heating/cooling load, and operative temperature fluctuation during the periods of May-July and November-December.

Keywords: Phase change material, Façade, Office building, Indoor environmental quality, Energy demand

1. Introduction

The building sector is a huge energy-consuming sector among all sectors in China. The energy consumption in buildings takes 30% of the total national energy consumption, and carbon emissions from buildings reaches above 20% of the total. In order to follow the global trend of energy development, the Chinese Government has set a target that 50% of the newly-built buildings should meet one of a number of global green-building standards by 2020 (CPC Central Committee and State Council of the People's Republic of China, 2014). One feasible way to achieve this target is to encourage development and application of novel construction materials and systems, as raised in China's 13th Five Year Plan for Housing and Urban Construction Planning (Ministry of Housing and Urban Construction of the People's Republic of China, 2016). High-rise commercial buildings that usually combine high land values, sustainability targets, occupant benefits, and desire to adopt novel technologies, offer great potential for architectural design. Due to various reasons such as outdoor air quality and stability of structure, many high-rise commercial buildings completely rely on mechanical HVAC systems to adjust the indoor environment.

On the other hand, indoor environmental quality has gained more and more attention because of its significant influence on occupants' health and productivity (Fisk, 2000), and hence embedded with high social and financial values (Jin et al., 2012). The more stringent demand for indoor environmental quality, and the fact that it largely relies on mechanical HVAC systems, lead to increased energy demand.

The building envelope is an interface between the external and internal environment. Ideally, it should play the role of moderating the indoor environment by selectively transmitting or blocking desirable or undesirable outdoor environmental resources, in order to balance the need for comfort and energy demand. Conventional facade materials with static properties usually fail to fully respond to the external environment; therefore, novel materials and technologies need to be considered.

Phase-change materials (PCMs) are latent heat/cold-storing materials that reversibly change their state in response to a change in external environmental conditions. Most PCMs are temperature-dependent (Ritter, 2002). As illustrated in Fig. 1, heat is absorbed as temperature rises (stage a→b). When reaching its melting temperature, the phase change starts, accompanied by absorbing a substantial amount of heat to break chemical bonds (Baetens et al., 2010), while the temperature is maintained until phase change is completed (stage b→c). When temperature falls, the heat previously absorbed is released as the material

[†]Corresponding author: Qian Jin
Tel: +86-21-65980608, Fax: +86-21-65986707
E-mail: qjin@tongji.edu.cn

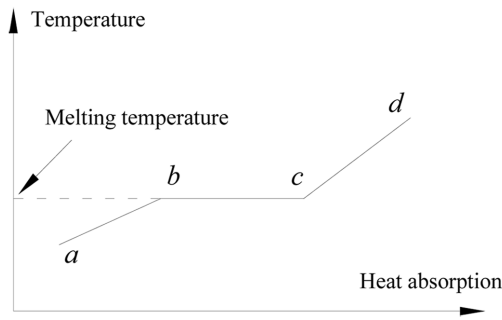

Figure 1. Illustration of PCM working mechanics.

changes its phase back (stage c→b) to reform bonds. PCMs can be grouped into organic, inorganic, and eutectic categories. Organic PCMs are further divided into paraffins and non-paraffins, such as fatty acids. They exhibit no supercooling and phase segregation, but they are flammable and may be toxic during combustion. Inorganic PCMs for building applications mainly consist of hydrated salts. They have higher latent heat storage and thermal conductivity, with a lower cost compared to organic PCMs. Eutectic mixtures can be tailored to meet specific property requirements by adjusting the components (Kalnas and Jelle, 2015).

Cabeza et al. (2011) suggested three melting temperature ranges for different building applications: (A) up to 21°C for cooling applications, (B) 22~28°C for comfort applications, and (C) 29~60°C for hot water applications. Fig. 2 shows the melting enthalpy and melting temperature for some commonly-used materials. An ideal PCM for facades should have a melting temperature close to human comfort temperature (around 20°C) (Sharma, 2009). Fig. 3 shows the thermal properties of some available PCM products from a manufacturer that could be potentially used for a PCM-integrated façade.

Numerical and experimental studies have investigated the performance of PCM-enhanced building envelopes in reducing peak loads, saving energy, and improving thermal comfort for various building types and climates. Zhang

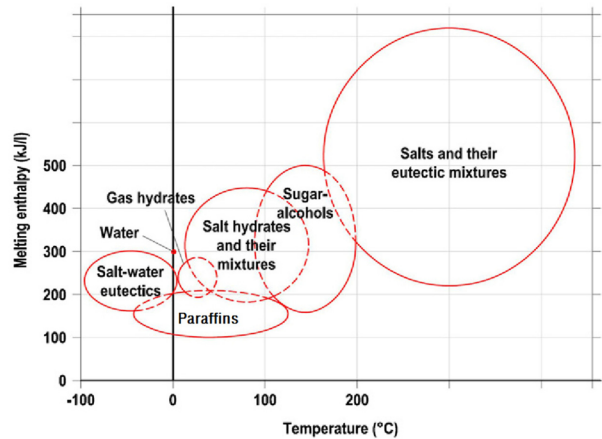

Figure 2. Melting enthalpy vs. phase-change temperature for various materials used in PCMs (Baetens et al., 2010).

et al. (2005) tested a frame wall that integrates a highly crystalline paraffin PCM for residential buildings in a hot and humid summer / cold winter climate in the USA, which reduced wall peak heat fluxes by as much as 38% and cooling load by around 10%. Weinläder et al. (2005) tested and simulated a façade panel consisting of double glazing with PCMs for residential buildings in Würzburg, Germany, and found that heat losses in south-oriented facades could be 30% less, and solar heat gains were also reduced by about 50%, which reduces peak cooling loads during the day. Ascione et al. (2014) studied the effect, during the cooling season, of the addition of PCM plaster on an exterior office building envelope in different Mediterranean climates. For Ankara, Turkey (semi-arid climate), with a melting temperature of 29°C, the cooling energy demand was reduced by around 7.2%, compared to 3.0% in Seville, Spain and Naples, Italy (hot/subtropical Mediterranean climates). Lv et al. (2006) compared the performance of PCM-integrated gypsum board with conventional gypsum board in winter, in test chambers located in southeast China. Results showed that indoor temperature fluctuation could be alleviated by 1.15°C. Kuznik et al. (2011) monitored

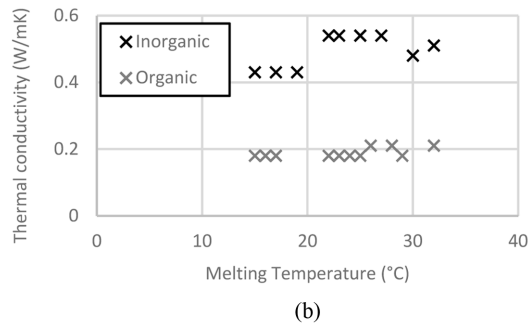
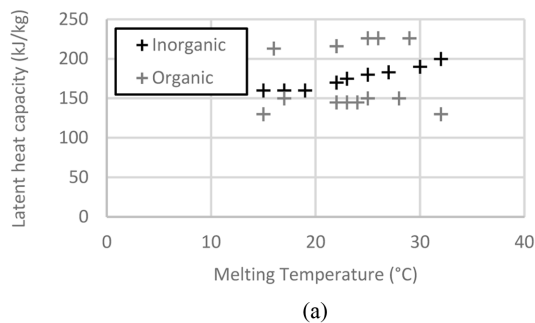

Figure 3. (a) Latent heat capacity vs. melting temperature (b) thermal conductivity vs. melting temperature of commercially available PCM products from a manufacturer (Phase Change Material Products Ltd., 2016).

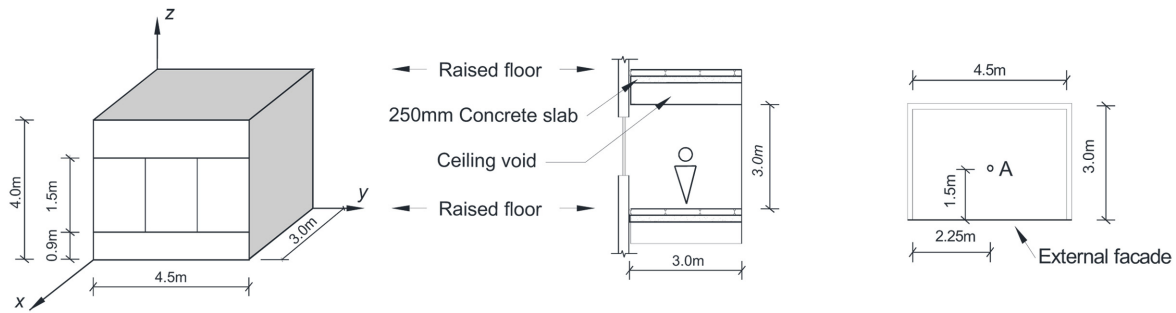

Figure 4. Cellular office room model.

two joint offices with identical geometries located in Lyon, France, one equipped with PCM wallboard in partitions and ceilings and one without. They adopted as their measurement tool the number of hours for which the globe temperature went above 29°C as an indicator of comfort. The difference between the room with PCM and the room without is about 98 h during the tested period from February to December. These studies show that PCM-enhanced building envelope could generally reduce energy demand and while improving indoor thermal comfort, and that the magnitude of improvement significantly depends on the design parameters such as climate, building type, orientation, and specific PCM material properties and building envelope construction.

In this work, the application potential of PCM in façades for high-rise office buildings in the cold winter and hot summer zone of China is studied. A numerical model of a cellular office room in Shanghai is constructed using building performance simulation software. Parametric studies are carried out to compare a PCM-integrated façade with conventional façades in terms of energy savings

and indoor thermal comfort, and to identify the optimal melting temperature of PCM for integration into a façade, so as to achieve a good balance between energy consumption and thermal comfort. The effects of other design parameters such as thickness, thermal conductivity, and latent heat capacity of PCM are investigated by means of sensitivity analysis. The results provide a guidance and direction for PCM development and corresponding façade product design.

2. Methodology

2.1. Description of the cellular office model

A model of a cellular office room in Shanghai (Fig. 4) is constructed using EnergyPlus 8.1 (NREL, 2011). This model was adapted from an experimentally validated model of a climatic chamber (Jin and Overend, 2012). The room size is 4 m high \times 4.5 m wide \times 3 m deep. All the internal surfaces are assumed to be adiabatic, apart from the south façade. The assumption of the boundary condition is made according to a typical cellular office room

Table 1. Parameters for building energy simulation

Parameter	value
Metabolic rate (office activity)	1.2 met (CIBSE, 2006)
Work efficiency (office activity)	0 (CIBSE, 2006)
Indoor air velocity	0.15 m/s (Jan ~ Apr, Oct ~ Dec); 0.23 m/s (May ~ Sep) (MOHURD, 2005)
Clothing level	0.7 (May ~ Sep), 0.85 (Jan ~ Apr, Oct ~ Dec) (CIBSE, 2006)
Occupants	2 persons
Lighting Power Density	18 W/m ² (MOHURD, 2005)
Equipment Power Density	13 W/m ² (MOHURD, 2005)
Façade air permeability	5m ³ /hm ² at 50 Pa
Heating set point	20 °C (6am - 10pm weekdays, 13°C set back) (MOHURD, 2005)
Cooling set point	25 °C (6am - 10pm weekdays, 30°C set back) (MOHURD, 2005)
HVAC system	Variable air volume: heating supply temperature 50°C, cooling supply temperature 13°C
Shading system	Exterior horizontal blind with medium reflectivity slats (0.5 reflectivity). Slat angle adjusted to block direct solar radiation
Lighting system	Automated continuous dimming control, illuminance set point 500 lux. Reference points at mid-point room depth (height 0.8 m).

surrounded by similar rooms in a high-rise office building. The external facade is partially glazed (window-to-wall ratio $WWR=40\%$) with double glazing with low-e coating (U -value = $1.8 \text{ W/m}^2\text{K}$, g -value = 0.6 , visible transmittance = 0.4) and a 10cm -wide thermally broken aluminum frame (U -value = $4 \text{ W/m}^2\text{K}$). The room is mechanically ventilated with 2 air changes per hour (ac/h). Other parameters used in the building energy simulation are summarized in Table 1.

2.2. Configurations of opaque facade panel

The opaque portion of the facade consists of a sandwich panel that has three different configurations (Fig. 5): (1) Reference Configuration (RC) is an insulated concrete wall, i.e., the outer layer is 50 mm thick glass-fiber insulation panel (thermal conductivity = 0.045 W/mK), and the inner layer is 200 mm -thick cellular concrete brick wall (thermal conductivity = 0.2 W/mK); (2) PCM Configuration A (PCM-A) is a PCM-integrated concrete wall without insulation, i.e., the outer layer is 200 mm -thick cellular concrete brick wall (thermal conductivity = 0.2 W/mK), and the inner layer is PCM with thickness $t_A=10 \text{ cm}$; (3) PCM Configuration B (PCM-B) is a PCM-integrated concrete wall with insulation, i.e., a layer of PCM is added to the inner surface of RC, material and geometric properties of PCM are the same as PCM-A. Finishing layers are not considered in this study for they are ignorable for thermal analysis.

2.3. Comparison criteria

The three configurations described in Section 2.2 are compared against two criteria: one is the whole-year primary energy demand, and the other is occupants' thermal comfort. The two criteria are calculated as follows:

(i) Criteria 1: whole year primary energy demand E_{tot} . Sensible heating and cooling energy use E_h and E_c of the office room are first calculated by EnergyPlus 8.1. The fuel factor for electricity f_{EI} is 1.0005 . This is calculated according to GB/T 2589 (ERINDRCC, 2008). The equipment efficiencies in EnergyPlus are assumed to be 100% . The HVAC efficiency for heating η_h is 0.89 and the seasonal energy efficiency ratio (SEER) for cooling is 3.8 (MOHURD, 2005). E_{tot} is therefore calculated according

to Eq (1):

$$E_{tot} = \left(\eta_h \cdot E_h + \frac{E_c}{SEER} \right) \cdot f_{EI} \quad (1)$$

(ii) Criteria 2: occupants' thermal comfort: this is evaluated with the occupancy-weighted annual average predicted percentage of dissatisfaction (PPD) calculated using Eq (2):

$$\text{weighted annual average PPD} = \sum_{h=0}^{h=8760} w_h PPD_h \quad (2)$$

where w_h is the weight of the occupancy in hour h .

2.4. Analysis of different configurations

A parametric study is first carried out to: (1) compare the PCM-integrated facade with a conventional facade, and (2) investigate the effect of melting temperature T_M on the two design criteria. Properties of the PCM layer are determined based on data in Fig. 3, i.e., melting temperature T_M ranges from $15\sim 32^\circ\text{C}$; latent heat capacity HC_l and thermal conductivity λ adopt middle values, i.e., $HC_l=160 \text{ kJ/kg}$, $\lambda=0.35 \text{ W/mK}$. Subsequently, the effects of thickness ($t=10\sim 20 \text{ cm}$), latent heat capacity ($HC_l=100\sim 250 \text{ kJ/kg}$), and thermal conductivity ($\lambda=0.1\sim 0.6 \text{ W/mK}$) of the PCM layer on primary energy demand and thermal comfort are quantified by means of sensitivity analysis.

3. Results and Discussions

3.1. Comparison of the three configurations

Fig. 6 compares the three configurations taking into consideration on different melting temperatures for PCM-A and PCM-B. It can be seen that by adding a 10 cm PCM layer to the inner surface of RC, annual total energy demand E_{tot} could be reduced by $5\sim 6\%$ for T_M ranging from $19\sim 22^\circ\text{C}$. Meanwhile, occupant thermal discomfort PPD can be reduced by 2% for T_M ranging from $22\sim 23^\circ\text{C}$. Therefore, the optimal T_M for configuration PCM-B should be around 22°C . Without conventional thermal insulation, PCM-A is capable of providing a marginally better thermal comfort for T_M ranging from $22\sim 23^\circ\text{C}$ and energy can be saved for T_M ranging from $18\sim 24^\circ\text{C}$, but the improvement is limited. PCM-B generally outperforms PCM-

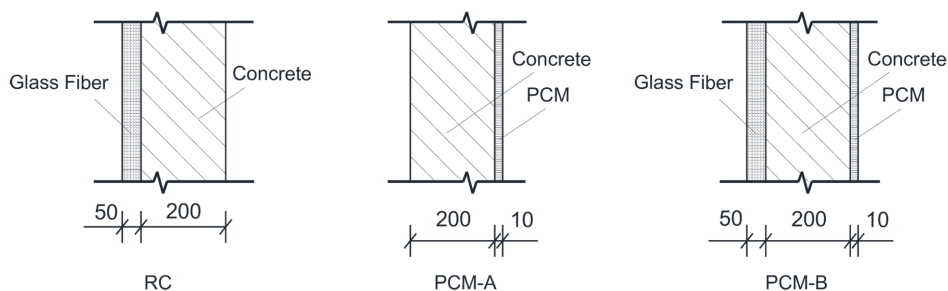

Figure 5. Constructions of the three configurations (Unit: mm).

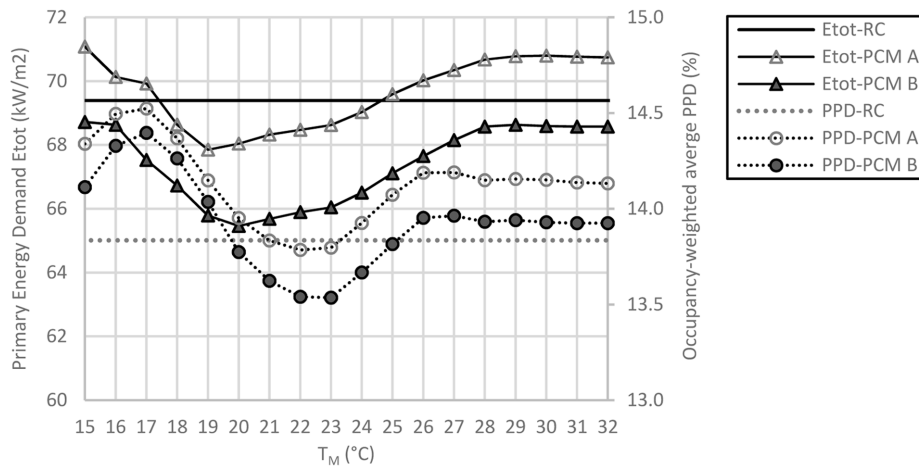

Figure 6. Primary energy demand and occupancy-weighted average PPD vs. T_M for RC, PCM-A, and PCM-B for a south-oriented cellular office room with WWR = 40%.

A, which means that with the current thermal conductivity and thickness of the PCM layer, an additional insulation layer is required to achieve a better performance.

Fig. 7 shows the monthly sensible cooling and heating energy demand for RC and PCM-B ($T_M = 22^\circ\text{C}$). PCM-B saves 12% cooling energy consumption in the period of May-July, because it happens every day that the façade surface temperature fluctuates around 22°C , which allows PCM to effectively absorb undesirable heat and release it at a later stage when the room cools down. This is better illustrated in Fig. 8, which plots the inner surface temperature of the opaque portion of the façade during a typical week in June. Extra heat absorption and release flattens temperature fluctuation and delays temperature increase, and hence stabilizes indoor operative temperature and creates an indoor environment with better thermal comfort. In comparison, the inner surface temperature of the opaque façade from August to October exceeds 22°C most of the time. During this period, the PCM layer either

stays in its melted phase and hence presents no difference from a static insulation layer, or the phase-change process could not be fully completed, resulting a similar indoor thermal environment to RC (Fig. 9). Heating energy demand and from November to December is reduced by 32%, when PCM effectively absorbs heat when the surface temperature is above 22°C , and uses it to warm up the room when the temperature drops. Therefore, although $T_M = 22^\circ\text{C}$ is optimal from a whole-year point of view, it is not effective throughout the year. It mainly contributes to saving of cooling energy in May-July and heating energy in November-December, and to improving thermal comfort during these two periods. By conducting simulations month by month, the monthly optimal T_M can be obtained (Fig. 10). The analysis result shows that 15% more energy could be saved compared to PCM-B; thermal comfort could be improved by 6%, if adaptive T_M for a single construction is possible.

In addition, peak cooling/heating loads and thermal dis-

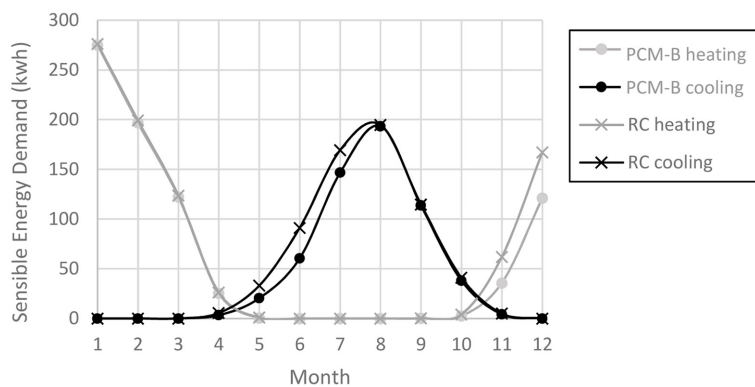

Figure 7. Monthly heating and cooling sensible energy demands of RC and PCM-B ($T_M = 22^\circ\text{C}$) for a south-oriented cellular office room with WWR = 40%.

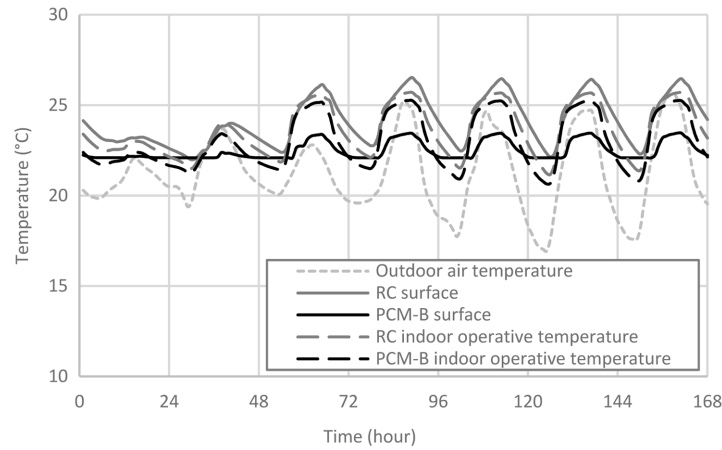

Figure 8. Comparison of the façade inner surface temperature and indoor operative temperature of RC and PCM-B ($T_M=22^{\circ}\text{C}$) for a south-oriented cellular office room with WWR = 40% from June 3-9.

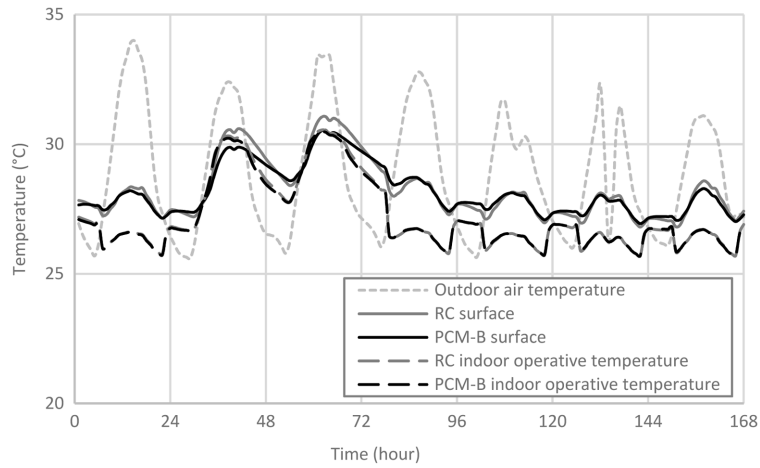

Figure 9. Comparison of the façade inner surface temperature and indoor operative temperature of RC and PCM-B ($T_M=22^{\circ}\text{C}$) for a south-oriented cellular office room with WWR = 40% in Aug 4-10.

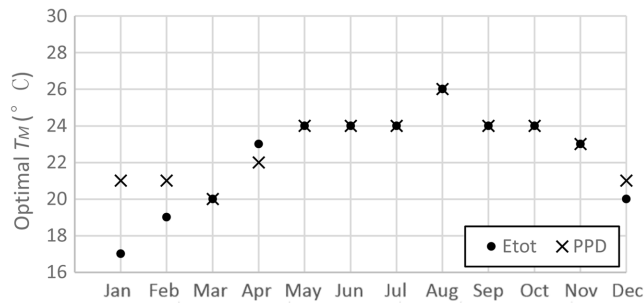

Figure 10. Monthly optimal T_M in terms of E_{tot} and PPD.

comfort are also reduced for the periods of May-July and November-December, respectively. For example, Fig. 11 compares the hourly heating load and hourly PPD for RC and PCM-B during a typical week in December, when the

peak heating load can be reduced by around 20% with PCM-B, while the indoor operative temperature still stays marginally higher than RC.

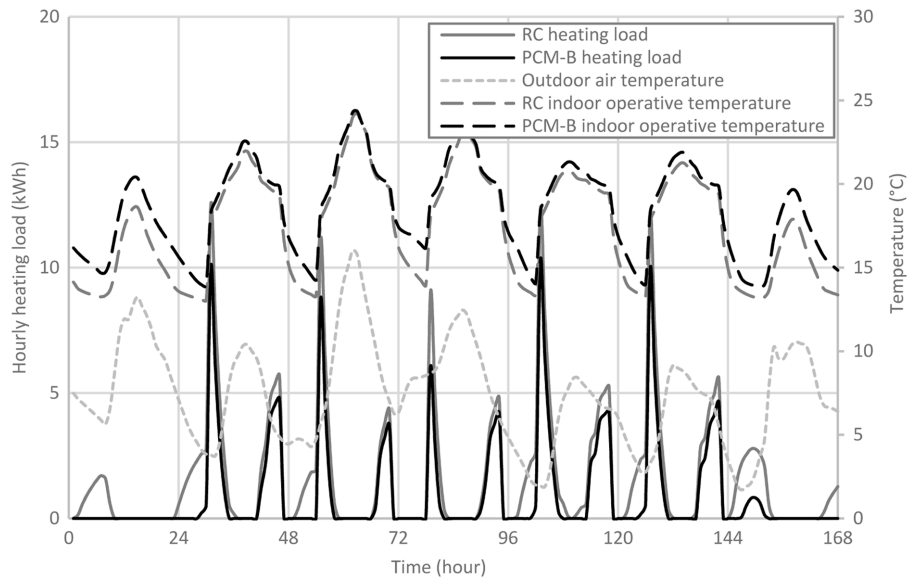

Figure 11. Hourly heating load and indoor operative temperature of RC and PCM-B ($T_M = 22^\circ\text{C}$) for a south-oriented cellular office room with $\text{WWR} = 40\%$ in Dec 3-9.

3.2. Sensitivity analysis result

Figs. 12 and 13 show the sensitivity of thickness and thermal conductivity of the PCM layer to primary energy demand and thermal discomfort. The optimal T_M keeps at around 22°C for different thicknesses and thermal conductivities. By increasing the thickness of PCM layer of PCM-B from 10 cm to 20 cm, total primary energy saving reaches 6%, and thermal discomfort reduces by 3% at optimal T_M compared to RC. Change of thermal conductivity is less affecting for E_{tot} - the maximum difference resulting from $\lambda = 0.1\text{--}0.6 \text{ W/mK}$ is only 1%. However, a lower thermal conductivity is desirable from the perspective of obtaining higher thermal comfort. In particular, a decrease in thermal conductivity from 0.35 to 0.1 W/mK

is equivalent to increasing the thickness of the PCM layer from 10 cm to 15 cm. A similar study has also been done for PCM-A, and results show that the sensitivity to thickness and thermal conductivity is rather small (4% difference in E_{tot} and 2.6% difference in PPD for $t = 10\text{--}20 \text{ cm}$; sensitivity to thermal conductivity is negligible).

Latent heat capacity (HC_l) is also an important property of PCM. Generally, a higher latent heat capacity is desirable. In some cases, increasing PCM layer thickness and using a PCM with higher latent heat capacity might be two alternative choices that could reach the same design objective. For example, for PCM-B with $\lambda = 0.35 \text{ W/mK}$ and $T_M = 22^\circ\text{C}$, either increasing t from 15 to 20 cm while using a PCM with $HC_l = 160 \text{ kJ/kg}$ or increasing $HC_l =$

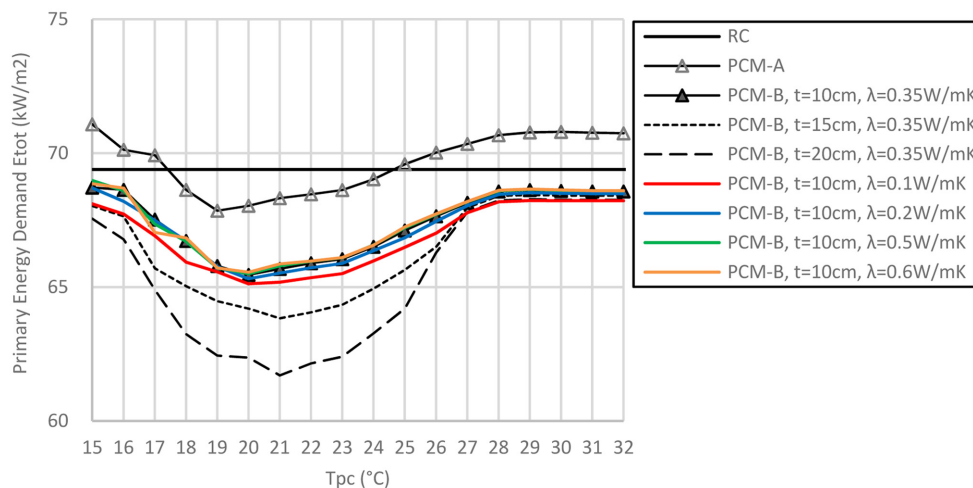

Figure 12. Sensitivity of thickness and thermal conductivity of PCM layer to total energy demand.

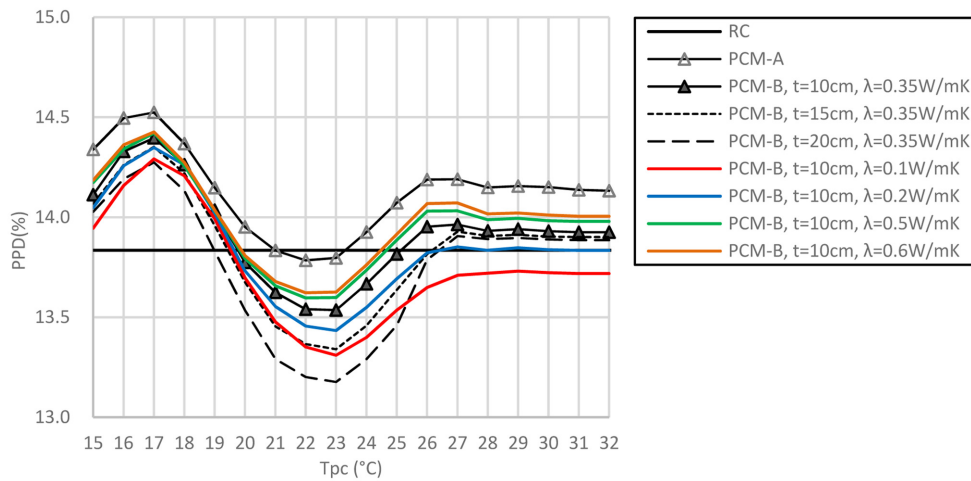

Figure 13. Sensitivity of thickness and thermal conductivity of PCM layer to thermal discomfort.

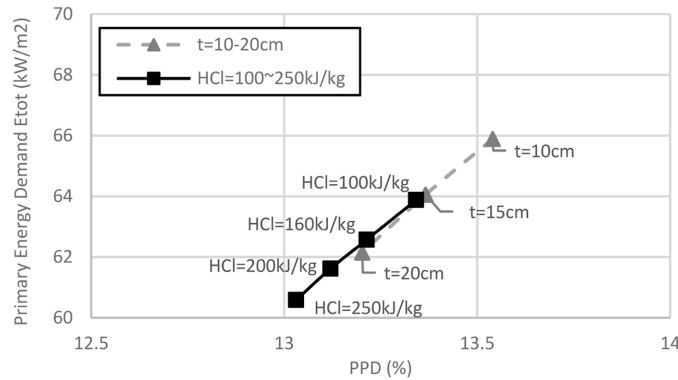

Figure 14. E_{tot} vs. PPD for PCM-B with (a) $t = 10\sim 15$ cm and $LHC = 160$ kJ/kg, and (b) $t = 10$ cm and $LHC = 100\sim 250$ kJ/kg ($\lambda = 0.35$ W/mK and $T_M = 22^\circ\text{C}$).

from 100 to 160 kJ/kg while keeping $t = 10$ cm achieves approximately the same improvement in energy saving and thermal comfort (Fig. 14). However, it should be noted that the range of H_{C_i} and t could be limited by material type, manufacture and construction requirements, so these two options are not always interchangeable.

4. Conclusions

In this paper, the potential of having PCM integrated in the opaque portion of the façade for an office building located in the hot / summer cold winter zone in China is investigated, using a south-oriented cellular office room model in Shanghai as an example. Two configurations of PCM-integrated façades are compared with a conventional façade, and the improvements in energy saving and thermal comfort are quantified. The melting temperature is found to be around 22°C to achieve an optimal balance between whole-year primary energy consumption and thermal comfort for occupants. It is also discovered that with a single

melting temperature, it is not possible for PCM to work effectively throughout the year. In this case, the periods of May to July and November to December see better performance of a PCM-integrated façade compared to a conventional façade, i.e., the former requires less energy to keep a better indoor thermal environment with less operative temperature fluctuation and reduces peak heating/cooling load. However, little difference is observed for other periods of the year. If the melting temperature could be adaptive, a considerable amount of energy could be further saved and thermal comfort improved. This could be a future research direction for PCM development. Results also show that, in order to achieve the same performance objective, increasing PCM thickness could be an alternative to selecting a PCM with lower thermal conductivity or higher latent heat capacity within a specific range.

Acknowledgements

The author would like to acknowledge the financial sup-

port of the National Natural Science Foundation of China (Grant No. 51408427) and the Fundamental Research Funds for the Central Universities of China (Grant No. 2014KJ063).

References

- Ascione, F., Bianco, N., De Masi, R.F., de' Rossi, F., and Vanoli, G.P. (2014). Energy refurbishment of existing buildings through the use of phase change materials: energy savings and indoor comfort in the cooling season. *Applied Energy*, 113, pp. 990~1007.
- Baetens, R., Jelle, B.P., and Gustavsen, A. (2010). Phase change materials for building applications: a state-of-the-art review." *Energy and Buildings*, 42, pp. 1361~1368.
- Cabeza, L.F., Castellon, C., Nogues, M., Medrano, M., Lepers, R., and Zubillaga, O. (2007). Use of microencapsulated PCM in concrete walls for energy savings. *Energy and Buildings*, 39, pp. 113~119.
- Cabeza, L.F., Castell, A., Barreneche, C., Gracia, A., and de Fernandez A.I. (2011). Materials used as PCM in thermal energy storage in buildings: a review. *Renewable and Sustainable Energy Reviews*, 15, pp 1675~1695.
- CIBSE (Chartered Institution of Building Services Engineers). (2006). *CIBSE Guide A: Environmental design*, 7th ed. Page Bros. (Norwich) Ltd, Norwich, UK.
- CPC Central Committee and State Council of the People's Republic of China. (2014). National new urbanization rules (2014-2020) [No. (2014) 31]. (In Chinese)
- Deb, K., Pratap, A., Agarwal, S., and Meyarivan, T. (2002). A fast and elitist multiobjective genetic algorithm: NSGA II. *IEEE Transactions on Evolutionary Computation*, 6(2), pp. 182~197.
- Energy Research Institute of National Development and Reform Commission of China (ERINDRCC). (2008). General principles for calculation of total production energy consumption (GB/T 2589-2008). China.
- Fisk, W.J. (2000) Review of health and productivity gains from better IEQ. *Proc. Healthy Buildings*. Espoo, Finland: Helsinki University of Technology, pp. 23~34.
- Jin, Q. and Overend, M. (2012). Façade renovation for a public building based on a whole-life value approach. *Proc. Building Simulation and Optimisation Conference*, Loughborough, UK, pp. 378~385.
- Jin, Q., Overend, M., and Thompson, P. (2012). Towards productivity indicators for performance-based facade design in commercial buildings. *Building and Environment*, 57, pp. 271~281.
- Kalnas, S.E. and Jelle, B.P. (2015). Phase change materials and products for building applications: A state-of-the-art review and future research opportunities. *Energy and Buildings*, 94, pp. 150~176.
- Kuznik, F., Virgone, J., and Johannes, K. (2011). In-situ study of thermal comfort enhancement in a renovated building equipped with phase change material wallboard. *Renewable Energy*, 36, pp. 1458~1462.
- Lv, S., Zhu, N., and Feng, G. (2006). Impact of phase change wall room on indoor thermal environment in winter. *Energy and Buildings*, 38, pp. 18~24.
- Ministry of housing and urban construction of the People's Republic of China. (2016). The 13th Five Year Plan for Housing and Urban Construction Planning. (In Chinese).
- MOHURD (Ministry of Housing and Urban-Rural Development of China). (2005). Design Standard for Energy Efficiency of Public Buildings GB50189-2005.China.
- MATLAB Release. (2013). The MathWorks, Inc., Natick, Massachusetts, United States.
- NREL (National Renewable Energy Laboratory). (2011). *EnergyPlus8.1*, California, USA.
- Phase Change Material Products Ltd. (2016). www.pcmproducts.net. (accessed on 3.3.2016).
- Ritter, A. (2002). *Smart Materials in Architecture, Interior Architecture and Design*, 1st ed. USA: Birkhäuser Architecture.
- Weinläder, H., Beck, A., and Fricke, J. (2005). PCM-facade-panel for daylighting and room heating. *Solar Energy*, 78 (2), pp. 177~186.
- Zhang, M., Medina, M. A., and King, J. B. (2005). Development of a thermally enhanced frame wall with phase-change materials for on-peak air conditioning demand reduction and energy savings in residential buildings. *International Journal of Energy Research*, 29(9), pp. 795~809.