

Dynamic analysis of ACTIVE MOUNT using viscoelastic-elastoplastic material model

Taeyun Park* and Wonuk Jung
PyungHwa Industrial Co., LTD, Daegu, Korea

Received 07 October 2016; revised 07 December 2016; accepted 27 December 2016

Abstract: The engine mount of a car subjected to a pre-load related to the weight of the engine, and acts to insulate the vibration coming from the engine by moving on large or small displacement depending on the driving condition of the car. The vibration insulation of the engine mount is an effect obtained by dissipating the mechanical energy into heat by the viscosity characteristic of the rubber and the microscopic behavior of the additive carbon black. Therefore, dynamic stiffness from the intrinsic properties of rubber filled with carbon black at the design stage is an important design consideration. In this paper, we introduced a hyper-elastic, visco-elastic and elasto-plastic model to predict the dynamic characteristics of rubber, and developed a fitting program to determine the material model parameters using MATLAB. The dynamic characteristics analysis of the rubber insulator of the ACTIVE MOUNT was carried out by using MSC.MARC nonlinear structural analysis software, which provides the dynamic characteristics material model. The analysis results were compared with the dynamic characteristics test results of the rubber insulator, which is one of the active mount components, and the analysis results were confirmed to be valid.

Key Words: *dynamic modulus, Elasto-plasticity, MOUNT, Payne effect, Rubber, Visco-elasticity*

1. INTRODUCTION

The engine mount of a car subjected to a pre-load related to the weight of the engine, and acts to insulate the vibration coming from the engine by moving on large or small displacement depending on the driving condition of the car. The vibration insulation of the engine mount is an effect obtained by dissipating the mechanical energy into heat by the viscosity characteristic of the rubber and the microscopic behavior of the additive carbon black. Therefore, dynamic stiffness from the intrinsic properties of rubber filled with carbon black at the design stage is

*Corresponding Author.
E-mail address: *parktaeyun@ph.co.kr*

an important design consideration. In this paper, hyper-elastic, visco-elastic and elasto- plastic material models are introduced and the parameters of the material models are determined by fitting the test results. And the finite element analysis was performed using the determined material model parameters. The analysis results were compared with the dynamic characteristics test results of the rubber insulator, which is one of the active mount components, and the analysis results were confirmed to be valid.

2. Dynamic Characteristics of Carbon Black Filled Rubber

The dynamic properties of carbon-black filled rubber are affected by factors such as frequency, excitation amplitude, preload, and temperature, and can be expressed by damping and dynamic stiffness coefficients. General natural rubber has a frequency dependency that tends to increase as the frequency increases. The stress-strain diagram in the condition of harmonics appears as an elliptical shape and can be expressed as a linear viscoelastic model. The carbon black filled rubber shows a tendency that the dynamic stiffness decreases as the amplitude of the vibration increases under the condition of harmonization by rearrangement and breaking of the carbon black structure. This tendency to decrease the dynamic stiffness is not affected by the frequency change, and the frequency dependency and the amplitude dependency are independent of each other.

3. DYNAMIC CHARACTERISTIC MATERIAL MODEL

The material characteristics model of the dynamic behavior is represented by the hyper- elastic model showing the large deformation behavior, the visco-elastic model showing the viscous properties of the rubber, and the elasto-plastic model showing the microscopic behavior of the carbon black.

The hyper-elastic model used the Yeoh model, which is a representative strain energy density function.

$$U = \sum_{i=1}^3 C_{i0} (I_1 - 3)^i \quad (1)$$

Equation (1) is the Yeoh model with fully uncompressed behavior, and I_1 is the first strain invariant. As shown in Figure.1, the viscoelastic model is the generalized Maxwell model with one hyper-elastic model (E_{∞}) and several set elements connected in series with spring (E) and dashpot (η) elements in parallel.

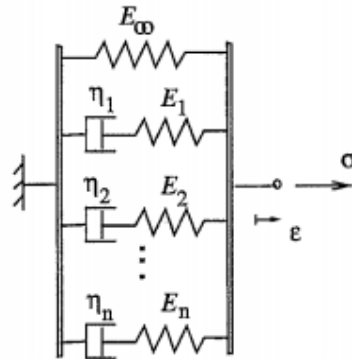

Figure 1. The generalized Maxwell model

$$E_R(t) = E_\infty + \sum_{j=1}^n E_j e^{-t/t_{rj}} \tag{2}$$

$$E^*(\omega) = E_\infty + \sum_{j=1}^n E_j \frac{i\omega t_{rj}}{1 + i\omega t_{rj}} \tag{3}$$

The generalized Maxwell model can be expressed as the prony series in the form of a series as shown in equation (2). Equation (2) can be expressed as a complex form as shown in Equation (3) through Fourier transform. Where t_r is the value of η / E .

The elasto-plastic model was a multi-linear kinematic hardening model as shown in Figure 2.

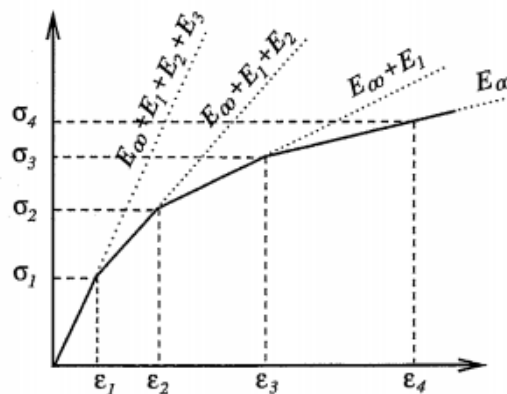

Figure 2. The multi-linear kinematic hardening model

As shown in Figure 3, the dynamic characteristics material model of the carbon black filled rubber is shown in the form of the above three models in parallel in order to show frequency dependency and amplitude dependency.

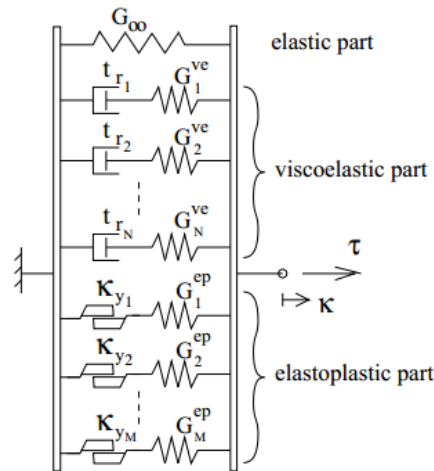

Figure 3. The one-dimensional material model combining visco-elasticity and elastoplasticity

4. DEVELOPMENT OF FITTING PROGRAM

To obtain the material parameters of the material model shown in Figure 3, a program was developed to minimize the error of between the test and the material model. The program was coded using the fmincon function, a multi-dimensional linear search algorithm function of Matlab (MathWorks Inc). Since there are many material parameters to be obtained, we used a method of setting the search range and approaching stepwise in order to find an appropriate solution.

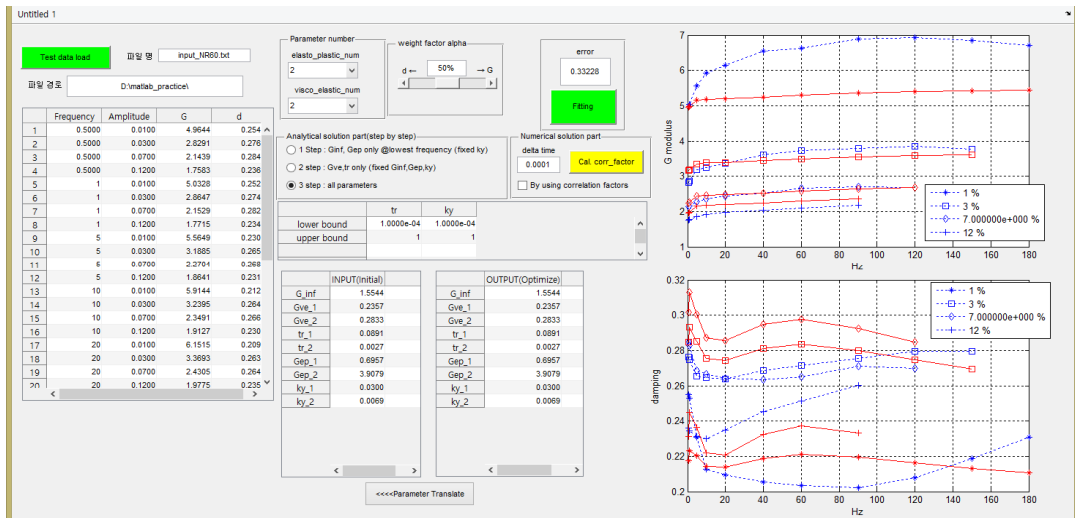

Figure 4. The dynamic characteristic material model fitting program

5. DYNAMIC CHARACTERISTIC ANALYSIS

There is an overlay method proposed by Olsson (2007) for the analysis of rubber dynamic characteristics using the finite element method. This method has the advantage that general commercial analysis software can be used without developing a finite element analysis code for a material model.

However, the calculation is possible only in the time domain, and there is a disadvantage in that the computational time is long due to the large capacity of the model to be calculated because one hyperelastic-viscoelastic element is overlapped with M number of elastoplastic elements as many as the number of material parameters.

Hartley (Hartley, 2012) complements the disadvantages of the Olsson's method by suggesting a method of reducing the number of elasto-plastic finite element model from M to one. He applied a multi-linear kinematic hardening model to reduce the number of finite element model to one. Recently, MSC.MARC software has added a model that can consider the Payne effect in the frequency domain. This software provides a thixotropic model that can exhibit amplitude dependence by modifying the visco-elastic model, and a tribo-elastic model corresponding a multi-linear kinematic hardening model. This software also offers a combination of these two models.

In this paper, we use the combination model of the above two models. The real part, or storage factor, of the complex coefficient of the thixotropic model in the complex plane is:

$$g'(\omega, |\Delta\bar{\epsilon}|) = g_{\infty} + \sum_{k=1}^N \frac{g_k \omega^2 t_{r_k}^2}{\left(1 + d_k \frac{2}{\pi} \omega |\Delta\bar{\epsilon}|\right)^2 + \omega^2 t_{r_k}^2} \quad (4)$$

Where g is the normalized shear modulus divided by the short-term shear modulus. $\Delta\epsilon$ is the strain increment and d_k is the material time parameter related the amplitude dependence.

The loss factor, which is the imaginary part of the complex coefficient, is as follows.

$$g''(\omega, |\Delta\bar{\epsilon}|) = g_{\infty} + \sum_{k=1}^N \frac{g_k \omega^2 t_{r_k}^2}{\left(1 + d_k \frac{2}{\pi} \omega |\Delta\bar{\epsilon}|\right)^2 + \omega^2 t_{r_k}^2} \quad (5)$$

If $d_k = 0$ in the equations (4) and (5), it is the same as the generalized Maxwell model equation (3).

6. DETERMINATION OF MATERIAL PARAMETERS

The uniaxial tensile and biaxial tensile test data were used to fit the Yeoh model to determine model parameters. The test was carried out by Axel, a professional testing laboratory. The test data used for the fitting is a loading curve at five cycles after four cycles of preconditioning for a nominal strain of 100%. The extracted a loading curve was calibrated so that it could be started at the origin, taking into account increased the specimen gauge length due to preconditioning.

The final fitting results are shown in Figure 5 and Table 1.

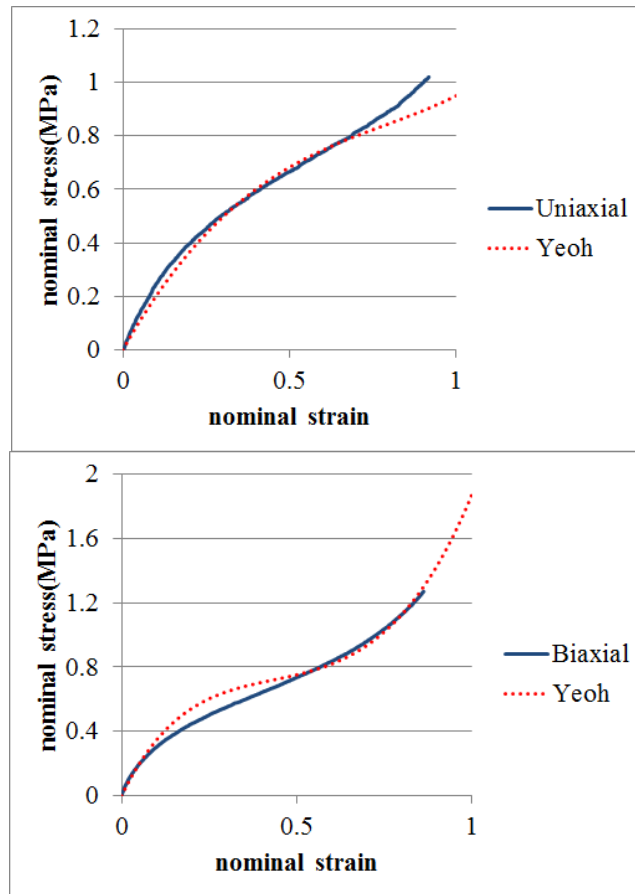

Figure 5. Results of fitting to test data for the Yeoh model

Table 1. Parameters of the Yeoh model

Parameter	C_{10}	C_{20}	C_{30}
[MPa]	0.37166	-0.048026	0.007674

A harmonic test was conducted to determine parameters of the dynamic characteristics material model. It was carried out under the conditions of 1% amplitude and 2% amplitude in the pre-strain 5% tensile state and 0.1 ~ 200Hz.

Model fitting with test data was performed using the dynamic characteristic material model fitting program written in Matlab. The fitting results are shown in Figure 6 and Table 2. The fittings were fitted with an error value of 0.00645, and were graphically confirmed to have been fitted with a similar tendency. In Figure.6, the blue line is the test result and the red line shows the fitted material model.

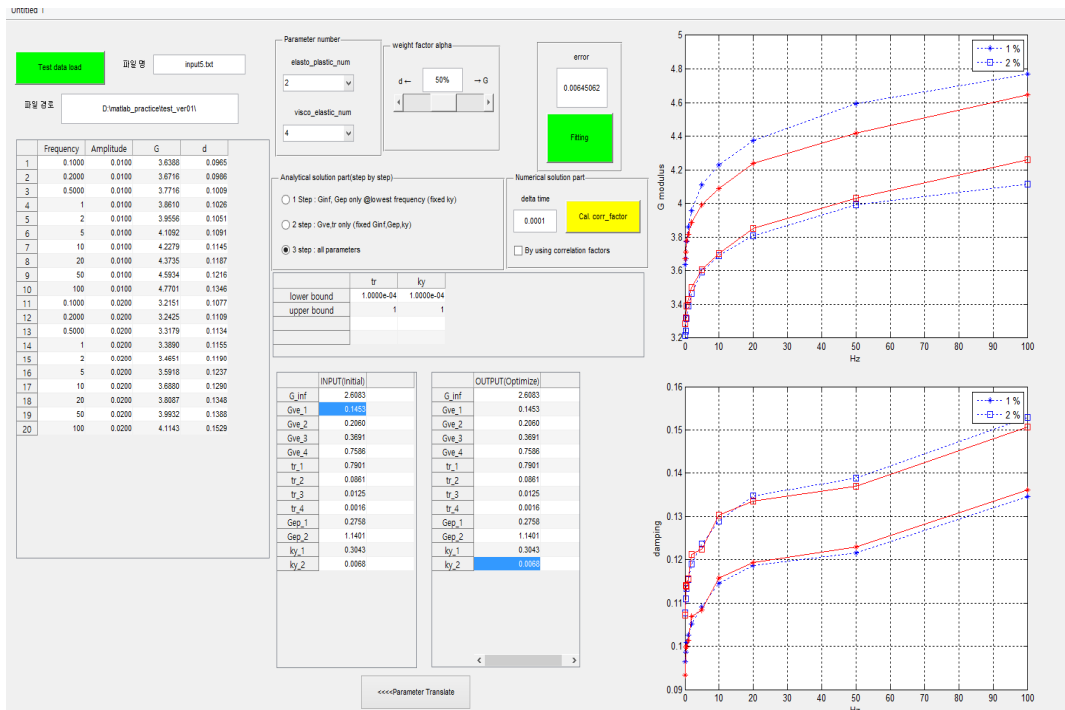

Figure 6. Results of fitting with test data for the dynamic material model

Table 2. Parameters of the dynamic material model

N	G_{∞}	G_N^{ve}	t_{rN}	G_N^{ep}	γ_{yN}	error
1	2.6083	0.1453	0.7901	0.2758	0.3043	0.00645
2		0.2060	0.0861	1.1401	0.0065	
3		0.3691	0.0125			
4		0.7586	0.0016			

7. ACTIVE MOUNT TESTING AND ANALYSIS

The insulator of ACTIVE MOUNT is made of the same rubber material as the specimen. The product test was carried out with a pre-load of 120 kgf and a frequency range of 0.5 to 100 Hz with an excitation amplitude of 0.1, 0.2, 0.5 and 1 mm. The test machine is MTS-831 shown in Figure7. The detailed conditions of the harmonic test are shown in Table 3. In the finite element analysis, first, static analysis was performed with preload 120kgf, then a frequency response analysis was performed by dividing the frequency into a frequency range of 0.5 to 100 Hz by 10 times for an amplitude of 0.1, 0.2, 0.5, and 1 mm.

As shown in Figure 8, only the rubber part was meshed as a tetrahedral element with an average size of 2 mm, and the inner aluminum core part was modeled as Rigid Body Element 2 (RBE2). The analysis program used the MSC.MARC program.



Figure 7. MTS-831 test machine

Table.3 Conditions for steady state harmonic excitation test

Amplitude	Frequencies
0.1mm	0.5, 10, 20, 40, 70, 100 Hz
0.2mm	0.5, 10, 20, 40, 70, 100 Hz
0.5mm	0.5, 10, 20, 40 Hz
1.0mm	0.5, 10, 20, 40 Hz

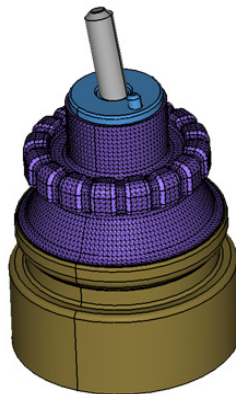
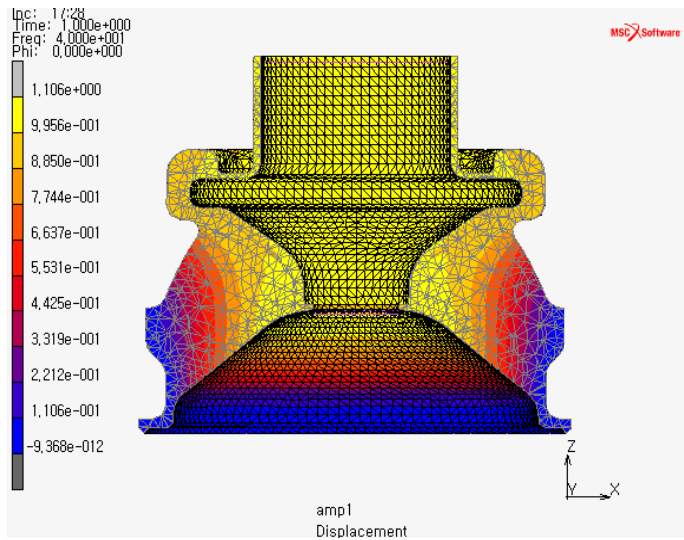

Figure 8. Finite element model

8. ANALYSIS RESULTS

The analysis results are shown as the storage modulus and loss angle as shown in Figure 9.

As shown in Figure 9 (a), the storage modulus results show an error rate of less than 10% compared with the test, and it can be concluded that the tendency of dynamic stiffness changes with frequency. The loss angle results in Figure 9 (b) show some error rates compared with the test. In addition, the decrease in dynamic rigidity due to the amplitude increase of the excitation amplitude between 0.2 mm and 0.5 mm can be confirmed clearly.



(a) Displacement Contour

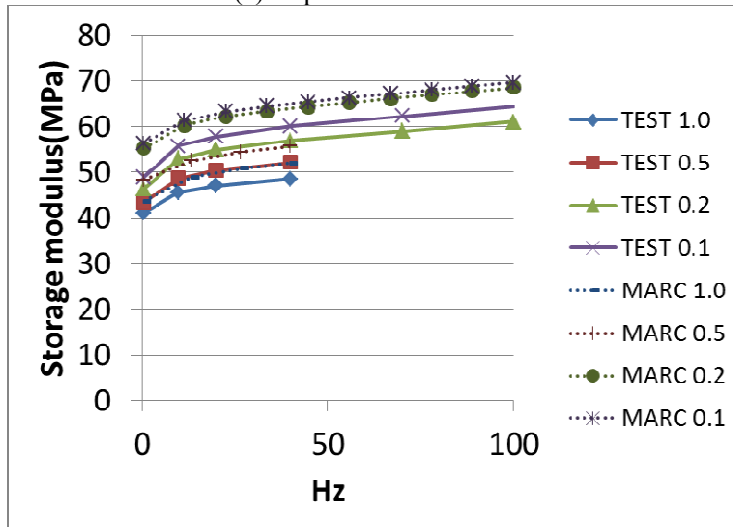

(b) Storage modulus

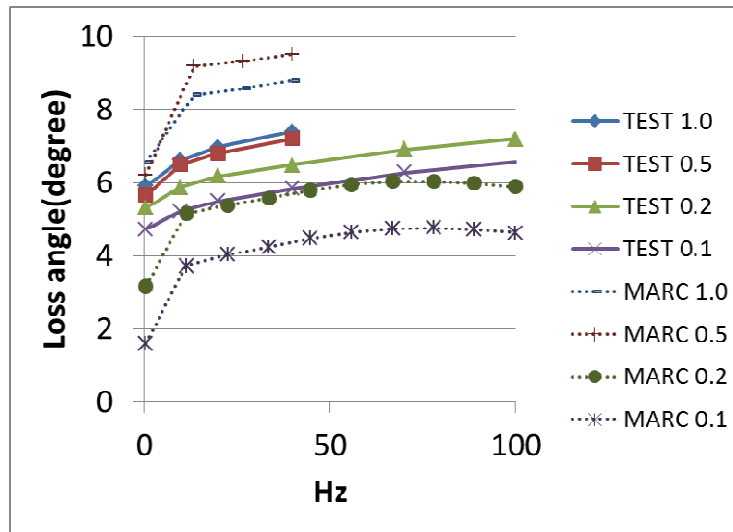

(c) Loss angle

Figure 9. Results of steady state dynamic analysis

9. CONCLUSION

We introduced a hyper-elastic, visco-elastic and elasto-plastic model to predict the dynamic characteristics of rubber, and developed a fitting program to determine the material model parameters using MATLAB.

The dynamic characteristics analysis of the rubber insulator of the ACTIVE MOUNT was carried out by using MSC.MARC nonlinear structural analysis software, which provides the dynamic characteristics material model.

As a result of the analysis, it was confirmed that the prediction of the tendency of the dynamic stiffness is reliable, and the decrease of the dynamic stiffness due to the amplitude increase by the elasto-plastic model was also confirmed.

However, the predicted loss angle is somewhat larger than the test value, and further studies are needed to reduce this error.

ACKNOWLEDGMENT

This research was supported by the Ministry of Trade, Industry & Energy (MOTIE), Korea Institute for Advancement of Technology (KIAT) through the Encouragement Program for The Industries of Economic Cooperation Region.

REFERENCES

- ABAQUS user manual ver. 6.13. Dassault Systèmes Simulia Corp.
- MSC.MARC user manual ver. 2015. MSC Software Corp.
- Matlab user manual ver.2012, Math Works Inc.
- Anders K. Olsson (2007). *Finite element procedures in modelling the dynamic properties of rubber*. (PhD Thesis), LUND University, Sweden.
- Christopher Robert Hartley and Jaehwan Choi (2012). Finite element overlay technique for predicting the payne effect in a filled-rubber cab mount, *SAE International Passeng. Cars – Mech Sys.* , Vol. 5, Issue 1.
- Per-Erik Austrell (1997). *Modeling of elasticity and damping for filled elastomers*.(PhD Thesis) , LUND University, Sweden.
- Fredrik Karlsson and Anders Persson (2003). *Modelling non-linear dynamics of rubber bushings - parameter identification and validation*.(Master's Dissertation) , LUND University, Sweden.
- Shin-Bog Lee (2013). Development of dynamic modeling of rubber mount, *The Korean Society for Noise and Vibration Engineering*, 87-91.
- Kim, Y. S. (2014). *Mechanics of plastic deformation*, Sigma Press, 151-164.
- Jakel R.(2010). *Analysis of hyperelastic materials with MECHANICA -theory and application examples*, Presentation for the 2nd SAXIM