

# Relationship between the Applied Torque and CCT to obtain the Same Corrosion Resistance for the Plate and Cylindrical Shape Stainless Steels

Hyun Young Chang<sup>1</sup>, Ki Tae Kim<sup>2</sup>, Nam In Kim<sup>2</sup>, and Young Sik Kim<sup>2,†</sup>

<sup>1</sup>Power Engineering Research Institute, KEPCO Engineering & Construction Company, 269, Hyeoksin-ro, Gimcheon, Gyeongbuk, 39660, Korea

<sup>2</sup>School of Materials Science and Engineering, Materials Research Center for Energy and Green Technology, Andong National University, 1375 Gyeongdong-ro, Andong, Gyeongbuk, 36729, Korea

(Received January 26, 2016; Revised April 08, 2016; Accepted April 08, 2016)

Many industries need the universal standard or technique to obtain the identical CCT regardless of specimen geometries. This study aimed to determine an appropriate applied torque to the cylindrical specimen defining the apparatus and the procedure to measure the temperature of initiating crevice corrosion in tubular shape products such as pipes, tubes and round rods etc; the test method also proved applicable to the plate type specimen. A series of experiments for CCT measurements with the plate type and cylindrical stainless steel specimens of various diameters with different microstructures (austenitic and duplex) and PRENs were conducted to determine the relationship among geometries on CCT. Thus, the apparatus that could measure the CCT of stainless steels with both plate and cylindrical geometries was newly designed. The use of the apparatus facilitated the same CCT value for both geometries only if the specimens were made of the same alloy. The applied torque can be calculated for various diameters of the cylindrical specimens using the following relation; Applied torque,  $Nm = -0.0012D^2 + 0.019D + 2.4463$  ( $D$ ; the diameter of cylindrical specimen, mm). However, upwards of 35 mm diameter cylindrical specimens require 1.58Nm, which is the same torque for the plate type specimen; in addition, this test method cannot be used for cylindrical specimens of less than 15 mm diameter.

**Keywords :** stainless steel, crevice corrosion temperature (CCT), pitting resistance equivalent number (PREN), applied torque, plate, cylindrical shape

## 1. Introduction

Various dimensions of pipes and tubes have been used in industries including nuclear power plants, thermal power plants, desalination plants, oil refining facilities and chemical plants etc. Materials evaluation for these pipes, tubes and fittings makes all the difference to safety and life cycles in these industrial facilities.

There are numerous standards that specify test methods and corrosion resistance for pitting and crevice corrosion<sup>1-12</sup>. Many of them address the corrosion rate or Critical Pitting Temperature (CPT) or Critical Crevice Corrosion Temperature (CCT) of plate type specimens but they are not concerned with other geometries and relations of corrosion resistance between geometries.

It demands that initiation temperature of crevice corrosion be measured in cylindrical crevice geometries for

high corrosion resistant alloys including from traditional stainless steels to super stainless steels.

This standard provides the test method that measures crevice corrosion resistance in crevice geometries such as tube/tube sheet of heat exchangers and pipes/pipe supports, flange/couplings, bolts/nuts etc. in industrial facilities. It can be used as a guideline which offers the criterion for materials selection of such components.

Most of crevice corrosion tests have been performed conforming to some standards<sup>1,2,4-7,9,10</sup>, but these test methods use a flat geometry of an artificial crevice which shows different crevice corrosion temperatures to those of cylindrical crevice geometry. These results of the test have brought about a lot of controversies in related industries.

Therefore, many industries need the universal standard or technique to obtain the identical CCT between plate type and cylindrical type specimens. This work aims to find an appropriate applied torque to the cylindrical specimen and to define the apparatus and the procedure to

<sup>†</sup> Corresponding author: yikim@anu.ac.kr

**Table 1. Chemical composition (wt%) and PRE number of experimental alloys - group 1**

Alloys	Cr	Mo	N	Ni	Mn	C	Si	W	Fe	PRE <sub>30</sub>
S32050	22.8	6.1	0.24	22.6	0.40	0.02	0.30	0.08	Bal.	50.2
D2002	21.1	5.2	0.27	9.0	0.88	0.04	0.97	0.01	Bal.	46.4
D2300	22.1	3.1	0.24	9.4	0.51	0.02	0.48	1.8	Bal.	42.5

$$\text{PRE}_{30} = \%Cr + 3.3 (\%Mo + 0.5 \%W) + 30 \%N$$

**Table 2. Chemical composition (wt%) and PRE number of austenitic stainless steels - group 2**

Alloys	Cr	Mo	N	Ni	Mn	C	Si	Fe	PRE <sub>30</sub>
A1	22.9	0.01	0.36	13.0	0.50	0.02	0.42	Bal.	33.7
A2	23.1	1.04	0.39	14.1	0.47	0.02	0.44	Bal.	38.2
A3	23.1	4.52	0.43	17.5	0.47	0.03	0.44	Bal.	50.9

$$\text{PRE}_{30} = \%Cr + 3.3 (\%Mo + 0.5 \%W) + 30 \%N$$

**Table 3. Chemical composition (wt%) and PRE number of duplex stainless steels - group 3**

Alloys	Cr	Mo	W	Si	Ni	Mn	C	N	Fe	PRE <sub>30</sub>
D1	22.1	3.09	1.8	0.48	9.39	0.51	0.02	0.24	Bal.	42.6
D2	25.8	2.26	0.16	0.48	10.7	0.65	0.03	0.42	Bal.	46
D3	28.5	3.6	0.43	0.71	11.1	0.71	0.08	0.40	Bal.	53

$$\text{PRE}_{30} = \%Cr + 3.3 (\%Mo + 0.5 \%W) + 30 \%N$$

measure the temperature of initiating crevice corrosion in the pipes and tubes having cylindrical crevice geometry in addition to the application of the plate type specimen.

## 2. Experimental Methods

### 2.1 Materials

The specimens used in this study are summarized as 3 groups; (1) Group 1 - PRE 43, 47 and 52 alloys of which chemical compositions are shown in Table 1. The plate type specimen was fabricated in the form of 20 mm x 20 mm x 10 mm(t) with a hole (8 mm dia.) drilled smack-dab in the middle of it. The cylindrical type specimen features 25 mm diameter with 20 mm length. (2) Group 2 - austenitic stainless steels with different PRE numbers. The cylindrical type specimen was machined to 35 mm diameter with 20 mm length. (3) Group 3 - duplex stainless steels with different PRE numbers. The cylindrical type specimen was also machined to 35 mm diameter with 20 mm length.

### 2.2 Design of crevice corrosion test assembly

The apparatus was realized with the method of bolting. The frame of test kit was made of Ti grade 2 and polytetrafluoroethylene (PTFE) crevice former was adjusted according to the diameter of cylindrical specimen.

3D stress analysis was performed for stress distribution on the specimen with ANSYS and COMSOL software. Materials characteristics (Young's modulus, Poisson's ratio etc.) for Ti grade 2 and PTFE were referred to the database of software. It was assumed that the artificial PTFE crevice formers were linear elastic material because when they were plastically deformed, the torques applied would be meaningless. All faces except contact ones in specimen and crevice formers were given free surface boundary condition. The only boundary load was the force in -z direction calculated from the applied torque which was generated from between Ti bolt and nut of outside frame. Fixed constrain condition was given for the lower bottom of the Ti frame whereas spring foundation condition was assumed for the PTFE crevice formers. Contact mesh was applied for the interfaces between specimen and

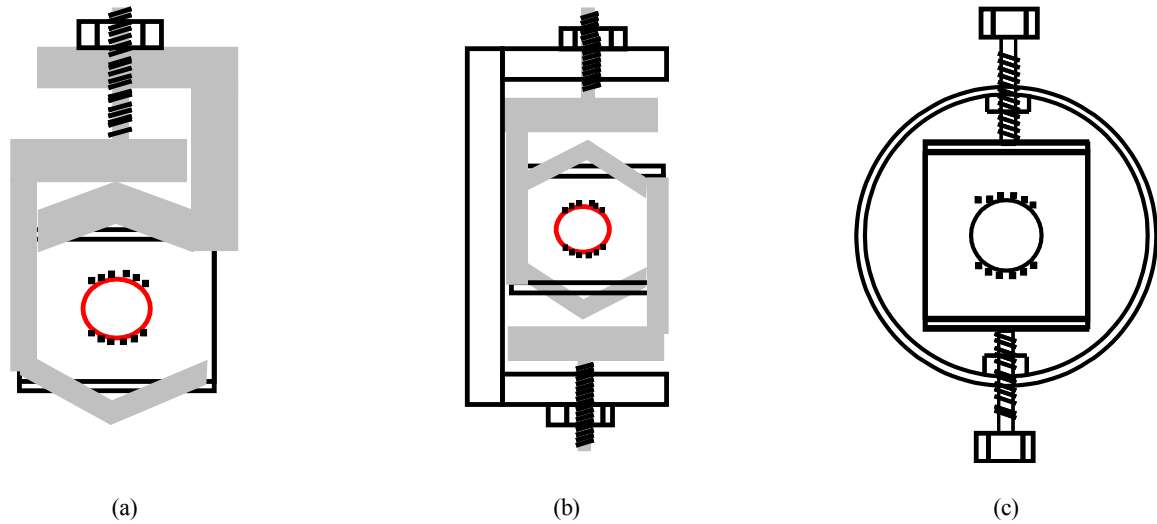

Fig. 1. Candidate designs of the crevice test assembly for a cylindrical specimen.

crevice formers being added friction coefficient from the literatures. Then, mesh was generated optimized to local geometric characteristics. Stationary was chosen as the solver for the contact problem in solid mechanics because it was important to find out the spike in local stress and strain.

### 2.3 CCT measurement

Chloride containing solutions such as ferric chloride and acidified ferric chloride solutions are useful to determine localized corrosion rate. Crevice former is essential to produce crevice corrosion and its dimension shall be modified according to various pipes and tubes. The solution used in this test was one of two solutions that were 6%  $\text{FeCl}_3$  solution and 6%  $\text{FeCl}_3$  solution added with 1% HCl. Artificial crevice formers with a specimen shall be completely immersed in the test cell. Volume of solution shall be at least  $5\text{mL}/\text{cm}^2$  of specimen surface area. Surface condition of specimens may greatly affect test results and therefore, its surface shall be uniformly wet-ground using a SiC paper (# 120) to get the meaningful data. A 24 hour of passivation in air after grinding was performed.

Crevice corrosion temperature which shows initiation of crevice corrosion shall be measured for a specimen from a certain temperature. After 24h of immersion, if there's no initiation of crevice corrosion, then the other specimen was subjected to the test with a  $5\text{ }^\circ\text{C}$  raised from the previous temperature. Test was repeated with the ranks of  $5\text{ }^\circ\text{C}$  raise until crevice corrosion initiates. Every specimen in each temperature was fabricated from the same product or from the identical heat of a raw mate-

rial with the same geometry. The ferric chloride solution used in this test is a strong acidic corrosive medium causing pitting or crevice corrosion in high corrosion resistant alloys. Even though measurement of weight of a specimen before and after test make it possible to show initiation of crevice corrosion, credibility of the results is not so high because the strong test solution may inadvertently corrodes edges of the specimen. The definition of CCT is the temperature in which crevice corrosion initiated. The criterion of initiation was defined as that corrosion reached the depth of 0.025 mm from the bold surface onto which the crevice washer was contacted, with edge attack ignored. The depth was measured using a 3D microscope.

## 3. Results and Discussion

### 3.1 Design of CCT assembly for cylindrical and plate specimen

Two methods using rubber bands and crevice formers in ASTM G48 are useful for measuring the resistance of crevice corrosion of plate type materials<sup>1)</sup>, however, these methods cannot be applied for the cylindrical type products. Even though the crevice corrosion test assembly can be applied that fits the rounded crevice former of rod type materials, but it has the problem that applying uniform torque for the crevice former shows different corrosion resistance between a plate type and a rod type material.

Fig. 1 shows some designs of crevice assemblies suggested testing a cylindrical specimen. Stress distribution analyses have been performed for all of these designs as shown in Fig. 2. It can be shown from this figure that

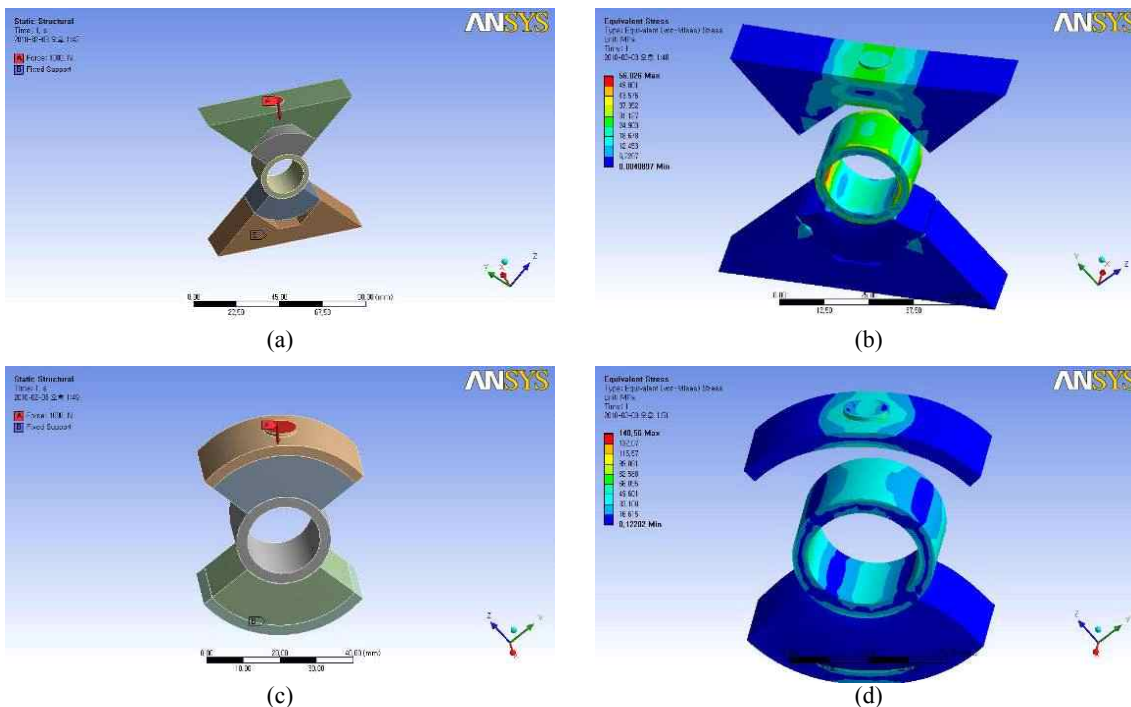

Fig. 2. Results of stress analysis for candidate designs of the crevice test assembly.

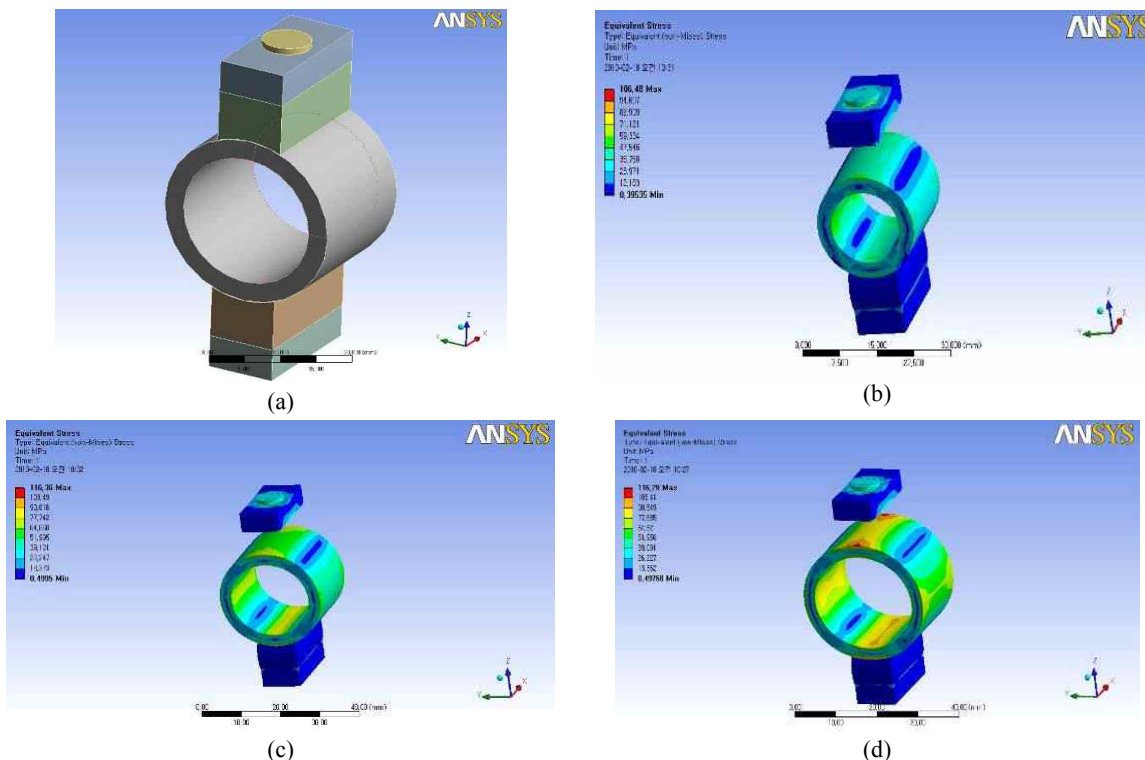

Fig. 3. Results of stress analysis for the finally selected design of the crevice test assembly.

stress distributions are varied according to the methods of applying torque. The most appropriate design was selected from the results of stress analyses for candidate

designs showing the stress distribution in Fig. 3.

The frame of crevice test assembly is made up of titanium grade 2 as shown in Fig. 4 that has high corrosion

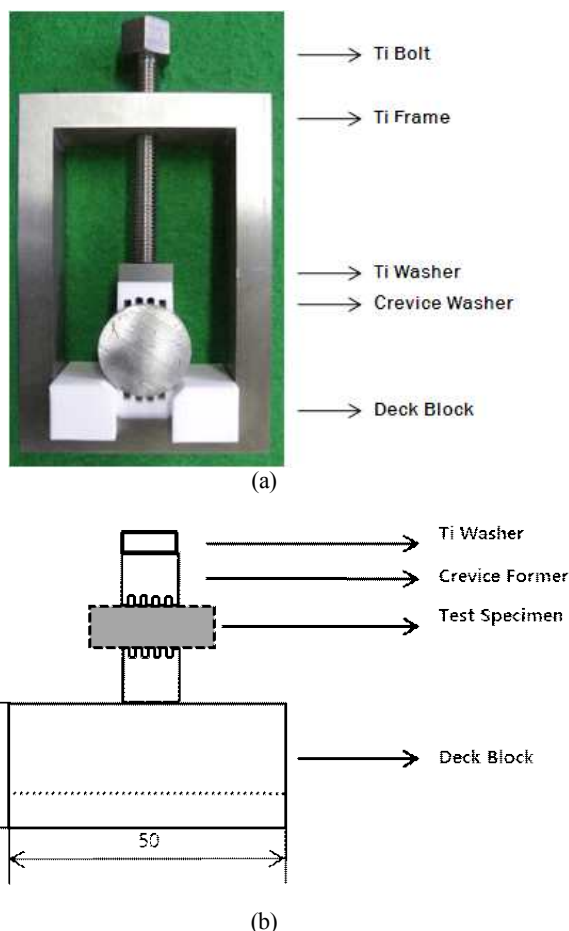
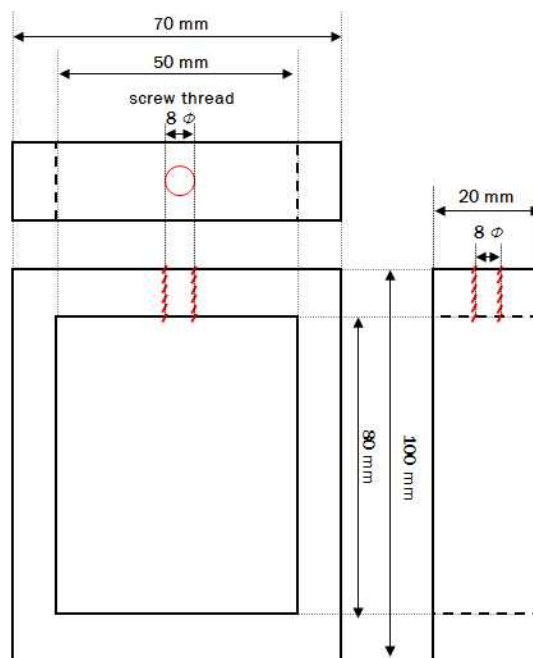

Fig. 4. Assembled crevice test apparatus for (a) cylindrical specimen and (b) plate specimen.

resistance against pitting or crevice corrosion. Crevice was formed with fittings on Fig. 5 and Fig. 6 preventing galvanic corrosion when a specimen makes contact with titanium frame. Left and right PTFE block decks were located in advance on which a cylindrical and plate specimen was spanned and held as shown in Fig. 4. A lower crevice former was made position between them which had a same curvature with a specimen. The curvature had been calibrated to peristaltic radius of curvature with the mounted specimen. The curvature of lower crevice former for a part of circular arc geometry (e.g. of big size specimen) should be convex upwards. Also, CCT of the plate type specimen can be measured with a flat crevice former. The crevice formers and supporting deck blocks are made of TFE-fluorocarbon that contact to a cylindrical specimen and the material for the clamp and bolt is titanium grade 2 for corrosion resistance. A specimen was mounted on the lower crevice former followed by topping an upper crevice former on it. A titanium washer was installed on the upper crevice former for making stress evenly dis-



Crevice Corrosion Test Frame Dimensions (mm)				
Outside		Inside		Thickness
Length	Width	Length	Width	
100	70	80	50	20

Fig. 5. Ti frame of assembled crevice test apparatus for a specimen of benchmark scale.

tributed on the surface of the specimen when a force added with a titanium bolt contacted on top of the washer. Finally the titanium bolt was wrenched up to the determined amount of torque with a torque wrench.

Requirements for materials and dimensions of crevice corrosion temperature test assembly

- Materials of assembly: titanium grade 2 equivalent<sup>13)</sup>
- Dimension of assembly: various dimensions fit for cylindrical products
- Artificial crevice former: machined PTFE<sup>14)</sup> upper and lower blocks rounded surface with grooves for contacting to a specimen
- Supporting decks: right and left PTFE<sup>14)</sup> blocks with rounded surface for a specimen to be pegged inside the assembly
- Titanium bolt (ISO 4017; M8)<sup>15)</sup> for applying torque to the specimens

Fig. 7 shows the form and dimension of PTFE crevice former for cylindrical and plate specimen. In the case of cylindrical specimen, width of crevice former cylindrical

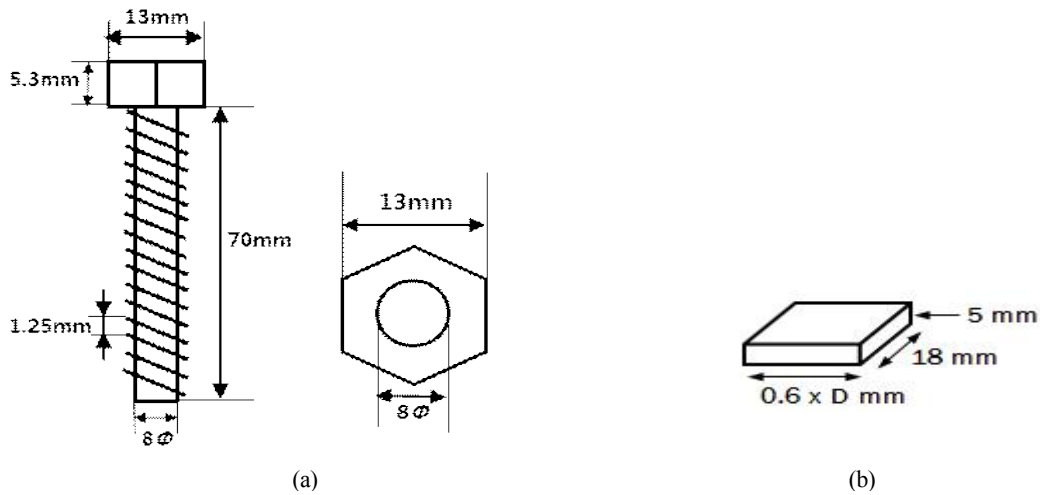

Components	Ti Bolt and Dimensions of Ti Bolt and Ti Washer (mm)				
	Width	Thickness	Length	Pitch	Screw dia.
Ti Bolt	13 (head)	5.3 (head)	70	1.25	8 (out dia.)
Ti Washer	0.6 x D	5	18	-	-

(c)  
**Fig. 6.** Ti Bolt and Ti Washer of assembled crevice test apparatus for a specimen of benchmark scale; (a) Ti bolt with hexagon bolt head-ISO 4017, (b) Ti washer, (c) dimension of bolt and washer.

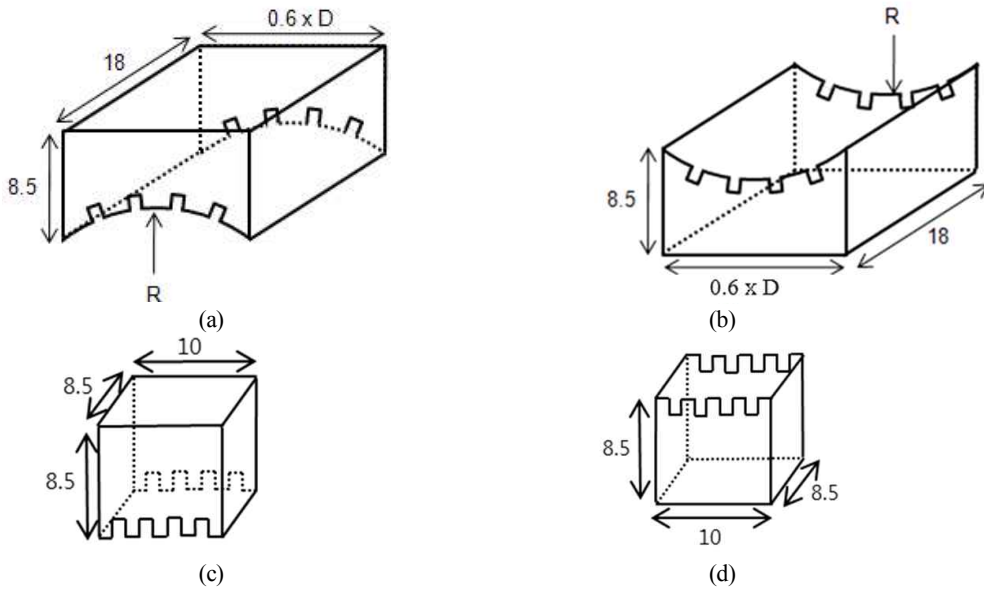

Dimension of crevice former for cylindrical specimen (mm)					
Upper Part		Lower Part		Thickness	Number of Slots, min.
Length	Width	Length	Width		
18	0.6 x D	18	0.6 x D	8.5	4
Dimension of crevice former for plate type specimen (mm)					
Upper part		Lower Part		Thickness	Number of slots, min.
Length	Width	Length	Width		
8.5	10	8.5	10	8.5	4

(e)  
**Fig. 7.** PTFE crevice former; (a) upper part for the cylindrical specimen, (b) lower part for the cylindrical, (c) upper part for the plate specimen, (d) lower part for the plate specimen, (e) dimension of the parts.

specimen shall be modified depending on the diameter (D) of the specimen, and  $0.6 \times D$  is recommended. In the case of plate specimen, is used the flat crevice former. The width and depth of the slots were machined to at least 1 mm respectively and when the torque is applied for plate specimen, it should be prepared not to be twist.

**3.2 First trial applied torque to obtain the same CCT between plate specimen and same diameter-cylindrical specimen of different PREN's stainless steels**

**1) Plate specimen**

CCT was measured for the plate specimen in accordance with the condition of 6 % FeCl<sub>3</sub>, 1.58 Nm<sup>1)</sup>. The typical quantitative results of the tests are summarized in Table 4. The experimental variables are test temperature

by 5 °C steps, weight loss and weight loss per unit area, sign of crevice corrosion, and crevice corrosion depth by the 3D microscope. Finally, the CCT of UNS S32050 plate was decided as 40 °C from the table.

**2) Cylindrical specimen**

Several torque values were applied by trial and error for the cylindrical type specimen in order to find out the same CCT of the plate type specimen with a torque. CCT was measured for the 25 mm diameter specimen in accordance with the condition of 6 % FeCl<sub>3</sub>, and the torque of 1.86 Nm for cylindrical specimen has shown the same CCT of plate type one.

The procedure of experiment and results for only 1.86 Nm of torque is demonstrated for the brevity as follows. 1.86 Nm of torque was applied to the crevice assembly

**Table 4. Summary of CCT test for the plate type specimen of UNS S32050 (6 % FeCl<sub>3</sub>, 1.58 Nm)**

Alloy		UNS S32050 (plate type)		
Test Temperature, °C		35	40	45
Weight loss, mg		1.4	1.7	3.8
Weight loss per unit area, mg/cm <sup>2</sup>		0.07	0.08	0.2
Sign of crevice corrosion (>0.1 mg/ cm <sup>2</sup> )		No	Yes	Yes
Crevice Corrosion Depth (μm)	Max	-	32.6	32.7
	Average	-	20.0	21.4

**Table 5. Summary of CCT test for the cylindrical type specimen of UNS S32050 (6 % FeCl<sub>3</sub>, 1.86 Nm)**

Alloy		UNS S32050 (The diameter; 25 mm)		
Test Temperature, °C		35	35	35
Weight loss, mg		0	0.1	0.7
Weight loss per unit area, mg/cm <sup>2</sup>		0.00	0.00	0.02
Sign of crevice corrosion (>0.1 mg/ cm <sup>2</sup> )		No	No	No
Crevice Corrosion Depth (μm)	Max	-	-	12.6
	Average	-	-	8.6

**Table 6. Summary of CCT test for the cylindrical type specimen of UNS S32050 (6 % FeCl<sub>3</sub>, 1.86 Nm)**

Alloy		UNS S32050 (The diameter; 25 mm)		
Test Temperature, °C		40	40	40
Weight loss, mg		0	0	0.6
Weight loss per unit area, mg/cm <sup>2</sup>		0	0	0.02
Sign of crevice corrosion (>0.1mg/cm <sup>2</sup> )		Yes	Yes	Yes
Crevice Corrosion Depth (μm)	Max	32.5	35.9	40.4
	Average	21.3	22.4	23.6

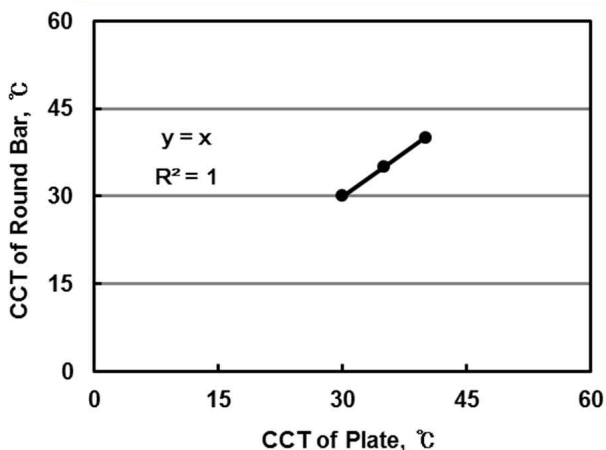

Fig. 8. Relationship between CCT of plate and CCT of cylindrical specimen (diameter; 25 mm).

for the CCT tests of cylindrical type specimen. Diameter of the specimen was 25 mm. The corrosion depth of cylindrical specimen was measured 3 times with the 3D microscope after immersed in the solution of 35 °C, 6 % FeCl<sub>3</sub> solution, 24hr. The quantitative results of the tests are summarized in Table 5. The crevice assembly for the cylindrical specimen with 1.86 Nm in 35 °C did not generate crevice corrosion which exceeded the standard criterion, and then the temperature of test was risen to 40 °C. The procedure was repeated in 40 °C, and the results of it was tabulated in Table 6. As shown in this table, the CCT of cylindrical UNS 32050 specimen has been evaluated as 40 °C in all of 3 trials. Therefore, the torque needed for the cylindrical specimen is deduced to 1.86 Nm which shows the same CCT for the plate type specimen with the torque of 1.58 Nm.

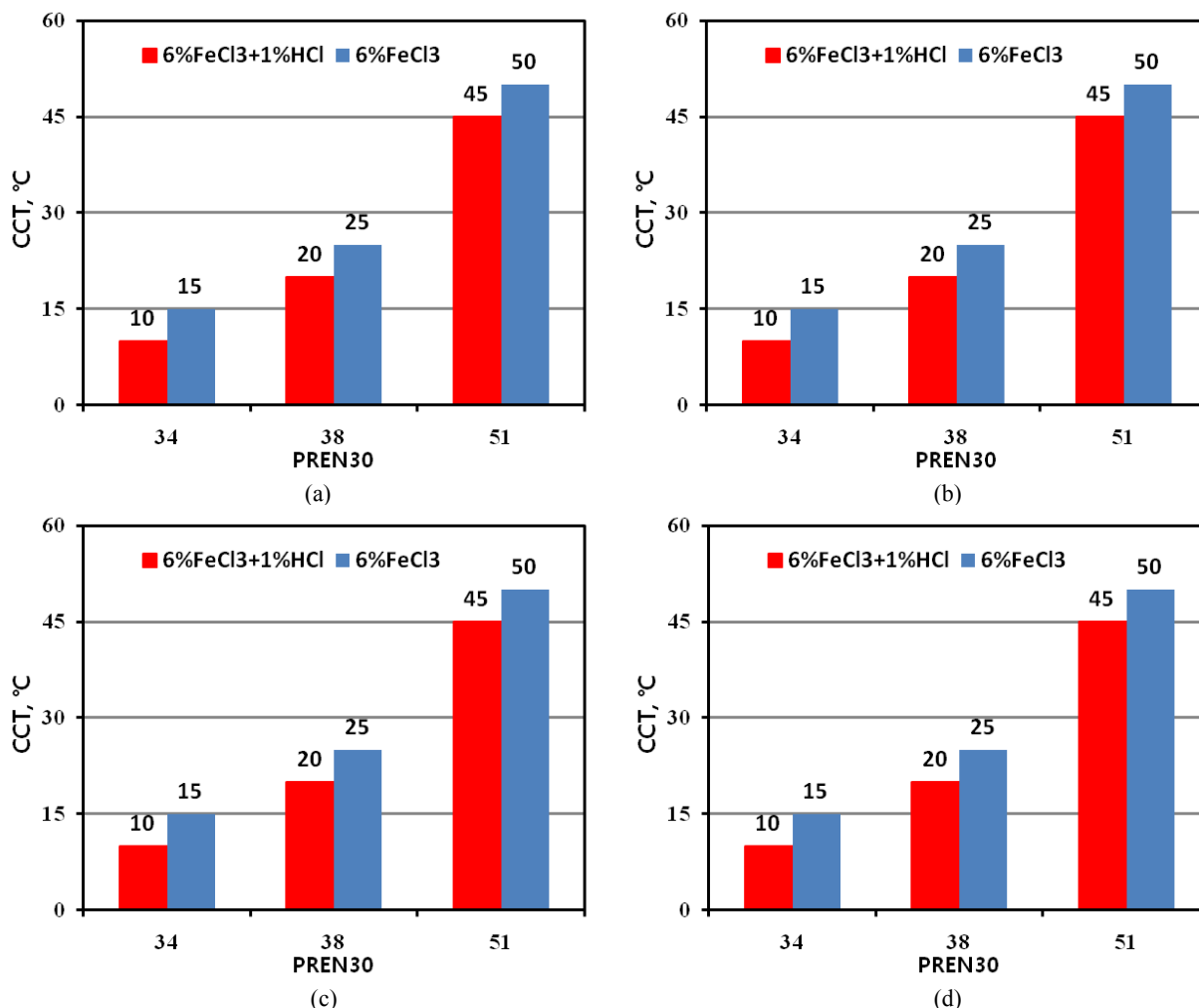

Fig. 9. CCT of the austenitic stainless steels determined in 6% FeCl<sub>3</sub> + 1% HCl and 6% FeCl<sub>3</sub> solution; (a) plate, and (b) round bar (D; 35 mm), (c) round bar (D; 25 mm), (d) round bar (D; 15 mm).



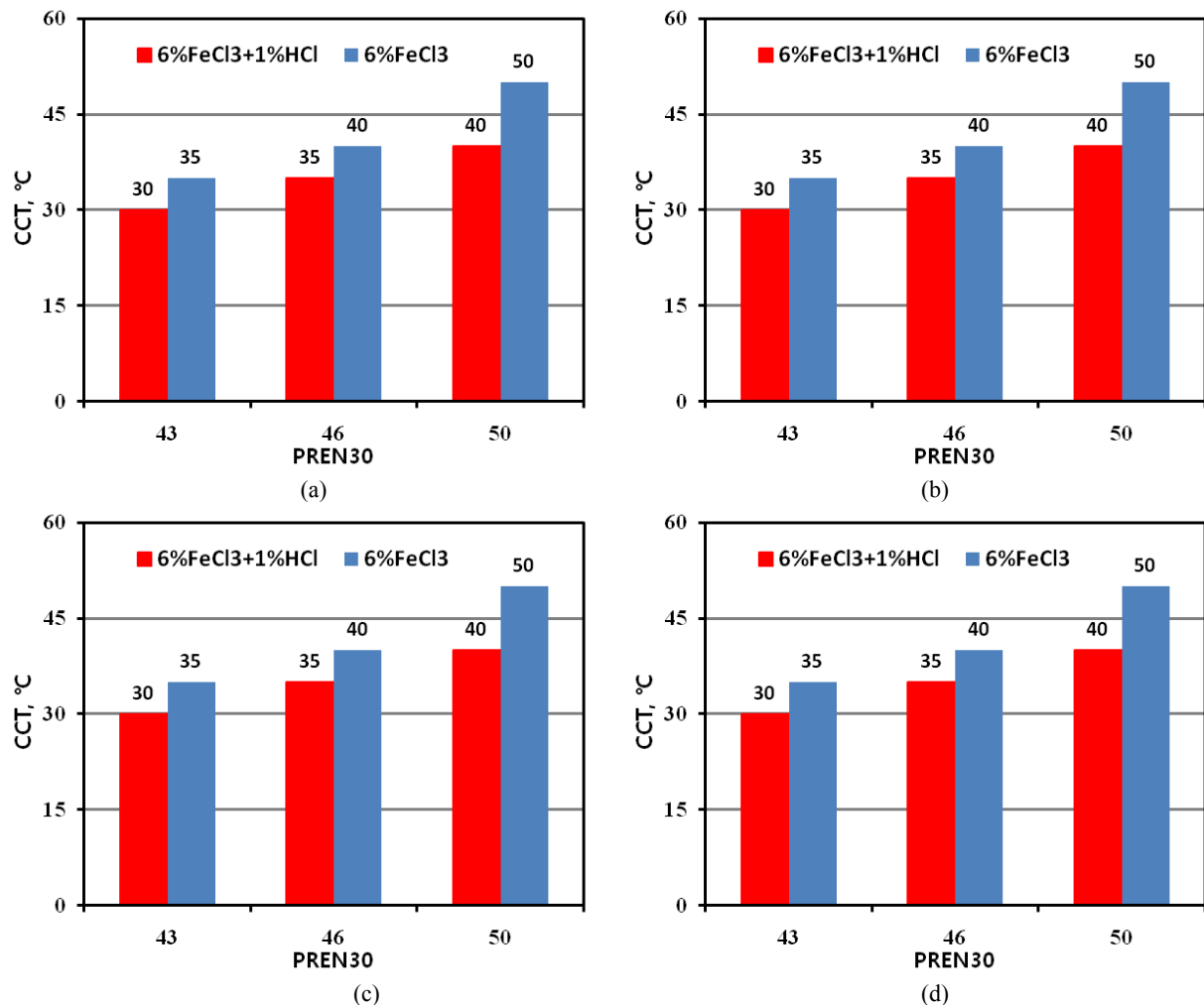

Fig. 10. CCT of the duplex stainless steel determined in 6 % FeCl<sub>3</sub> + 1 % HCl and 6 % FeCl<sub>3</sub> solution; (a) plate, and (b) round bar (D; 35 mm), (c) round bar (D; 25 mm), (d) round bar (D; 15 mm).

### 3.3 Possibility and limitation of first trial applied torque - 1.86 Nm for 25 mm diameter specimen using various PREN's alloys

6 % FeCl<sub>3</sub> solution was used as a test solution with equilibrium temperature maintained. Liter dimension of glass reactor was used being installed with a water condenser for keeping solution from evaporation and concentration change. Each specimen surface was ground with #120 SiC paper of which corners were filleted and ground for staving off edge effect. The specimen is installed in the test kit to which designated torque is applied with the torque wrench for torque fix control. This kit what it called the crevice former assembly is then immersed in the test solution for 24 hours. When the weight loss of specimen exceeds 0.1 mg/cm<sup>2</sup>, it may be regarded as the symptom of crevice corrosion initiation, but the exact

criterion for crevice corrosion initiation is that the depth of corrosion exceeds 0.025 mm. This criterion was applied to this study with the 3D optical microscope. Fig. 8 reveals the relationship between CCT of a plate and CCT of a cylindrical specimen (diameter; 25 mm). The relationship between CCT of the plate and CCT of the cylindrical specimen was perfectly linear and its determination coefficient was 1 for the group 1 alloys (austenitic and duplex stainless steels). It was 1.86 Nm that applied torque for all of 3 kinds of stainless steels and another 3 kinds of duplex stainless steels. Test solution was 6 % FeCl<sub>3</sub> + 1 % HCl. However, some alloys showed the same CCT in both the plate and the cylindrical specimen. Thus, A series of experiments followed have been intensively focused upon to find out a reliable test condition for concord of CCT with different geometries.

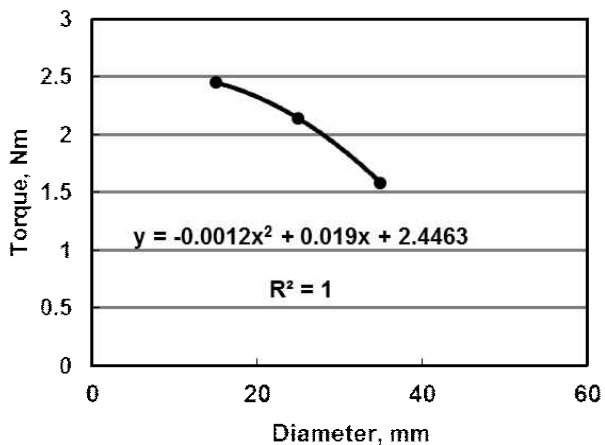

Fig. 11. Relationship between tube diameter and applied torque for CCT test.

### 3.4 General relationship of CCT test conditions between plate and cylindrical shapes

Materials for the test were austenitic stainless steels of PRE 34(A1), 38(A2), 51(A3) and Duplex stainless steels of PRE 43(D1), 46(D2), 53(D3). Chemical compositions of them are shown in Table 2 and Table 3. The dimension of plate specimens was 20 mm x 20 mm with thickness of 10 mm, and those of cylindrical specimens were diameters of 35 mm, 25 mm, 15mm with length of 20 mm. The applied torque was changed depending upon the diameter, regardless of PRE number of the specimen. Test solution was 6 % FeCl<sub>3</sub> + 1 % HCl

Fig. 9 shows CCT of the austenitic stainless steels; (a)

plate specimen, (b) cylindrical specimen (D; 35 mm), (c) cylindrical specimen (D; 25 mm), (d) cylindrical specimen (D; 15 mm). The CCT was picked up as PRE of austenitic stainless steel increased, but there were no differences of CCT between plate specimen and cylindrical specimens regardless of their diameters. It was confirmed that this test method and apparatus served to the same CCT all for the plate type specimen and upwards of 35 mm dia. cylindrical specimens with 1.58 Nm, 25 mm dia. cylindrical specimen with 2.14 Nm, and 15 mm dia. cylindrical specimen with 2.45 Nm, irrespective of PRE of alloys and diameter of specimens. Fig. 10 shows CCTs of the duplex stainless steels; (a) plate, (b) cylindrical (D; 35 mm), (c) cylindrical (D; 25 mm), and (d) cylindrical (D; 15 mm). CCT of duplex stainless steels increases as PRE of them ramps up, but there were no differences of CCT between plate specimen and cylindrical specimens regardless of their diameters. It was substantiated that this test method and apparatus served to the same CCT all for the plate type specimen and upwards of 35 mm dia. cylindrical specimens with 1.58 Nm, 25 mm dia. cylindrical specimen with 2.14 Nm, and 15 mm dia. cylindrical specimen with 2.45 Nm, irrespective of PRE of alloys and diameter of specimens.

Fig. 11, in turn, was set out from the whole data above. Fig. 11 shows the relation of torque for the same CCT both of plate and cylindrical specimens even though the diameters of them are varied. The applied torque for various diameter of the specimen can be calculated by the equation (1). The torque from this equation let various

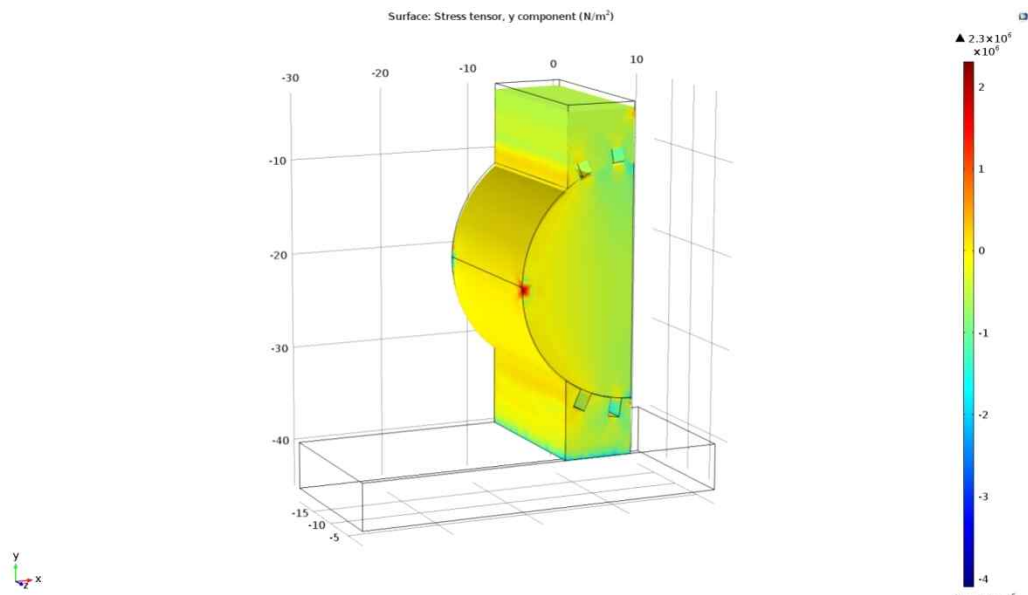

Fig. 12. Result of stress tensor (y component) distribution with strain (x-y-z). [symmetry model: torque 2.14 Nm(= vertical force 1103,9 N)].

diameter of cylindrical specimen lead to the same CCT with that of plate specimen.

Applied torque, Nm =  $-0.0012D^2 + 0.019D + 2.4463$  (1)  
(D; the diameter of cylindrical specimen, mm)

The torque of 1.58 Nm for the specimen can be applied, provided they are plate type or upwards of 35 mm diameter cylindrical specimens. However, this method cannot be used for the specimen of less than 15 mm diameter which needs so high torque that may lead to deformation of PTFE crevice formers.

The FEM modeling was performed to evaluate stress concentration and deformation problems of crevice formers in CCT test assembly. The geometry used in this modeling is shown in Fig. 12. Result of stress tensor (y component) distribution with strain (x-y-z) is laid out in this figure. Symmetry model was used to reduce calculation time. The torque used in this calculation run was 2.14 Nm. The result does not show a serious local stress concentration or deformation of teeth in crevice formers. Modelling works are being continued to evaluate whether uniform contribution of stress is applied on whole part of specimen contacted to crevice formers.

#### 4. Conclusions

Conclusions were attained from a series of experiments for CCT measurements of the plate type and cylindrical stainless steel specimens with various diameter that have different microstructures (austenitic and duplex) and PREs.

- 1) The apparatus to evaluate CCT of the plate type and cylindrical specimens was developed and the same CCT was acquired regardless of the shape (plate type or cylindrical type) and diameter of the specimens provided that the specimens came from the same alloy.
- 2) The applied torque can be calculated for the different diameter of the cylindrical specimens with the relation below. However, upwards of 35 mm diameter cylindrical specimen should be applied with the 1.58 Nm which is the same torque for the plate type specimen, and this test method cannot be used for the cylindrical specimen of less than 15 mm diameter.

Applied torque, Nm =  $-0.0012D^2 + 0.019D + 2.4463$   
(D; the diameter of cylindrical specimen, mm)

#### Acknowledgement

This work was supported by a grant from 2015 Research funds of Andong National University.

#### References

1. ASTM G 48, Standard Test Methods for Pitting and Crevice Corrosion Resistance of Stainless Steels and Related Alloy by Use of Ferric Chloride Solution (2015).
2. ASTM G 46, Standard Guide for Examination and Evaluation of Pitting Corrosion (2013).
3. ASTM F 746, Standard Test Method for Pitting or Crevice Corrosion of Metallic Surgical Implant Materials (2014).
4. ASTM G 78, Standard Guide for Crevice Corrosion Testing of Iron-Base and Nickel-Base Stainless Alloys in Seawater and Other Chloride-Containing Aqueous Environments (2015).
5. ASTM G 150, Standard Test Method for Electrochemical Critical Pitting Temperature Testing of Stainless Steels (2013).
6. KS D0219, Method of ferric chloride Test for Stainless Steels (2015).
7. KS D0269, Potentiostatic Polarization Test Method for Determination of Critical Pitting Temperature for Stainless Steels (2015).
8. KS D0278, Standard Test Methods for Pitting and Crevice Corrosion Resistance of Stainless Steels and Related Alloys by Use of Ferric Chloride Solution (2015).
9. KS D0289, Test Method for Determination of Resistance to Pitting and Crevice Corrosion of Metallic Materials for Surgical Implants (2014).
10. KS D0297, Test Method for Determination of Pitting Corrosion Resistance for Seal Weldment between tube and tube sheet (2014).
11. ISO FDIS 18070, Corrosion of Metals and Alloys – Crevice Corrosion Formers with Disc Springs for Flat Specimens or Tubes of Stainless Steels in Corrosive Solutions (2015).
12. ISO FDIS 18089, Corrosion of Metals and Alloys – Determination of the Critical Crevice Temperature (CCT) for Stainless steels under Potentiostatic Control (2015).
13. R. Boyer, G. Welsch, and E. W. Collings, ed., *Materials Properties Handbook: Titanium Alloys*, p. 167, ASM International, Materials Park, OH, USA (1994).
14. ASTM D 3294-15, Standard Specification for Polytetrafluoroethylene (PTFE) Resin Molded Sheet and Molded Basic Shapes (2015).
15. ISO 4017, Hexagon Head Screws – Product grades A and B (2014).