

Microwave-assisted pretreatment technologies for the conversion of lignocellulosic biomass to sugars and ethanol: a review

Pradeep Puligundla^{1,*}, Sang-Eun Oh² and Chulkyoon Mok¹

¹Department of Food Science & Biotechnology, Gachon University, Seongnam 13120, Korea

²Department of Biological Environment, Kangwon National University, Chuncheon 24341, Korea

Article Info

Received 27 April 2015

Accepted 24 November 2015

*Corresponding Author

E-mail: puli@gachon.ac.kr

Tel: +82-31-750-5403

Open Access

DOI: <http://dx.doi.org/10.5714/CL.2016.17.1.001>

This is an Open Access article distributed under the terms of the Creative Commons Attribution Non-Commercial License (<http://creativecommons.org/licenses/by-nc/3.0/>) which permits unrestricted non-commercial use, distribution, and reproduction in any medium, provided the original work is properly cited.

Abstract

Lignocellulosic biomass conversion to biofuels such as ethanol and other value-added bio-products including activated carbons has attracted much attention. The development of an efficient, cost-effective, and eco-friendly pretreatment process is a major challenge in lignocellulosic biomass to biofuel conversion. Although several modern pretreatment technologies have been introduced, few promising technologies have been reported. Microwave irradiation or microwave-assisted methods (physical and chemical) for pretreatment (disintegration) of biomass have been gaining popularity over the last few years owing to their high heating efficiency, lower energy requirements, and easy operation. Acid and alkali pretreatments assisted by microwave heating meanwhile have been widely used for different types of lignocellulosic biomass conversion. Additional advantages of microwave-based pretreatments include faster treatment time, selective processing, instantaneous control, and acceleration of the reaction rate. The present review provides insights into the current research and advantages of using microwave-assisted pretreatment technologies for the conversion of lignocellulosic biomass to fermentable sugars in the process of cellulosic ethanol production.

Key words: lignocellulosic biomass, microwave pretreatment, activated carbon, bioenergy, ethanol

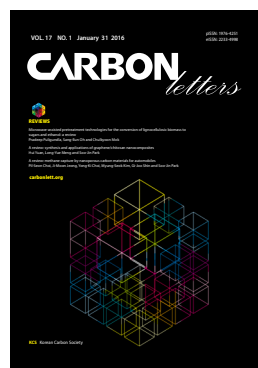

<http://carbonlett.org>

pISSN: 1976-4251

eISSN: 2233-4998

Copyright © Korean Carbon Society

1. Introduction

Lignocellulosic biomass typically comprises agricultural residues such as corn stover, wheat straw, and rice straw; agricultural by-products such as hulls, bran, and bagasse; and energy crops such as switchgrass, *Miscanthus*, mixed grasses, and hybrid poplar [1]. In recent years, a tremendous amount of research on the development of technologies for efficient lignocellulosic biomass conversion to biofuels (e.g. ethanol, butanol) and other value-added bio-products (e.g. activated carbons) has been performed. Lignocellulosic material predominantly consists of three bio-polymers, cellulose, hemicelluloses, and lignin. Typically, most of the lignocellulosic biomass from agriculture consists of about 40%-50% cellulose, 20%-30% hemicellulose, and 10%-25% lignin, as shown in Table 1 [2,3]. Cellulose is an unbranched linear polymer of β -(1 \rightarrow 4)-D-glucofuranose units. Hemicellulose is a branched linear polymer derived from anhydrides of various sugars. However, it possesses a low degree of polymerization and therefore exhibits low mechanical and chemical resistance. Hemicellulose is always accompanied by cellulose and lignin, and does not exist in free form (Fig. 1). Lignin is a non-carbohydrate polymer and it acts as a barrier for solutions or enzymes by linking to both hemicelluloses and cellulose. The lignin molecule is a very complex, cross-linked, 3-dimensional polymer formed from phenolic units, and it provides strength and structure to the plant cell walls.

Table 1. Composition of lignocellulosic materials and wastes [2,3]

Lignocellulosic material	Cellulose (%)	Hemicellulose (%)	Lignin (%)
Hardwood stems	40-55	24-40	18-25
Softwood stems	45-50	25-35	25-35
Nut shells	25-30	25-30	30-40
Grasses	25-40	35-50	10-30
Paper	85-99	0	0-15
Newspaper	40-55	25-40	18-30
Leaves	15-20	80-85	0
Wheat straw	30	50	15
Corn cobs	45	35	15
Switchgrass	45	31.4	12
Rice straw	35-45	18-25	10-25
Tobacco chops	22-30	15-20	15-25
<i>Miscanthus</i>	35-40	16-20	20-25
<i>Arundo donax</i>	30-38	18-22	8-20

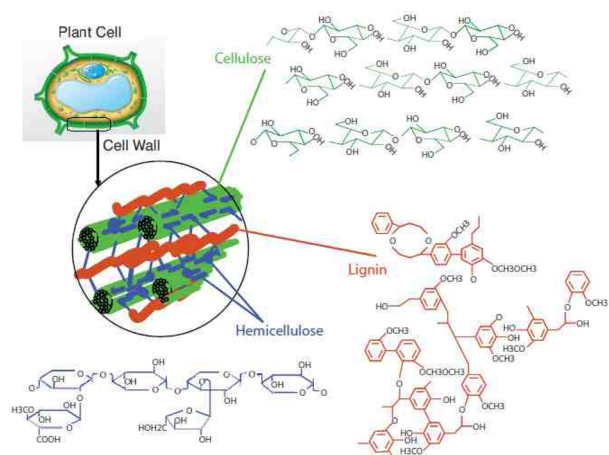
**Fig. 1.** Lignocellulose structure containing cellulose, hemicellulose, and lignin.

2. Biomass-Derived Activated Carbon & Graphene

Activated carbon is a carbonaceous material that is prepared by the carbonization/pyrolysis of high carbon content materials, such as wood, petroleum, coal, etc. In order to reduce environmental pollution and the production cost, the preparation of activated carbon using renewable and less expensive precursors has attracted the interest of researchers worldwide. The precursors of interest are primarily agricultural and industrial lignocellulosic byproducts and forest wastes, such as rice straw, coconut shell, rubber-seed shell,

hazelnut shell, cotton stalks, sugar beet bagasse, sawdust, bamboo, oil palm fiber, waste apricot, and coconut husk. The conversion of locally, abundantly available solid biomass waste into activated carbon would lend greater economic value by providing an alternative to costly activated carbon. Because of the rich carbon content of lignin, lignocellulosic biomass is a better choice to be used as precursor for producing activated carbon [4]. Activated carbon derived from lignocellulosic biomass is widely used for waste water treatment, air pollution treatment, chemical processes, and adsorption of volatile organic compounds [5]. Activated carbon is a well-known adsorbent due to its unique and versatile properties, namely high surface area, microporous structure, and favorable pore size, which allow access of gases/liquids into the internal pore surface and a high degree of surface reactivity [6].

The preparation of activated carbon from lignocellulosic biomass generally involves two main steps. The first step is char production from biomass with a carbonization/pyrolysis process, wherein moisture and volatile compounds are removed from the biomass [7]. Carbonization is usually done by pyrolysis in an inert atmosphere at temperatures lower than 500°C [8]. From char, activated carbon can be produced using three different types of activation processes: physical (e.g. CO₂, steam), chemical (e.g. KOH, ZnCl₂, strong base, Cu(NO₃)₂, H₃PO₄) and physicochemical (e.g. NaOH/CO₂, Ce/CO₂, CaO/steam, metal nitrate/steam). The activation process leads to the production of activated carbon with high porosity, large surface area, and high pore volume [6].

Graphene is the name given to a two-dimensional sheet of sp²-hybridized carbon. Porous graphene-like nanosheets with a large surface area were synthesized via a simultaneous activation-graphitization route from renewable biomass waste coconut shell [9]. Parshetti et al. [10] demonstrated a novel method to produce porous graphene-like nanosheets from lignocellulosic fiber of oil palm empty fruit bunches (EFB) by a thermal graphitization technique for CO₂ capture. Recently, a simple, eco-friendly, and scalable method of obtaining graphene from dead camphor leaves (*Cinnamomum camphora*) using one-step pyrolysis was reported [11]. In this method, under a flowing nitrogen atmosphere, dead camphor leaves were heated to 1200°C at 10°C/min and then cooled to room temperature without external disturbances. With the help of π - π interaction with D-Tyrosine and centrifugation, few layer graphene was separated from the final pyrolytic components.

3. Biomass-to-Fuel Conversion via Hydrolysis/Fermentation Pathway

Lignocellulosic materials have strong potential to be used as raw materials for the fermentative production of biofuels. Bioethanol from lignocellulosic biomass (also called second-generation ethanol) shows some distinct advantages compared to first-generation ethanol as lignocellulosic biomass does not compete directly with crops grown for food, and therefore land use efficiency can be increased. In addition, the manufacture of chemicals and production of energy from biomass on a large-

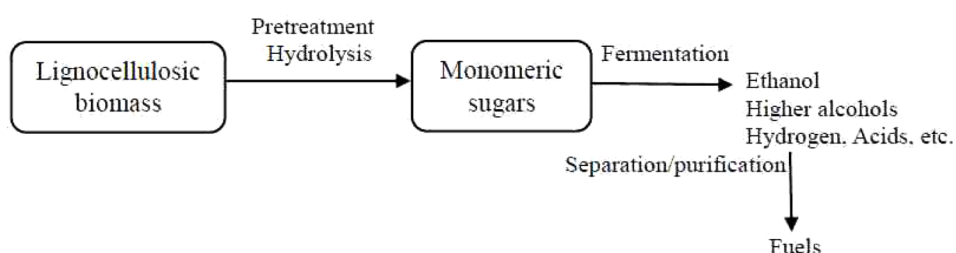

Fig. 2. Steps in conversion of lignocellulosic biomass to fuels.

scale basis could be possible due to its abundant availability [12]. Biomass-to-fuel conversion is accomplished through different steps, namely pretreatment, hydrolysis, fermentation, and separation/distillation, as shown in Fig. 2.

3.1. Pretreatment of biomass

Pretreatment of lignocellulose is a key step for efficient conversion of biomass to fuels. It affects the efficiency and methodology of the subsequent saccharification process [12]. The primary goal of pretreatment is to overcome the recalcitrant nature of cellulosic biomass [13]; an example of disruption of the higher order structure of lignocellulose upon pretreatment is depicted in Fig. 3 [2,14]. The pretreatment step is also aimed at increasing the surface area and pore volume, as well as reducing cellulose crystallinity. The recalcitrant nature of lignocellulosic biomass severely impedes the yield of fermentable sugars during hydrolysis. Biomass recalcitrance is due to two main physical factors, the crystalline structure of cellulose and matrix polysaccharides and the lignin coat of the cellulose fibril, which acts as a physical barrier to enzymatic attack on cellulose [15]. Chemical effects of pretreatment include increased solubility and depolymerization of lignocellulose polymer structures, and breakage of crosslinking between macromolecules [16].

The pretreatments can be classified into physical [17] or physicochemical [18], chemical [19], and biological [20] methods or combinations thereof [21-23]. The effectiveness of each type of pretreatment is presented in Table 2 [24-27]. Each type has unique advantages and disadvantages. However, most of the available pretreatment methods fail to achieve the desired result

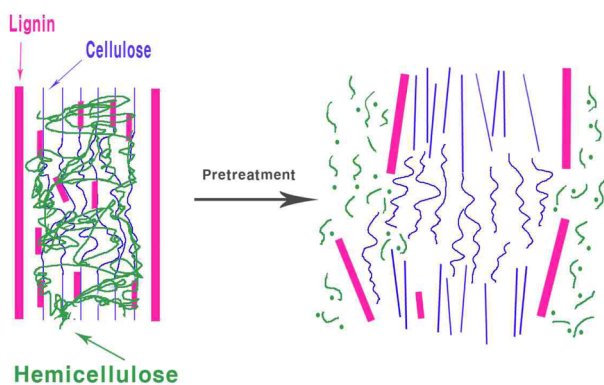

Fig. 3. Disruption of recalcitrant structures of lignocellulose upon pretreatment. Modified from Kumar et al. [2] and Hsu et al. [14].

(i.e. effective disruption of biomass structure) and suffer from relatively low sugar yields and severe reaction conditions (high temperature and/or high pressure).

A pretreatment process featuring mild reaction conditions is highly desired because it would reduce sugar degradation and inhibitor formation and also lower initial capital costs [28]. The pretreatment step in biomass conversion is relatively expensive [29], and accounts for as much as 18% of the total ethanol production cost [1,30,31]. Enhancing yields through improved pretreatment would reduce all other unit costs. Therefore, the cost of production can be significantly reduced by increasing the pretreatment efficiency. At present, pretreatment processes are designed to facilitate the subsequent hydrolysis, thereby yielding maximum sugars with minimum fermentation inhibitory compounds. Pretreatment technologies are being investigated on both laboratory scale and in pilot plants all over the world.

3.1.1 Characteristics of an ideal pretreatment process

An ideal pretreatment should be affordable, with low energy and resource consumption, and should not produce any waste streams. It is necessary to promote high digestibility of cellulose, and must have high versatility for feedstock. In addition, there should be low sugar decomposition, low water or high solids, and low chemical consumption during the process. Furthermore, it should have low operational risk and must be safe to operate and the cost of construction materials should be low. It should further promote cost effective downstream processing.

4. Fundamentals of Microwave Heating Technology

Microwave heating involves a complex mechanism that depends on numerous factors i.e., propagation of microwaves governed by Maxwell's equations for electromagnetic waves, the interactions between microwaves and dielectric properties of material, and the heat dissipation governed by heat and mass transfer. The electric field of commonly used irradiation frequency (2450 MHz) oscillates 4.9×10^9 times per second, and the sympathetic agitation of the molecules generates heat [32]. Therefore, dielectric properties govern the ability of materials to heat in microwave, including the dielectric constant (ϵ') and dielectric loss (ϵ''). The ability of a material to convert electromagnetic energy into heat energy at a given frequency and temperature is calculated using:

Table 2. Various physical, chemical, and biological methods for the pretreatment of lignocellulosic biomass [24-27]

Pretreatment process	Types	Effective for
Physical pretreatment	Mechanical comminution: milling (hammer, disc or attrition, compression), grinding, chipping, extrusion, pressing	Particle-size reduction Reducing cellulose crystallinity and degree of polymerization
	Autohydrolysis: uncatalysed steam-explosion, liquid hot water, hydrothermolysis, steam and mechanical shear, pyrolysis, dry heat expansion, moist heat expansion	Hemicellulose degradation Lignin transformation
	High energy radiation: gamma, electron beam, microwave, photooxidation	Increasing the accessible surface area of cellulose to enzymes
Chemical pretreatment	Alkali- sodium hydroxide, ammonium hydroxide Acids-dilute or concentrated sulphuric acid, dilute or concentrated hydrochloric, nitric, phosphoric acids	Hemicellulose hydrolysis to xylose and other sugars; alters lignin structure
	Oxidizing agents: peracetic acid, sodium hypochlorite, sodium chlorite, hydrogen peroxide Solvents: methanol, ethanol, butanol, phenol, ethylamine, hexamethylenediamine, ethylene glycol	Increasing the accessible surface area Removal of hemicelluloses and lignin
	Gases-ammonia, chlorine, nitrous oxide, ozone, sulfur dioxide.	Reducing lignin content
Biological pretreatment	Cellulolytic microorganisms-bacteria, fungi, and actinomycetes	Degradation of lignin and hemicelluloses
	Cellulolytic enzymes- endoglucanases, exoglucanases, β -glucosidases	Increasing the accessible surface area; hydrolysis of cellulose into fermentable sugars
	Hemicellulose degrading enzymes: endoxylanases, exoxylanase, xylosidase, α -L-arabinofuranosidase, 1,4- β -D-mannanase, 1,4- β -mannosidases, α -galactosidase	Hemicellulose hydrolysis to xylose and other sugars
	Lignin degrading enzymes: lignin peroxidase, manganese peroxidase, laccases	The delignification of wood and agricultural residues

$$\epsilon'' / \epsilon' = \tan \delta \quad (1)$$

where δ is the dissipation factor of the sample, ϵ'' is the dielectric loss, which measures the efficiency with which heat is generated from the electromagnetic radiation, and ϵ' is the dielectric constant, which gives the ability of a molecule to be polarized by an electric field [33]. A high value of the dissipation factor δ indicates large susceptibility to microwave energy. Microwave heating has the capacity to induce explosions among the particles and therefore improves the disruption of recalcitrant structures. Change in the ultra-structure of cellulose has been reported after irradiation [34].

Microwave irradiation is highly effective and energy saving [35]. There are several advantages of microwave heating over conventional heating systems. These include reduced process energy requirements, selective processing, and precise control [36]. In addition, the heating is volumetric and rapid because the heat is generated internally through direct interaction between the electromagnetic field and components of the heated material [37]; i.e., microwaves couple directly with the molecules of the entire reaction mixture. In contrast, conventional heating is a slow and inefficient method of transferring energy into the reacting system. Some strengths and weaknesses of microwave

Table 3. Strengths and weaknesses of microwave heating for pretreatment process

Strength	Weakness
Rapid internal heating	Uneven distribution of microwave energy
Instant control	Overheating
Acceleration of reaction rate	Non-uniform heating or thermal runaway
Selective interaction with active groups	Need for electrical energy, high energy costs

heating are given in Table 3.

Microwave irradiation of biomass is a promising pretreatment process because it utilizes thermal and specific (non-thermal) effects generated by microwaves in aqueous environments [38]. Low temperature pretreatment is generally preferred to avoid hemicellulose degradation and to improve the pentose yield [39]. Due to its non-thermal and thermal effects, microwave radiation has successfully been applied for biomass pretreatment. These effects can cause fragmentation and swelling, leading to

degradation of lignin and hemicellulose in biomass [40]. Microwave energy for biomass pretreatment was first introduced by Ooshima et al. [41], who used it to pretreat different hardwoods and softwoods.

5. Pretreatment Using Microwave Radiation

5.1. Microwave-assisted physical pretreatment

A novel, environment-friendly, and effective pretreatment for biomass was reported using combined ball milling and microwave irradiation [42]. It has been shown that combined ball milling for 1 h with microwave irradiation for 20 min can replace BM3 (ball milling for 3 h) and BM6 (ball milling for 6 h) with the same or higher glucose yield while saving 54.8% and 77.4% energy consumption, respectively. Furthermore, no chemicals are required for this process.

5.2. Microwave-assisted chemical pretreatment

A significant improvement in the total reducing sugar yield from rice straw and bagasse has been reported using microwave pretreatment [41]. In this process, rice straw and bagasse with water content of 84% or 94% were irradiated with 2450 MHz microwaves (170°C-200°C for 5 min) in sealed glass vessels. This pretreatment resulted in enhanced substrate accessibility, 1.6 times greater in the rice straw and 3.2 times greater in the bagasse, for enzymatic hydrolysis compared to the untreated samples. Likewise, pretreated bagasse and rice hulls using microwave radiation yielded 77%-84% of total available reducing sugars [43]. Microwave pretreatment substantially improved the recovery of fermentable sugars from sugarcane bagasse [44]. Microwave-assisted dilute nitric acid pretreatment has been shown to enhance the enzymatic digestibility of rice straw by 14% when compared to the convection heating mode, and a reduction of the pretreatment time from 60 min to 7 min was also observed [45]. Microwave-assisted pretreatment (30 min at 700 W) of rice straw soaked in dilute alkali has resulted in an increase in glucose yield of 65% and total carbohydrate conversion of 79% compared with alkali-alone pretreatment [46].

Microwave-assisted alkali pretreatment has also been reported to be a potential alternative to wheat straw pretreatment for enzymatic hydrolysis [22]. In the aforementioned study, the wheat straw exhibited a weight loss of 48.4% and a composition of cellulose 79.6%, lignin 5.7%, and hemicellulose 7.8% after 25 min microwave-assisted alkali pretreatment at 700 W, compared with a weight loss of 44.7% and a composition of cellulose 73.5%, lignin 7.2%, and hemicellulose 11.2% after 60 min conventional alkali pretreatment. Greater amounts of lignin and hemicellulose were removed from wheat straw with microwave-assisted alkali pretreatment in shorter pretreatment time compared with the conventional alkali pretreatment. Production of ethanol at higher concentration and yield from microwave-assisted alkali pretreated wheat straw compared to conventional alkali pretreated wheat straw has been reported [47]. In this study, under simultaneous saccharification and fermentation (SSF), optimal conditions for the microwave-assisted alkali pre-

treated wheat straw were 100 g L⁻¹ substrate, 40°C, 15 mg (cellulose) g⁻¹ (substrate), initial pH 5.3, and 72 h. Under these conditions, the ethanol concentration reached 34.3 g L⁻¹ and the ethanol yield was 69.3%. The SSF optima for the conventional alkali pretreated wheat straw were 100 g L⁻¹ substrate, 40°C, 20 mg (cellulase) g⁻¹ (substrate), initial pH 5.3, and 96 h. Under the optimum conditions, the ethanol concentration and the ethanol yield were 31.1 g L⁻¹ and 64.8%, respectively. In another study, the microwave pretreatment conditions were optimized for ethanol production from wheat straw [48]; under optimal pretreatment conditions, a ratio of biomass to liquid of 80 g kg⁻¹, a NaOH concentration of 10 kg m⁻³, and microwave power of 1000 W for 15 min, the ethanol yields were 148.93 g kg⁻¹ for treated and 26.78 g kg⁻¹ for untreated straw.

Operating parameters that affect sugar recovery in microwave-assisted pretreatment of biomass recently have been discussed by Ethaib et al. [49]. They reported that biomass loading, microwave power level, and irradiation time are the important factors affecting microwave pretreatment efficiency, which reflects sugar recovery. A typical experimental setup for dilute acid pretreatment of biomass under a microwave irradiation environment is given in Fig. 4.

In a study on switchgrass, pretreatment using microwave-based alkali method yielded high sugar levels compared to conventional heating [50]. In a similar study, microwave-based alkali pretreatment of switchgrass and coastal bermudagrass resulted in better sugar yields during subsequent enzymatic hydrolysis; as high as 82% glucose and 63% xylose yields for switchgrass and 87% glucose and 59% xylose yields for Bermuda grass were reported [38].

Microwave-assisted alkali pretreatment (10% NaOH, 4:1 liquid-solid ratio, at temperature 90°C and pretreatment time of 8 min) was shown to enhance the enzymatic digestibility of banana pseudostem; the total yield of reducing sugars reached 84%, compared to convectional heating mode of pretreatment (10% NaOH, 3:1 liquid-solid ratio, at temperature 90°C and pretreatment time of 1.5 h), which yielded only 65% sugars [51]. Recently, microwave-assisted alkali pretreatment using 3% (w/v) NaOH at 180 W for 12 min was found to be effective in reducing lignin content (74%) and holocellulose (24.5%) from

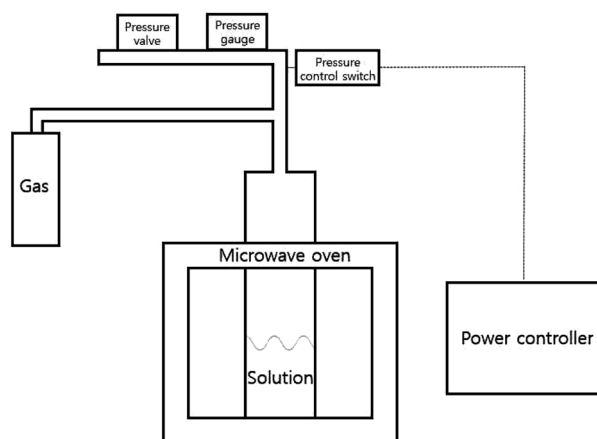

Fig. 4. Block diagram of a typical microwave-assisted dilute acid pretreatment of biomass (based on experimental setup by Chen et al. [40]).

Table 4. Two-stage microwave pretreatment of Kans grass and Giant reed

Lignocellulosic substrate	Pretreatment condition	Resultant effect	Reference
Kans grass (<i>Saccharum spontaneum</i>)	Stage 1: microwave-assisted NaOH pretreatment at 80°C/5 min, 5% (w/v)	6.8 g/100 g of biomass	[63]
	Stage 2: microwave-assisted H ₂ SO ₄ pretreatment at 200°C/10 min, 0.5% (w/v) H ₂ SO ₄	33.8 g/100 g of biomass	
Giant reed (<i>Arundo donax</i>)	Stage 1: microwave-assisted NaOH pretreatment at 120°C/5 min, 5% (w/v) NaOH	6.8 g/100 g of biomass	[63]
	Stage 2: microwave-assisted H ₂ SO ₄ pretreatment at 180°C/30 min, 0.5% (w/v) H ₂ SO ₄	31.9 g/100 g of biomass	

Table 5. Two-stage microwave pretreatment of *Miscanthus*

Biomass	Pretreatment condition	Sugars yield	Reference
<i>Miscanthus sinensis</i>	Single-stage: 1.0% (w/v) NH ₄ OH, 15:1 LSR at 120°C temperature for 15 min	2.9 g of monomeric sugars per 100 g of dried biomass	[64]
	Single-stage: 1.78% v/v H ₃ PO ₄ , 15:1 LSR at 140°C for 30 min	62.3 g/100 g	
	Two-stage: treatment with NH ₄ OH at 120°C temperature for 15 min followed by treatment with H ₃ PO ₄ at 140°C for 30 min	71.6 g/100 g	

LSR, liquid-to-solid ratio.

EFB of oil palm [52]. Subsequent enzymatic hydrolysis using microwave irradiation (microwave-assisted enzymatic reaction) at 100 W output power, temperature of 41°C-45°C, and incubation of 4 h was shown to have a profound influence on the yield of reducing sugar (411 mg g⁻¹ of treated EFB biomass) compared to non-microwave enzymatic hydrolysis (178 mg g⁻¹ of treated EFB biomass, after the incubation period of 48 h). Intanakul et al. [53] observed that microwave pretreatment (240 W, 10 min, at atmospheric pressure) enhances the removal of hemicellulose and lignin from cellulose in rice straw and bagasse. The key factor for separation was found to be high temperature (175°C-210°C) in the medium, which was achieved through microwave irradiation without a high pressure build up. Substantial reduction (up to 64%) of hemicellulose content and a moderate reduction (15%-17%) of lignin content were observed in oil palm trunk and oil palm frond lignocellulosic biomass after a microwave-alkali pretreatment method [54].

Microwave-assisted pretreatment of kenaf with 2% or 5% alkali (NaOH) was shown to be effective in delignification and decrystallization of fibers, and contributed to making the kenaf pulp more amenable to cellulase activity [55]. Microwave-assisted alkali irradiation has been reported to be an efficient pretreatment method to enhance cashew apple bagasse digestibility [56]. Tseng et al. [57] used the Taguchi method for statistical optimization of microwave-based heating of cellulosic biomass. This eight-order auto-regressive eXogeneous model helped to increase heating efficiency and reduce pretreatment time. Microwave-assisted KOH pretreatment (400 W for 30 min) significantly removed the recalcitrance of bamboo with low levels of fermentation inhibitors compared to acid pretreatment [58]. Selective delignifying capability of the H₂O₂-activated ammonium molybdate system energized by microwave radiation was reported [59]. In this study, a maximum sugar yield of 59.5% was reported by microwave irradiation of beech wood at 140°C for

30 min, while external heating in an autoclave gave a sugar yield of 41.8%. The study also highlighted the effects of (peroxo) metal complexes as a microwave sensitizer and a delignifying agent for pretreatment of woody biomass.

Microwave irradiation was shown to enhance the dissolution of lignocellulosic materials in ionic liquids and subsequent fractionation of cellulose and lignin [60,61]. Microwave irradiation can facilitate the pretreatment of cellulose in ionic liquids [62].

5.3. Microwave-assisted two-stage pretreatment

Recently, better monomeric sugar release was reported from Kans grass (*Saccharum spontaneum*) and Giant reed (*Arundo donax*) upon two-stage microwave pretreatment (microwave/NaOH pretreatment followed by microwave/H₂SO₄ pretreatment) [63]. The reported results are shown in Table 4. Impressively high sugar yields were reported from *Miscanthus sinensis* by the two-stage pretreatment consisting of microwave-assisted ammonia and phosphoric acid treatments [64]. The reported results are shown in Table 5. In a two-stage pretreatment, overall reduced sugar yield of 0.83 g/g dry biomass was reported upon microwave-alkali followed by acid pretreatment. However, with isolated treatments, fermentable sugar yield of 0.665 g/g and 0.249 g/g dry biomass was observed using microwave-alkali and microwave-acid pretreatments, respectively [44].

Microwave-assisted NaOH pretreatment effectively removed approximately 85% of lignin content in Mission grass (*Pennisetum polystachyon*), using 3% (w/v) NaOH, and 15:1 liquid-to-solid ratio (LSR) at 120°C temperatures for 10 min. As a result, in the subsequent second stage, release of impressively high fermentable sugar content (34.3 ± 1.3 g per 100 g of dried biomass) upon microwave-assisted H₂SO₄ pretreatment was reported using 1% (w/v) H₂SO₄, and 15:1 LSR at 200°C temperature for

a very short pretreatment time (5 min) [65]. In the aforementioned study, the total monomeric sugar yield obtained via the two-stage microwave/chemical process was 40.9 g per 100 g of dried biomass.

5.4. Microwave-assisted organosolvlysis

Organosolvlysis is a potential delignification process for the production of bioethanol from woody biomass. Microwave-assisted organosolvlysis in aqueous glycerol with organic and inorganic acids has been studied using Japanese cedar wood [66]. The pulp obtained by organosolvlysis with 0.1% hydrochloric acid (pK_a -6) at 180°C for 6 min has been shown to produce the highest sugar yield of 53.1%, based on the weight of the original biomass. Whereas with other acids such as phosphoric acid or malonic acid having a lower pK_a value, a lower sugar yield was obtained.

5.5. Using microwave plasmas

Plasma sources are widely investigated as tools for biomass conversion. Atmospheric pressure, non-equilibrium plasmas have also been employed to treat different types of biomass in order to modify their surface and structure properties [67]. To separate the cellulose from the lignin-hemicellulose complex in biomass, plasma pretreatment (using flowing afterglow instead of direct exposure to the discharge plasma) has been applied. This results in increased contact surface and eventually improves the bioethanol production process [68-70]. For sugarcane bagasse pretreatment, a 2.45 GHz microwave plasma torch operating at atmospheric pressure in Ar-steam-air mixtures and in pure air plasmas was applied [71]; significant surface modification and destruction of the lignin layer due to plasma etching effect were observed. Zanini et al. [72] applied cold Ar plasma treatments in order to modify the structure of lignocellulosic fibers, and found that the chemical structure of lignin can be heavily modified by the plasma treatment. Microwave generated plasmas at atmospheric pressure have several advantages compared with those created by dc and RF electric fields: microwave discharges en-

able better energy transfer to the plasma, the microwave-plasma coupling efficiency is nearly 100%, power consumption is potentially lower, and allow throughput atmospheric processing is possible [73]. Recently, a microwave ‘tornado’-type air-water plasma source (Fig. 5) operating at 2.45 GHz and atmospheric pressure has been applied for pretreatment of cellulosic material [67]; the air-water highly reactive plasma environment provides a number of long-lived active species that are able to destroy the cellulosic wrapping. Oxygen containing reactive species such as O_2 ($a^1 \Delta_g$) singlet delta molecules, OH radicals, HNO_2 , and NO_2 have been shown to play important roles in the treatment process.

6. Effect on Subsequent Enzymatic Hydrolysis

Positive effects of microwave pretreatment on subsequent enzymatic hydrolysis have been reported. An increase in initial enzymatic hydrolysis rate of rice straw was observed after pretreatment by combining microwave irradiation with alkali; however, the hydrolysis yield remained unchanged [74]. Compared to other methods, microwave-assisted alkali pretreatment has been shown to be an efficient way to improve the enzymatic hydrolysis accessibility of corncob in a shorter amount of time and at a lower temperature; a total sugar concentration of 683.97 mg/g (or 45.60 g L⁻¹) of pretreated corncob was obtained from the optimum pretreatment conditions of 2% NaOH at 100°C for 30 min in a microwave oven [75]. Microwave-assisted KOH pretreatment yielded improvement of enzymatic hydrolysis of 8.7-fold (20.87%, glucose) and 20.5-fold (63.06%, xylose), respectively, at 48 h compared with untreated bamboo (2.41%, glucose; 2.94%, xylose) with a cellulase concentration of 15 FPU/g glucan [58]. Microwave-assisted dilute acid pretreatment has shown remarkable effects in promoting enzymatic saccharification of water hyacinth; the use of pretreatment conditions of 1% H_2SO_4 at 140°C for 15 min followed by enzymatic hydrolysis yielded a maximum sugar reduction of 48.3 g/100 g, which accounts for 94.6% of the theoretical reduced sugar yield [76].

Drastic enhancement of the enzymatic hydrolysis of cellulose after microwave pretreatment of lignocellulosic material in ionic liquids was recently reported [77]. In this study, the cellulose saccharification percentage was approximately 20% for kenaf powders pretreated in choline formate, choline acetate, and choline propionate by conventional heating at 110°C for 20 min. In contrast, approximately 60%-90% of cellulose was hydrolyzed to glucose after microwave pretreatment in the same ionic liquids at 110°C for 20 min. The rate of enzymatic hydrolysis of cotton cellulose was increased 50-fold after ionic liquid dissolution pretreatment with microwave irradiation [78].

7. Conclusions and Recommendations

It can be concluded that emerging microwave-assisted pretreatment technologies are more efficient, rapid, and economically feasible for effective removal of hemicelluloses and lignin cover compared to their predecessors. A high capital investment is required for microwave equipment; however, the operating costs are lower compared to conventional heating methods or

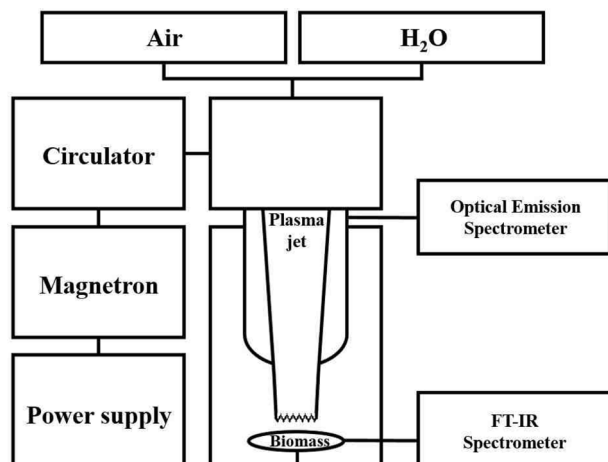

Fig. 5. Block diagram of air-water ‘tornado’-type microwave plasmas for biomass treatment (based on experimental setup by Bundaleska et al. [67]).

systems.

Adequate moisture in biomass feedstock is a key factor for successful biomass pretreatment using microwaves. In the case of woody biomass, steam-induced explosions inside the biomass structure due to high-powered microwave irradiation may increase the recalcitrance of the biomass as such explosions are usually accompanied by a rapid loss of moisture. Therefore, systems that can maintain a sufficient moisture level are recommended for superior pretreatment [79]. In addition, the use of pressurized reactors has been recommended since insignificant breakdown was observed under atmospheric pressure conditions, where temperatures of only $\pm 100^\circ\text{C}$ could be achieved.

Conflict of Interest

No potential conflict of interest relevant to this article was reported.

References

- [1] Mosier N, Wyman C, Dale B, Elander R, Lee YY, Holtzapple M, Ladisch M. Features of promising technologies for pretreatment of lignocellulosic biomass. *Bioresour Technol*, **96**, 673 (2005). <http://dx.doi.org/10.1016/j.biortech.2004.06.025>.
- [2] Kumar P, Barrett DM, Delwiche MJ, Stroeve P. Methods for pretreatment of lignocellulosic biomass for efficient hydrolysis and biofuel production. *Ind Eng Chem Res*, **48**, 3713 (2009). <http://dx.doi.org/10.1021/ie801542g>.
- [3] Biomass pre-treatment: separation of cellulose, hemicellulose and treatment: separation of cellulose, hemicellulose and lignin. Existing technologies and perspectives. Available from: http://www.eurobioref.org/Summer_School/Lectures_Slides/day2/Lectures/L04_AG%20Raspolli.pdf.
- [4] Allen SJ, Koumanova B, Kircheva Z, Nenkova S. Adsorption of 2-nitrophenol by technical hydrolysis lignin: Kinetics, Mass Transfer, and Equilibrium Studies. *Ind Eng Chem Res*, **44**, 2281 (2005). <http://dx.doi.org/10.1021/ie049455d>.
- [5] Cagnon B, Py X, Guillot A, Stoeckli F, Chambat G. Contributions of hemicellulose, cellulose and lignin to the mass and the porous properties of chars and steam activated carbons from various lignocellulosic precursors. *Bioresour Technol*, **100**, 292 (2009). <http://dx.doi.org/10.1016/j.biortech.2008.06.009>.
- [6] Nor NM, Lau LC, Lee KT, Mohamed AR. Synthesis of activated carbon from lignocellulosic biomass and its applications in air pollution control: a review. *J Environ Chem Eng*, **1**, 658 (2013). <http://dx.doi.org/10.1016/j.jece.2013.09.017>.
- [7] Ioannidou O, Zabaniotou A. Agricultural residues as precursors for activated carbon production: a review. *Renewable Sustainable Energy Rev*, **11**, 1966 (2007). <http://dx.doi.org/10.1016/j.rser.2006.03.013>.
- [8] Sethupathi S, Bashir MJK, Akbar ZA, Mohamed AR. Biomass-based palm shell activated carbon and palm shell carbon molecular sieve as gas separation adsorbents. *Waste Manag Res*, **33**, 303 (2015). <http://dx.doi.org/10.1177/0734242X15576026>.
- [9] Sun L, Tian C, Li M, Meng X, Wang L, Wang R, Yin J, Fu H. From coconut shell to porous graphene-like nanosheets for high-power supercapacitors. *J Mater Chem A*, **1**, 6462 (2013). <http://dx.doi.org/10.1039/c3ta10897j>.
- [10] Parshetti GK, Chowdhury S, Balasubramanian R. Plant derived porous graphene nanosheets for efficient CO₂ capture. *RSC Adv*, **4**, 44634 (2014). <http://dx.doi.org/10.1039/c4ra05522e>.
- [11] Shams SS, Zhang LS, Hu R, Zhang R, Zhu J. Synthesis of graphene from biomass: a green chemistry approach. *Mater Lett*, **161**, 476 (2015). <http://dx.doi.org/10.1016/j.matlet.2015.09.022>.
- [12] Ogura K, Ninomiya K, Takahashi K, Ogino C, Kondo A. Pretreatment of Japanese cedar by ionic liquid solutions in combination with acid and metal ion and its application to high solid loading. *Biotechnol Biofuels*, **7**, 120 (2014). <http://dx.doi.org/10.1186/s13068-014-0120-z>.
- [13] Brodeur G, Yau E, Badal K, Collier J, Ramachandran KB, Ramakrishnan S. Chemical and physicochemical pretreatment of lignocellulosic biomass: a review. *Enzyme Res*, **2011**, **1** (2011). <http://dx.doi.org/10.4061/2011/787532>.
- [14] Hsu TA, Ladisch MR, Tsao GT. Alcohol from cellulose. *Chemtech*, **10**, 315 (1980).
- [15] Zhang YHP, Ding SY, Mielenz JR, Cui JB, Elander RT, Laser M, Himmel ME, McMillan JR, Lynd LR. Fractionating recalcitrant lignocellulose at modest reaction conditions. *Biotechnol Bioeng*, **97**, 214 (2007). <http://dx.doi.org/10.1002/bit.21386>.
- [16] Pretreatment of lignocellulosic biomass. Available from: http://www.oardc.ohio-state.edu/beems/images/BEEMS_B1_Biomass_prertreatment.pdf.
- [17] da Silva ASA, Inoue H, Endo T, Yano S, Bon EPS. Milling pretreatment of sugarcane bagasse and straw for enzymatic hydrolysis and ethanol fermentation. *Bioresour Technol*, **101**, 7402 (2010). <http://dx.doi.org/10.1016/j.biortech.2010.05.008>.
- [18] Varga E, Réczey K, Zacchi G. Optimization of steam pretreatment of corn stover to enhance enzymatic digestibility. *Appl Biochem and Biotechnol*, **114**, 509 (2004). <http://dx.doi.org/10.1385/ABAB:114:1-3:509>.
- [19] Hsu TC, Guo GL, Chen WH, Hwang WS. Effect of dilute acid pretreatment of rice straw on structural properties and enzymatic hydrolysis. *Bioresour Technol*, **101**, 4907 (2010). <http://dx.doi.org/10.1016/j.biortech.2009.10.009>.
- [20] Wan C, Li Y. Microbial pretreatment of corn stover with *Ceriporiopsis subvermispora* for enzymatic hydrolysis and ethanol production. *Bioresour Technol*, **101**, 6398 (2010). <http://dx.doi.org/10.1016/j.biortech.2010.03.070>.
- [21] Alinia R, Zabihi S, Esmailzadeh F, Kalajahi JF. Pretreatment of wheat straw by supercritical CO₂ and its enzymatic hydrolysis for sugar production. *Biosyst Eng*, **101**, 61 (2010). <http://dx.doi.org/10.1016/j.biosystemseng.2010.07.002>.
- [22] Zhu S, Wu Y, Yu Z, Chen Q, Wu G, Yu F, Wang C, Jin S. Microwave-assisted alkali pre-treatment of wheat straw and its enzymatic hydrolysis. *Biosyst Eng*, **94**, 437 (2006). <http://dx.doi.org/10.1016/j.biosystemseng.2006.04.002>.
- [23] Ma F, Yang N, Xu C, Yu H, Wu J, Zhang X. Combination of biological pretreatment with mild acid pretreatment for enzymatic hydrolysis and ethanol production from water hyacinth. *Bioresour Technol*, **101**, 9600 (2010). <http://dx.doi.org/10.1016/j.biortech.2010.07.084>.
- [24] Saratale GD, Oh SE. Lignocellulosics to ethanol: the future of the chemical and energy industry. *Afr J Biotechnol*, **11**, 1002 (2012). <http://dx.doi.org/10.5897/AJB10.897>.
- [25] Kumar R, Singh S, Singh OV. Bioconversion of lignocellulosic biomass: biochemical and molecular perspectives. *J Ind Microbiol*

- Biotechnol, **35**, 377 (2008). <http://dx.doi.org/10.1007/s10295-008-0327-8>.
- [26] Saratale GD, Chen SD, Lo YC, Saratale RG, Chang JS. Outlook of biohydrogen production from lignocellulosic feedstock using dark fermentation: a review. *J Sci Ind Res*, **67**, 962 (2008).
- [27] Zhang YHP, Berson E, Sarkanen S, Dale BE. Sessions 3 and 8: Pretreatment and biomass recalcitrance: fundamentals and progress. *Appl Biochem Biotechnol*, **153**, 80 (2009). <http://dx.doi.org/10.1007/s12010-009-8610-3>.
- [28] McMillan JD. Pretreatment of lignocellulosic biomass. *ACS Symp Ser*, **566**, 292 (1994). <http://dx.doi.org/10.1021/bk-1994-0566.ch015>.
- [29] Alvira P, Tomás-Pejó E, Ballesteros M, Negro MJ. Pretreatment technologies for an efficient bioethanol production process based on enzymatic hydrolysis: a review. *Bioresour Technol*, **101**, 4851 (2010). <http://dx.doi.org/10.1016/j.biortech.2009.11.093>.
- [30] Lynd LR, Elamder RT, Wyman CE. Likely features and costs of mature biomass ethanol technology. *Appl Biochem Biotechnol*, **57**, 741 (1996). <http://dx.doi.org/10.1007/BF02941755>.
- [31] Yang B, Wyman CE. Pretreatment: the key to unlocking low-cost cellulosic ethanol. *Biofuels Bioprod Biorefin*, **2**, 26 (2008). <http://dx.doi.org/10.1002/bbb.49>.
- [32] Roberts BA, Strauss CR. Scale-up of Microwave-Assisted Organic Synthesis. In: Tierney JP, Lidström P, eds. *Microwave Assisted Organic Synthesis*, Blackwell, Oxford, 237 (2005).
- [33] Surati MA, Jauhari S, Desai KR. A brief review: microwave assisted organic reaction. *Arch Appl Sci Res*, **4**, 645 (2012).
- [34] Xiong J, Ye J, Liang WZ, Fan PM. Influence of microwave on the ultrastructure of cellulose. *J South China Univ Technol*, **28**, 84 (2000).
- [35] Gabhane J, William SPMP, Vaidya AN, Mahapatra K, Chakrabarti T. Influence of heating source on the efficacy of lignocellulosic pretreatment: a cellulosic ethanol perspective. *Biomass Bioenergy*, **35**, 96 (2011). <http://dx.doi.org/10.1016/j.biombioe.2010.08.026>.
- [36] Datta AK. Fundamentals of Heat and Moisture Transport for Microwaveable Food Product and Process Development. In: Datta AK, Anantheswaran RC, eds. *Handbook of Microwave Technology for Food Applications*, Marcel Dekker, New York, NY, 115 (2001).
- [37] de la Hoz A, Díaz-Ortiz A, Moreno A. Microwaves in organic synthesis: thermal and non-thermal microwave effects. *Chem Soc Rev*, **34**, 164 (2005). <http://dx.doi.org/10.1039/B411438H>.
- [38] Keshwani DR, Cheng JJ. Microwave-based alkali pretreatment of switchgrass and coastal bermudagrass for bioethanol production. *Biotechnol Prog*, **26**, 644 (2010). <http://dx.doi.org/10.1002/btpr.371>.
- [39] Verma A, Kumar S, Jain PK. Key pretreatment technologies on cellulosic ethanol production. *J Sci Res Banaras Hindu Univ*, **55**, 57 (2011).
- [40] Chen WH, Tu YJ, Sheen HK. Disruption of sugarcane bagasse lignocellulosic structure by means of dilute sulfuric acid pretreatment with microwave-assisted heating. *Appl Energy*, **88**, 2726 (2011). <http://dx.doi.org/10.1016/j.apenergy.2011.02.027>.
- [41] Ooshima H, Aso K, Harano Y, Yamamoto T. Microwave treatment of cellulosic materials for their enzymatic hydrolysis. *Biotechnol Lett*, **6**, 289 (1984). <http://dx.doi.org/10.1007/BF00129056>.
- [42] Peng H, Li H, Luo H, Xu J. A novel combined pretreatment of ball milling and microwave irradiation for enhancing enzymatic hydrolysis of microcrystalline cellulose. *Bioresour Technol*, **130**, 81 (2013). <http://dx.doi.org/10.1016/j.biortech.2012.10.167>.
- [43] Azuma JI, Tanaka F, Koshijima T. Enhancement of enzymatic susceptibility of lignocellulosic wastes by microwave irradiation. *J Ferment Technol*, **62**, 377 (1984).
- [44] Binod P, Satyanagalakshmi K, Sindhu R, Janu KU, Sukumaran RK, Pandey A. Short duration microwave assisted pretreatment enhances the enzymatic saccharification and fermentable sugar yield from sugarcane bagasse. *Renew Energy*, **37**, 109 (2012). <http://dx.doi.org/10.1016/j.renene.2011.06.007>.
- [45] Ravooof SA, Pratheepa K, Supassri T, Chittibabu S. Enhancing enzymatic hydrolysis of rice straw using microwave assisted nitric acid pretreatment. *Int J Med Biosci*, **1**, 13 (2012).
- [46] Zhu S, Wu Y, Yu Z, Liao J, Zhang Y. Pretreatment by microwave/alkali of rice straw and its enzymic hydrolysis. *Process Biochem*, **40**, 3082 (2005). <http://dx.doi.org/10.1016/j.procbio.2005.03.016>.
- [47] Zhu S, Wu Y, Yu Z, Zhang X, Wang C, Yu F, Jin S. Production of ethanol from microwave-assisted alkali pretreated wheat straw. *Process Biochem*, **41**, 869 (2006). <http://dx.doi.org/10.1016/j.procbio.2005.10.024>.
- [48] Xu J, Chen H, Kádár Z, Thomsen AB, Schmidt JE, Peng H. Optimization of microwave pretreatment on wheat straw for ethanol production. *Biomass Bioenergy*, **35**, 3859 (2011). <http://dx.doi.org/10.1016/j.biombioe.2011.04.054>.
- [49] Ethaib S, Omar R, Kamal SMM, Biak DRA. Microwave-assisted pretreatment of lignocellulosic biomass: a review. *J Eng Sci Technol*, **10**, 97 (2015).
- [50] Hu Z, Wen Z. Enhancing enzymatic digestibility of switchgrass by microwave-assisted alkali pretreatment. *Biochem Eng J*, **38**, 369 (2008). <http://dx.doi.org/10.1016/j.bej.2007.08.001>.
- [51] Chittibabu S, Rajendran K, Santhanmuthu M, Saseetharan MK. Optimization of microwave assisted alkali pretreatment and enzymatic hydrolysis of Banana pseudostem for bioethanol production. *Proceedings of the 2nd International Conference on Environmental Science and Technology IPCBEE, Singapore*, V2-67 (2011).
- [52] Nomanbhay SM, Hussain R, Palanisamy K. Microwave-assisted alkaline pretreatment and microwave assisted enzymatic saccharification of oil palm empty fruit bunch fiber for enhanced fermentable sugar yield. *J Sustainable Bioenergy Syst*, **3**, 7 (2013). <http://dx.doi.org/10.4236/jsbs.2013.31002>.
- [53] Intanakula P, Krairikshb M, Kitchaiya P. Enhancement of enzymatic hydrolysis of lignocellulosic wastes by microwave pretreatment under atmospheric pressure. *J Wood Chem Technol*, **23**, 217 (2003). <http://dx.doi.org/10.1081/WCT-120021926>.
- [54] Lai LW, Idris A. Disruption of oil palm trunks and fronds by microwave-alkali pretreatment. *Bioresources*, **8**, 2792 (2013).
- [55] Ooi BG, Rambo AL, Hurtado MA. Overcoming the recalcitrance for the conversion of kenaf pulp to glucose via microwave-assisted pre-treatment processes. *Int J Mol Sci*, **12**, 1451 (2011). <http://dx.doi.org/10.3390/ijms12031451>.
- [56] Rodrigues THS, Rocha MVP, de Macedo GR, Gonçalves LRB. Ethanol production from cashew apple bagasse: improvement of enzymatic hydrolysis by microwave-assisted alkali pretreatment. *Appl Biochem Biotechnol*, **164**, 929 (2011). <http://dx.doi.org/10.1007/s12010-011-9185-3>.
- [57] Tseng KH, Shiao YF, Chang RF, Yeh YT. Optimization of microwave-based heating of cellulosic biomass using Taguchi method. *Materials*, **6**, 3404 (2013). <http://dx.doi.org/10.3390/ma6083404>.
- [58] Li Z, Jiang Z, Fei B, Yu Y, Cai Z. Effective of Microwave-KOH

- Pretreatment on enzymatic hydrolysis of bamboo. *J Sustainable Bioenergy Syst*, **2**, 104 (2012). <http://dx.doi.org/10.4236/jsbs.2012.24015>.
- [59] Verma P, Watanabe T, Honda Y, Watanabe T. Microwave-assisted pretreatment of woody biomass with ammonium molybdate activated by H₂O₂. *Bioresour Technol*, **102**, 3941 (2011). <http://dx.doi.org/10.1016/j.biortech.2010.11.058>.
- [60] Wang X, Li H, Cao Y, Tang Q. Cellulose extraction from wood chip in an ionic liquid 1-allyl-3-methylimidazolium chloride (AmimCl). *Bioresour Technol*, **102**, 7959 (2011). <http://dx.doi.org/10.1016/j.biortech.2011.05.064>.
- [61] Wang H, Maxim ML, Gurau G, Rogers RD. Microwave-assisted dissolution and delignification of wood in 1-ethyl-3-methylimidazolium acetate. *Bioresour Technol*, **136**, 739 (2013). <http://dx.doi.org/10.1016/j.biortech.2013.03.064>.
- [62] Li L, Yu ST, Liu FS, Xie CX, Xu CZ. Efficient enzymatic in situ saccharification of cellulose in aqueous-ionic liquid media by microwave pretreatment. *BioResources*, **6**, 4494 (2011).
- [63] Komolwanich T, Tatijareen P, Prasertwasu S, Khumsupan D, Chaisuwan T, Luengnaruemitchai A, Wongkasemjit S. Comparative potentiality of Kans grass (*Saccharum spontaneum*) and Giant reed (*Arundo donax*) as lignocellulosic feedstocks for the release of monomeric sugars by microwave/chemical pretreatment. *Cellulose*, **21**, 1327 (2014). <http://dx.doi.org/10.1007/s10570-013-0161-7>.
- [64] Boonmanumsin P, Treeboobpha S, Jeamjumnunja K, Luengnaruemitchai A, Chaisuwan T, Wongkasemjit S. Release of monomeric sugars from *Miscanthus sinensis* by microwave-assisted ammonia and phosphoric acid treatments. *Bioresour Technol*, **103**, 425 (2012). <http://dx.doi.org/10.1016/j.biortech.2011.09.136>.
- [65] Tatijareen P, Prasertwasu S, Komolwanich T, Chaisuwan T, Luengnaruemitchai A, Wongkasemjit S. Capability of Thai Mission grass (*Pennisetum polystachyon*) as a new weedy lignocellulosic feedstock for production of monomeric sugar. *Bioresour Technol*, **143**, 423 (2013). <http://dx.doi.org/10.1016/j.biortech.2013.05.128>.
- [66] Liu J, Takada R, Karita S, Watanabe T, Honda Y, Watanabe T. Microwave-assisted pretreatment of recalcitrant softwood in aqueous glycerol. *Bioresour Technol*, **101**, 9355 (2010). <http://dx.doi.org/10.1016/j.biortech.2010.07.023>.
- [67] Bundaleska N, Tatarova E, Dias FM, Lino da Silva M, Ferreira CM, Amorim J. Air-water 'tornado'-type microwave plasmas applied for sugarcane biomass treatment. *J Phys D Appl Phys*, **47**, 055201 (2013). <http://dx.doi.org/10.1088/0022-3727/47/5/055201>.
- [68] Karahan HA, Özdoğan E. Improvements of surface functionality of cotton fibers by atmospheric plasma treatment. *Fibers Polym*, **9**, 21 (2008). <http://dx.doi.org/10.1007/s12221-008-0004-6>.
- [69] Vander Wielen LC, Elder T, Ragauskas AJ. Analysis of the topochemical effects of dielectric-barrier discharge on cellulosic fibers. *Cellulose*, **12**, 185 (2005). <http://dx.doi.org/10.1007/s10570-004-2785-0>.
- [70] Vander Wielen LC, Östenson M, Gatenholm P, Ragauskas AJ. Surface modification of cellulosic fibers using dielectric-barrier discharge. *Carbohydr Polym*, **65**, 179 (2006). <http://dx.doi.org/10.1016/j.carbpol.2005.12.040>.
- [71] Bundaleska N, Saavedra R, Tatarova E, Dias FM, Ferreira CM, Amorim J. Pretreatment of sugarcane biomass by atmospheric pressure microwave plasmas. *Proceedings of ESCAMPIG XXI*, Viana do Castelo, Portugal, 2012.
- [72] Zanini S, Riccardi C, Canevali C, Orlandi M, Zoia L, Tolppa EL. Modifications of lignocellulosic fibers by Ar plasma treatments in comparison with biological treatments. *Surf Coat Technol*, **200**, 556 (2005). <http://dx.doi.org/10.1016/j.surfcoat.2005.01.090>.
- [73] Moisan M, Zakrzewski Z. Plasma sources based on the propagation of electromagnetic surface waves. *J Phys D Appl Phys*, **24**, 1025 (1991). <http://dx.doi.org/10.1088/0022-3727/24/7/001>.
- [74] Zhu S, Wu Y, Yu Z, Zhang X, Li H, Gao M. The effect of microwave irradiation on enzymatic hydrolysis of rice straw. *Bioresour Technol*, **97**, 1964 (2006). <http://dx.doi.org/10.1016/j.biortech.2005.08.008>.
- [75] Boonsombuti A, Luengnaruemitchai A, Wongkasemjit S. Enhancement of enzymatic hydrolysis of corncob by microwave-assisted alkali pretreatment and its effect in morphology. *Cellulose*, **20**, 1957 (2013). <http://dx.doi.org/10.1007/s10570-013-9958-7>.
- [76] Xia A, Cheng J, Song W, Yu C, Zhou J, Cen K. Enhancing enzymatic saccharification of water hyacinth through microwave heating with dilute acid pretreatment for biomass energy utilization. *Energy*, **61**, 158 (2013). <http://dx.doi.org/10.1016/j.energy.2013.09.019>.
- [77] Ninomiya K, Yamauchi T, Ogino C, Shimizu N, Takahashi K. Microwave pretreatment of lignocellulosic material in cholinium ionic liquid for efficient enzymatic saccharification. *Biochem Eng J*, **90**, 90 (2014). <http://dx.doi.org/10.1016/j.bej.2014.05.013>.
- [78] Ha SH, Mai NL, An G, Koo YM. Microwave-assisted pretreatment of cellulose in ionic liquid for accelerated enzymatic hydrolysis. *Bioresour Technol*, **102**, 1214 (2011). <http://dx.doi.org/10.1016/j.biortech.2010.07.108>.
- [79] New York State Energy Research and Development Authority. Evaluation of microwave pretreatment for reducing the recalcitrance of woody biomass to hemicellulose extraction and cellulose hydrolysis (Report No. 11-11), New York State Energy Research and Development Authority, Albany, NY (2011).