

[Special Paper]

# Sunroof Buffeting Simulation of a Simplified Car Model using PAM-FLOW

## PAM-FLOW를 이용한 단순차량 모델의 썬루프 버페팅 소음 해석

Dong-Guk Lee\*, Il-Kyoo Park\* and Jong-Yun Lim†  
이 동 국 · 박 일 규 · 임 종 윤

(Received November 19, 2013 ; Revised February 26, 2014 ; Accepted February 26, 2014)

**Key Words** : Sunroof(썬루프), Buffeting Noise(버페팅 소음), Benchmark(벤치마크)

### ABSTRACT

This paper presents a benchmark test result of an application of computational fluid dynamics(CFD) analysis of automotive sunroof buffeting simulation. Computational analyses of flow over an open sunroof of a simple vehicle model called as HAWT(Hyundai aeroacoustic wind tunnel) model were performed to study the buffeting phenomenon and to predict the buffeting noise level and its frequency. Computations are performed for sunroofs with PAM-FLOW software which is one of powerful CFD code of ESI group. Numerical predictions are compared with result from the tunnel test measurements. It is shown that CFD analysis has great potential for sunroof design and development by predicting buffeting noise.

### 요 약

이 연구에서는 자동차의 썬루프 버페팅 소음을 해석하기 위해 전산유체역학을 적용한 벤치마크 결과를 제시한다. 현대자동차의 HAWT라 불리는 단순 차량모델에서 열린 썬루프 위로의 유동해석을 통해 버페팅 현상과 그 소음 수준을 모사하였으며, 해석에 사용된 소프트웨어는 ESI Group의 PAM-FLOW이다. 해석결과는 풍동에서의 시험결과와 비교되었으며, 비교적 좋은 상관관계를 얻을 수 있었다. 전산유체해석을 통해 버페팅 소음을 예측함으로써 자동차의 썬루프 설계와 개발에 매우 유용할 것으로 기대된다.

### Nomenclature

$M$  : Mach number  
 $p$  : Pressure  
 $Re$  : Reynolds number  
 $t$  : Time

$\tau_{ij}$  : Strain tensor  
 $u_i$  : Velocity  
 $x_i$  : Displacement in the wind direction

### 1. Introduction

Wind rush and wind buffeting noise are among

† Corresponding Author ; Member, ESI Korea  
E-mail : lly@esi.co.kr  
Tel : +82 -2-3660-4530, Fax: +82-2-3662-0084  
\* ESI Korea

# A part of this paper was presented at the KSNVE 2012 Annual Autumn Conference  
‡ Recommended by Editor-in-Chief Weuibong Jung  
© The Korean Society for Noise and Vibration Engineering

the dominant automotive noise sources of an automotive. Sunroof buffeting is a flow excited resonance phenomenon that usually occurs at low frequency less than 100 Hz. The coupling between the acoustic frequency of the passenger compartment and the periodic instability in the shear layer off the vehicle roof results in the production of high amplitude sound pressure<sup>(1,4)</sup>.

It is involved with the breakup of the shear layer into discrete vortices, convection of the vortices with the flow, interaction of the vortices with the downstream edge of sunroof opening and feedback of acoustic disturbance through the vehicle compartment. This is inherently unsteady flow phenomenon and it includes complex flow physics and poses several challenges for numerical simulations especially compressible fluid characteristic and transient time stepping to capture pressure fluctuation in very short time period.

## 2. Numerical Method

### 2.1 Experimental Setup

PAM-FLOW has two technical schemes to simulate flow induced noise problem. One is low Mach Lighthill - Curle type pressure sound radiation for incompressible solver and the other is weak compressibility approach. In this study, the second method(weak compressibility) was used. This method is a fully coupled approach between the monopole acoustic wave propagation and the incompressible flow Navier-Stokes solution for a low mach flow regime. This regime is not possible to be covered by the compressible flow Euler/Navier-Stokes solutions due to the issue of its stiffness in the solution method. So the “weak compressibility” method for this kind of problem was implemented in PAM-FLOW<sup>(2)</sup>. The governing Eq. (1) assumes that the entropy is constant for the fluid under consideration, as follows.

$$M^2 \left\{ \frac{\partial p}{\partial t} + u_j \frac{\partial p}{\partial x_j} \right\} + \frac{\partial u_j}{\partial x_j} = 0$$

$$\frac{\partial u_i}{\partial t} + \frac{\partial u_j}{\partial x_j} - u_i \frac{\partial u_j}{\partial x_j} = - \frac{\partial p}{\partial x_i} + \frac{\partial \tau_{ij}}{\partial x_j}$$

$$\tau_{ij} = \frac{1}{Re} \left( \frac{\partial u_i}{\partial x_j} + \frac{\partial u_j}{\partial x_i} \right)$$
(1)

where  $x_i$  is the displacement in wind direction,  $t$  is the time,  $p$  is the pressure,  $u_i$  is the velocity component,  $Re$  is the Reynolds number,  $\tau_{i,j}$  is the strain tensor, and  $M$  is the Mach number. The first term is added in this mathematic form as weak compressibility in the incompressible flow mass conservation. The numerical scheme implemented is very similar to the incompressible one in PAM-FLOW<sup>(3)</sup>, in such a way that weak-compressibility terms behave like a correction term with respect to the edge-based finite elements solver for incompressible flows.

## 3. Computational Model

The computational model in Fig. 1 was provided by Hyundai Motors Company(HMC) and they carried out the test of real model to compare with

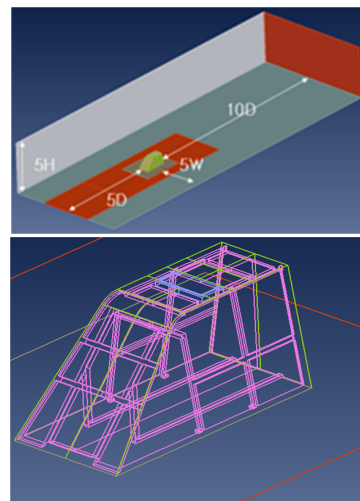

Fig. 1 Simulation domain and its structure

the simulation result. CFD simulation was performed with real scale geometry and same condition as the test.

The simplified model has half scale of real vehicle (2 m in length) and its cavity is surrounded by resilient walls with a lot of frames and absorptive material is attached with them. This compliance effect from the walls wasn't considered but they were treated as rigid and non-absorptive faces.

Computational grid used in this benchmark test is illustrated in Fig. 2.

The model has about 8 million tetrahedral grids and it includes 5 boundary prism layers in 5 mm thickness with 0.2 mm thickness of first boundary layer grid. Also, finer grids were used near the opening area (sunroof) and measuring point (inside of the cabin) to capture the pressure fluctuation. All boundaries except for the ground and vehicle surfaces were treated as an open field.

This computational grid was created by Pre-FLOW application which is a package product of PAM-FLOW.

For the unsteady turbulent model, LES Smagorinsky SGS model was used and incompressible ROE solver for the numerical scheme was used. This numerical scheme uses the ROE flux splitting for the convective terms and an implicit projection two step predictor-corrector time integration scheme. The pressure and the viscous

terms are solved implicitly, while the advective terms are solved explicitly.

#### 4. Simulation Results

The simulation was done by the latest PAM-FLOW version 2009. The speeds of vehicle used for the simulation are 20, 30, 40, 50, 60, 70, 80 and 100 km/h. Each simulation run-time is about 48 hours with 16 core of AMD Opteron 2.0 GHz, for 2 seconds of physical time and each time step is between  $10^{-4}$  and  $10^{-5}$  seconds.

Fig. 3 shows the time histories of the simulated pressure signal in time at the measured point according to each speed.

The pressure fluctuations in the middle velocity range (40~60 km/h) are very periodic while ones in low or high speeds are not so periodic. The time histories were be Hamming-windowed with 8 time segments and 50 % overlapping between time segments before the FFT was applied.

Fig. 4 shows the SPL spectra in each wind speed. The dotted vertical line indicates the acoustical resonance frequency  $f_h = 26.7$  Hz of the model as a Helmholtz resonator. Because the very periodic pressure fluctuations were obtained (Fig. 3) in middle wind speed, their SPL spectra have the result clearly peaked near the resonance frequency like a simple 1-dof resonator while SPL spectra in the other speeds have several peak frequencies.

This benchmark test was conducted as "blind simulation". After the simulation was done, HMC provided the test result of the model. Figure 5 and 6 show the comparison between simulation result and test results with respect to peak frequency and peak SPL according to the wind speeds respectively

The comparison shows that the simulation result of PAM-FLOW has a good agreement with the test in terms of peak frequencies and the reasonable trend of peak sound pressure levels. For the initial grid at 20 km/h speed, the results had too

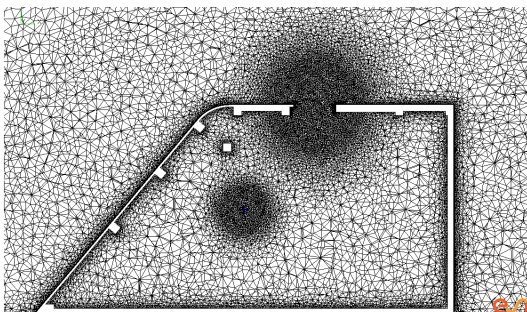

**Fig. 2** Tetrahedral meshes around the 3D cavity with the boundary layer meshes for the HAWT model

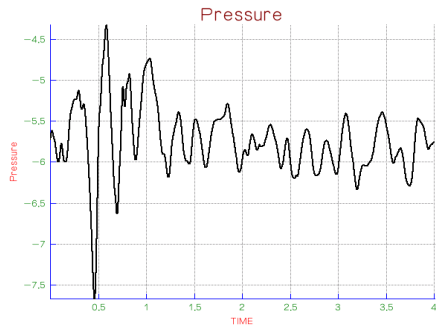

(a) 20 km/h

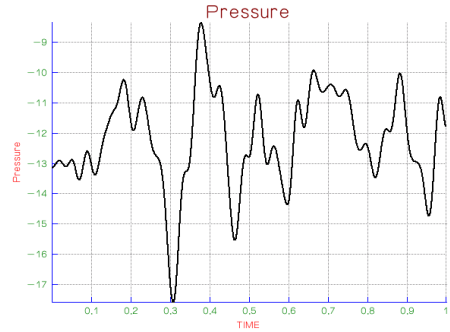

(b) 30 km/h

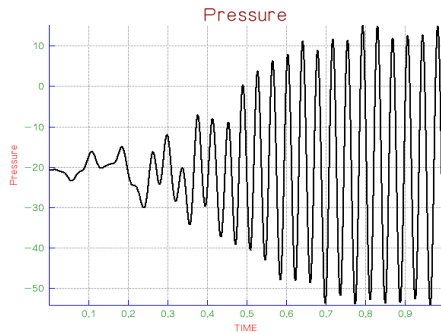

(c) 40 km/h

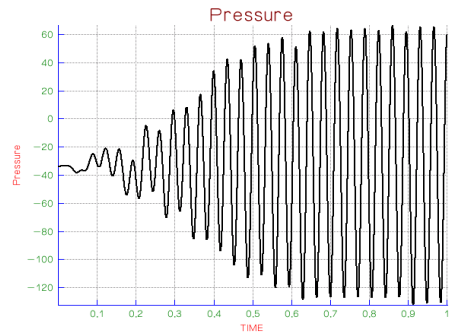

(d) 50 km/h

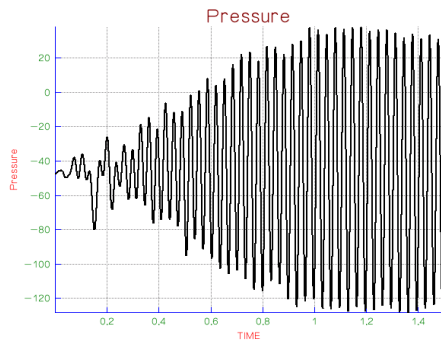

(e) 60 km/h

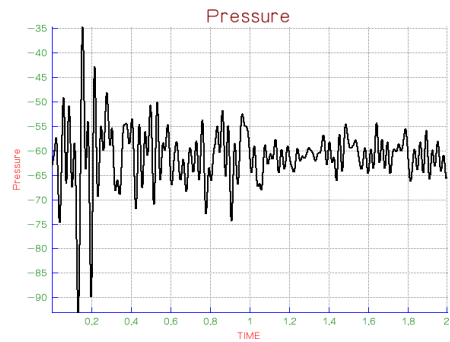

(f) 70 km/h

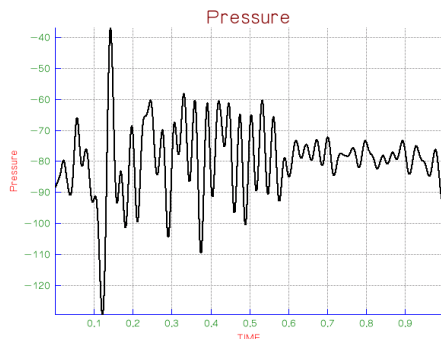

(g) 80 km/h

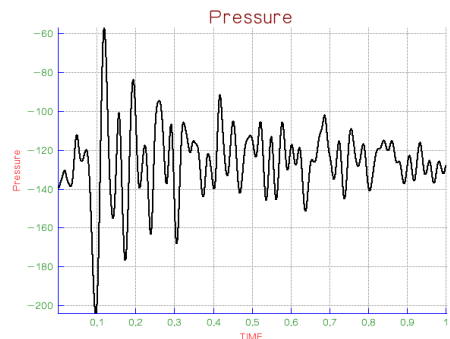

(h) 100 km/h

**Fig. 3** Time histories of pressure at measured point in PAM-FLOW simulation

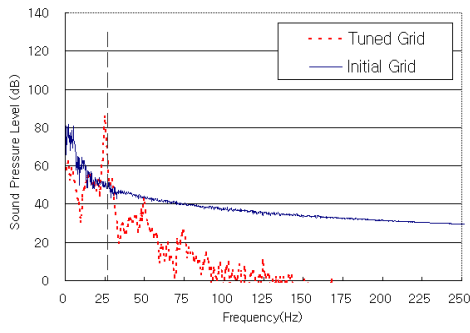

(a) 20 km/h

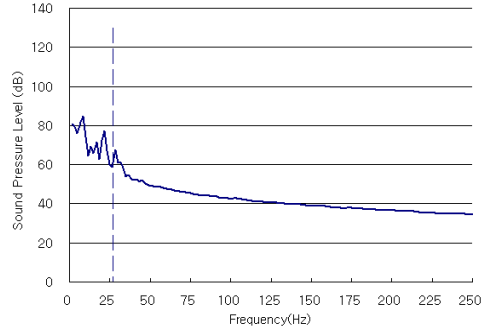

(b) 30 km/h

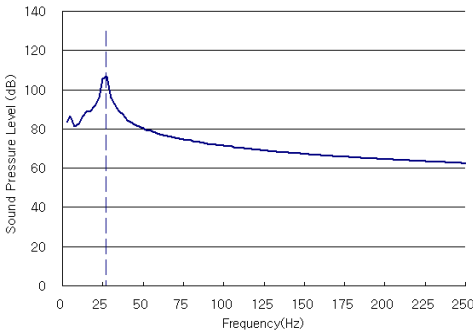

(c) 40 km/h

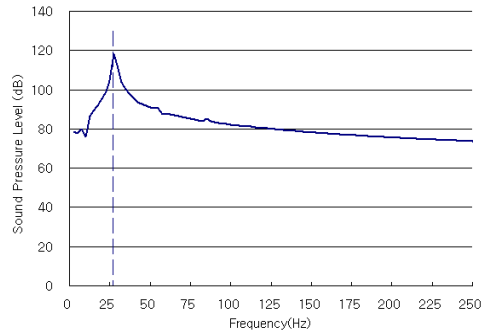

(d) 50 km/h

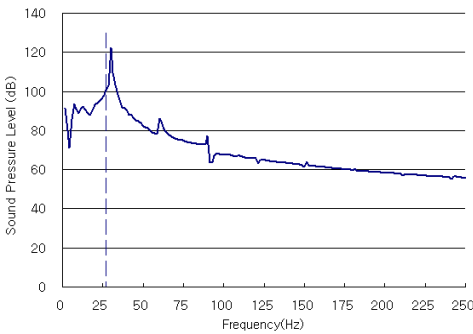

(e) 60 km/h

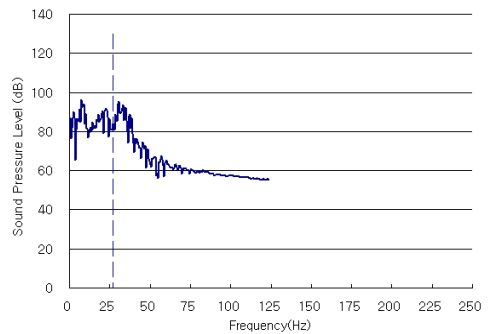

(f) 70 km/h

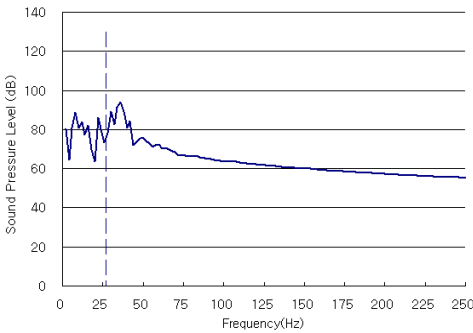

(g) 80 km/h

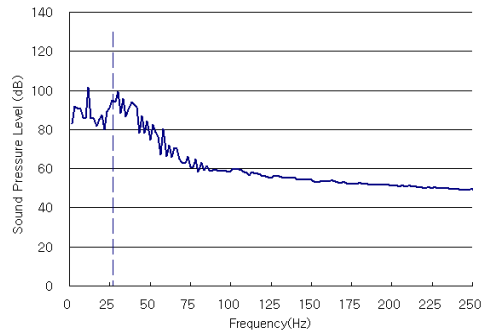

(h) 100 km/h

**Fig. 4** SPL spectra at measured point in PAM-FLOW simulation

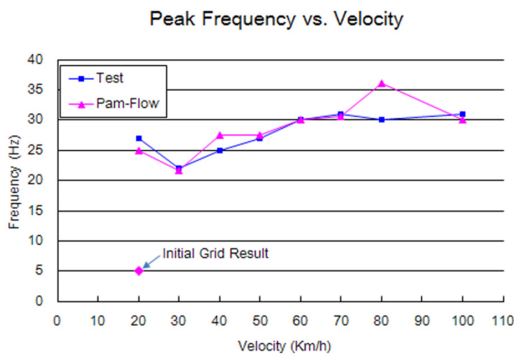

**Fig. 5** Comparison of peak frequency between PAM-FLOW results and test

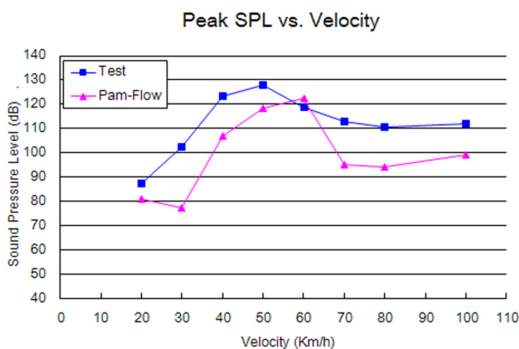

**Fig. 6** Comparison of sound pressure levels between PAM-FLOW results and test

low peak frequency, compared with the result from other speeds. The result was improved by using finer grid, so had also a good agreement with the test. Pressure fluctuations from wind speed 40~60 km/h have very strong and dominant frequency contents at the cavity resonance, so they are similar to pure tone fluctuations, which means that the coupling between flow and cavity is very strong and results in high sound pressure.

Whereas pressure fluctuations from low or high speed have various frequency contents with the cavity resonance, which means that the coupling is relatively small and result in relatively small sound pressure.

However there're several points of discrepancies between simulation result and test results. First, peak frequency at 30 and 80 km/h is higher than

the test result. Second, the magnitude of peak SPL of the simulation result is less than the experimental result. Third one is the speed of the most peak SPL. The identification for these discrepancies requires more investigation and it will be studied in the next study.

#### 4. Concluding Remarks

The simulation result of PAM-FLOW has a good agreement with the experiment in terms of peak frequencies and reasonable trend of peak sound pressure levels. Especially the implemented method in PAM-FLOW has a strong point with respect to both of its accuracy and required hardware consumption because this results were obtained with relatively very small hardware resources compared than other CFD codes.

Since the benchmark test was conducted within very short schedule, so it was not able to carry out enough grid tests, boundary condition configurations. However the first simulation result with very minimum grids and configurations resulted in a good agreement so further work with fine tuning will be studied to figure out and reduce the discrepancies noted in this study.

#### Acknowledgement

At the end of the paper, we express our appreciation to the test team of HMC for preparing this benchmark test and sharing the test results for the improvement of CFD technology.

#### References

- (1) Zhu, M., Tappel, A., Megahed, M., Pierrot, G. and Ravier, P., 2005, A Weak Compressible Flow Solution for Fluid and Air-borne Acoustics Coupled Problems in a Nonlinear System; NAFEMS.
- (2) Singh, R., GM Technical Center, Sunroof Buffeting Simulation using PAM-FLOW.

(3) PAM-FLOW 2006, User's Manual, ESI-Group.

(4) Kook, H. and Mongeau, L., 2002, Analysis of the Periodic Pressure Fluctuations Induced by Flow Over a Cavity, Journal of Sound and Vibration, Vol. 251, No. 5, pp. 823~846.



**Dong-Guk Lee** received B.S. degree from Korea Aviation University in 2006. He is currently a consulting engineer at ESI Korea. His research interests are multi-physics problems using CFD including aero-dynamics.



**Il-Kyoo Park** received M.S. degree from Pukyung National University in 2001. He is currently a CFD technical manager at ESI Korea. His research interests are multi-physics problems using CFD including aero-dynamics.



**Jong-Yun Lim** received M.S. degree from KAIST in 1990. He is currently a vibro-acoustic technical manager at ESI Korea. His research interests are vibro-acoustic simulation using FEA, BEA, SEA & hybrid method.