

Obstacle Avoidance of Mobile Robot Based on Behavior Hierarchy by Fuzzy Logic

Taeseok Jin

Dept. of Mechatronics Engineering, Dongseo University
Jurye-ro 47, Sasan-gu, Busan, 617-716, Korea

Abstract

In this paper, we propose a navigation algorithm for a mobile robot, which is intelligently searching the goal location in unknown dynamic environments using an ultrasonic sensor. Instead of using "sensor fusion" method which generates the trajectory of a robot based upon the environment model and sensory data, "command fusion" method is used to govern the robot motions. The navigation strategy is based on the combination of fuzzy rules tuned for both goal-approach and obstacle-avoidance. To identify the environments, a command fusion technique is introduced, where the sensory data of ultrasonic sensors and a vision sensor are fused into the identification process.

Keywords-mobile robot, command fusion, obstacle avoidance, fuzzy, cost function.

1. INTRODUCTION

An autonomous mobile robot is intelligent robot that performs a given work with sensors by identifying the surrounded environment and reacts on the state of condition by itself instead of human. Unlike general manipulator in a fixed working environment [1], it is required intelligent processing in a flexible and variable working environment. And studies on a fuzzy-rule based control are attractive in the field of autonomous mobile robot. Robust behavior in autonomous robots requires that uncertainty be accommodated by the robot control system. Fuzzy logic is particularly well suited for implementing such controllers due to its capabilities of inference and approximate reasoning under uncertainty. Many fuzzy controllers proposed in the literature utilize a monolithic rule-base structure. That is, the precepts that govern desired system behavior are encapsulated as a single collection of *if-then* rules. In most instances, the rule-base is designed to carry out a single control policy or goal. In order to achieve autonomy, mobile robots must be capable of achieving multiple goals whose priorities may change with time. Thus, controllers should be designed to realize a number of task-achieving behaviors that can be integrated to achieve different control objectives. This requires formulation of a large and complex set of fuzzy rules. In this situation a potential limitation to the utility of the monolithic fuzzy controller becomes apparent. Since the size of complete monolithic rule-bases increases exponentially with the number of input variables [1,7,8], multi-input systems can potentially suffer degradations in real-time response. This is a critical issue for mobile robots operating in dynamic surroundings. *Hierarchical* rule structures can be employed to overcome this limitation by reducing the rate of

increase to linear [1, 2].

This paper describes a hierarchical behavior-based control architecture. It is structured as a hierarchy of fuzzy rule-bases which enables distribution of intelligence amongst special purpose *fuzzy-behaviors*. This structure is motivated by the hierarchical nature of behavior as hypothesized in ethological models. A fuzzy coordination scheme is also described that employs weighted decision making based on contextual behavior activation. Performance is demonstrated by simulation highlighting interesting aspects of the decision making process which arise from behavior interaction [3,4].

In this paper, we present a new approach to design a fuzzy controller for increasing the ability of mobile robot to react to dynamic environment. The obstacle avoidance and trajectory planning are two different topics, which makes the control structure of pursuing two-goal together complex. A primary goal is represented as a cost function and the other goal is properly weighted and combined according to the status of the robot and environment. Fuzzy rules derived from the experts' experiences are applied for the implication of the weights. The proposed control algorithm consists of fuzzy for goal approach, obstacle avoidance and determination of the weights. We also use a sensor fusion method to decide the distance and width of obstacles and avoid them during the navigation [5,6].

First, this paper briefly introduces the operation of each command and the fuzzy controller for navigation system in chapter II. Chapter III explains about behavior hierarchy based on fuzzy logic. In chapter IV, experimental results to verify efficiency of system are shown. Finally, Section V concludes this research work and mentions possible future related work.

2. FUZZY CONTROLLER DESIGN

The proposed fuzzy controller is shown as follows. We define three major navigation goals, i.e., target orientation, obstacle

Manuscript received Jul. 26, 2012; revised Sep. 5, 2012;

accepted Sep. 15, 2012

*Corresponding Author: jints@dongseo.ac.kr

© The Korean Institute of Intelligent Systems. All rights reserved.

avoidance and rotation movement; represent each goal as a cost function. Note that the fusion process has a structure of forming a cost function by combining several cost functions using weights. In this fusion process, we infer each weight of command by the fuzzy algorithm that is a typical artificial intelligent scheme. With the proposed method, the mobile robot navigates intelligently by varying the weights depending on the environment, and selects a final command to keep the minimum variation of orientation and velocity according to the cost function.

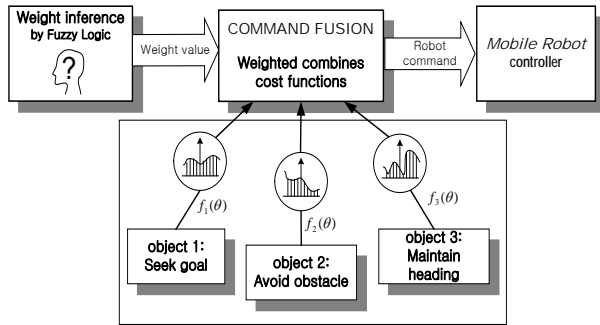

Fig. 1. Overall structure of navigation algorithm

A. Command for towards goal

The orientation command of mobile robot is generated as the nearest direction to the target point. The command is defined as the distance to the target point when the robot moves present with the orientation, θ and the velocity, v . Therefore, a cost function is defined as Eq. (1).

$$E_d(\theta) = \{x_d - x_c + v \cdot \Delta t \cdot \cos \theta\}^2 + \{y_d - (y_c + v \cdot \Delta t \cdot \sin \theta)\}^2 \quad (1)$$

where, v is $v_{\max} - k \cdot |\theta_c - \theta|$ and k represents the reduction ratio of rotational movement.

B. Command for avoiding obstacle

We use the method of representing the cost function for obstacle-avoidance as the shortest distance to an obstacle based upon the sensor data in the form of histogram. The distance information is represented as a form of second order energy, and represented as a cost function by inspecting it about all θ as shown in Eq. (2).

$$E_o(\theta) = d_{\text{sensor}}^2(\theta) \quad (2)$$

To navigate in a dynamic environment to the goal, the mobile robot should recognize the dynamic variation and react to it. For this, the mobile robot extracts the variation of the surrounded environment by comparing the past and the present. For continuous movements of the robot, the transformation matrix of a past frame *w.r.t* the present frame should be defined clearly.

In Fig. 2, a vector, P_{n-1}^α is defined as a position vector of the mobile robot *w.r.t* the $\{n-1\}$ frame and P_n^α is defined as a vector *w.r.t* the $\{n\}$ frame. Then, we obtain the relation between

P_{n-1}^α and P_n^α as follow.

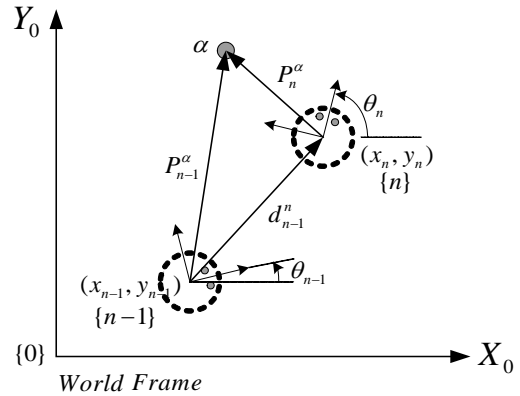

Fig. 2. Transformation of frame

$$P_n^\alpha = R_{n-1}^n (P_{n-1}^\alpha - d_{n-1}^n) \quad (3)$$

Here, R_{n-1}^n is a rotation matrix from $\{n-1\}$ to $\{n\}$ frame defined as Eq. (4), and d_{n-1}^n is a translation matrix from $\{n-1\}$ frame to $\{n\}$ frame as shown in Eq. (5).

$$R_{n-1}^n = \begin{bmatrix} \cos(\Delta\theta) & \sin(\Delta\theta) \\ -\sin(\Delta\theta) & \cos(\Delta\theta) \end{bmatrix} \quad (4)$$

where $\Delta\theta = \theta_n - \theta_{n-1}$

$$d_{n-1}^n = \begin{bmatrix} \cos \theta_{n-1} & \sin \theta_{n-1} \\ -\sin \theta_{n-1} & \cos \theta_{n-1} \end{bmatrix} \begin{bmatrix} x_n - x_{n-1} \\ y_n - y_{n-1} \end{bmatrix} \quad (5)$$

According to the Eq. (3), the environment information measured in the $\{n-1\}$ frame can be represented *w.r.t* the $\{n\}$ frame. Thus, if W_{n-1} , and W_n are the environment information in the polar coordinates measured in $\{n-1\}$ and $\{n\}$ frames, respectively, we can represent W_{n-1} *w.r.t* the $\{n\}$ frame, and extract the moving object by the Eq. (6) in the $\{n\}$ frame.

$$\text{movement} = {}^nW_{n-1} \cdot ({}^nW_{n-1} - W_n) \quad (6)$$

where, ${}^nW_{n-1}$ represents W_{n-1} transformed into the $\{n\}$ frame.

C. Command for minimizing rotation

Minimizing rotational movement aims to rotate wheels smoothly by restraining the rapid motion. The cost function is defined as minimum at the present orientation and is defined as a second order function in terms of the rotation angle, θ as Eq. (7).

$$E_r(\theta) = (\theta_c - \theta)^2 \quad \theta_c : \text{present angle} \quad (7)$$

The command represented as the cost function has three different goals to be satisfied at the same time. Each goal differently contributes to the command by a different weight, as shown in Eq. (8).

$$E(\theta) = w_1 \cdot E_d(\theta) + w_2 \cdot E_o(\theta) + w_3 \cdot E_r(\theta) \quad (8)$$

3. BEHAVIOR HIERARCHY BY FUZZY LOGIC

Primitive behaviors are low-level behaviors that typically take inputs from the robot’s sensors and send outputs to the robot’s actuator forming a nonlinear mapping between them. Composite behaviors map between sensory input and/or global constraints and the Degree of Applicability(DOA) of relevant primitive behaviors [6]. The DOA is the measure of the instantaneous level of activation of a behavior. The primitive behaviors are weighted by the DOA and aggregated to form composite behaviors. This is a general form of behavior fusion that can degenerate to behavior switching for DOA=0 or 1 [9].

At the Primitive level, behaviors are synthesized as fuzzy rule bases, i.e. collection of fuzzy if-then rules. Each behavior is encoded with a distinct control policy governed by fuzzy inference. If X and Y are input and output universes of discourse of a behavior with a rule-base of size n . the usual fuzzy if-then rule takes the following form:

$$IF\ x\ is\ A_i\ THEN\ y\ is\ B_i \tag{9}$$

where, x and y represent input and output fuzzy linguistic variables, respectively, and A_i and B_i ($i = 1...n$) are fuzzy subsets representing linguistic values of x and y . Typically, x refers to sensory data and y to actuator control signals. The antecedent and the consequent can also be a conjunction of propositions (e.g. IF x_1 is $A_{i,1}$ AND... x_n is $A_{i,n}$ THEN...).

At the composition level the DOA is evaluated using a fuzzy rule base in which global knowledge and constraints are incorporated. An activation level (threshold) at which rules become application is applied to the DOA giving the system more degrees of freedom. The DOA of each primitive behavior is specified in the consequent of applicability rules of the form:

$$IF\ x\ is\ A_i\ THEN\ \alpha_j\ is\ D_i \tag{10}$$

Where x is typically a global constraint, $\alpha_j \in [0,1]$ is the DOA and A_i and D_i , respectively are the fuzzy set of linguistic variable describing them. As in the former case the antecedent and consequent can also be a conjunction of propositions.

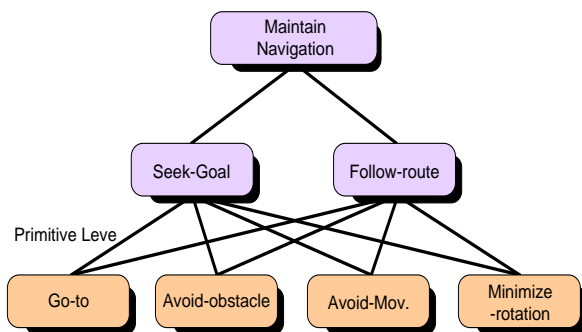

Fig. 3. Hierarchical behavior of mobile robot

A behavior hierarchy for indoor navigation might be organized as in Figure 3. It implies that goal-directed navigation can be decomposed as a behavioral function of **Seek-goal** and **Follow- route**. These behaviors can be further decomposed into the primitive behaviors shown, with dependencies indicated by the adjoining lines. **Avoid-obstacle** and **Minimize-rotation** are self-explanatory. The **go-to** behavior will direct a robot to navigate along a straight line trajectory to a goal position. The **Minimize-rotation** behavior implies one that can control a robot to rotate wheels smoothly by restraining the rapid motion [6,7].

4. EXPERIMENTS

After satisfactory simulation performance [10], the proposed navigation control system has been implemented and tested in a laboratory environment on a AmigoBot robot equipped with a CCD camera and Ultrasonic sensor ring (Fig. 4). This robot, which is manufactured by ActivMedia Robotics, is a differentially driven platform configured with two drive wheels and one swivel caster for balance. Each wheel is driven independently by a motor with 19.5:1 gear ratio which enables the robot to drive at a maximum speed of 1.2 m/s and climb a 25% grade. The proposed system was prepared using fuzzyTECH software, which generated C++ code that was implemented on the AmigoBot.

We use a DC motor for each wheel, and use a ball-caster for an assistant wheel. Two encoders, a gyro-sensor (ENV-05D), an ultrasonic sensor and a vision sensor are used for the navigation control. The gyro sensor is used for recognizing the orientation of robot by measuring the rotational velocity; the ultrasonic sensor (Polaroid 6500) is used for recognizing environment, which is rotated by a step motor within 180 degrees; the CCD camera (Sony EVI-D30) is used for detecting obstacles. A Pentium IV processor is used as a main controller and an 80C196KC microprocessor is used as a joint controller.



Fig. 4. Active camera system and AmigoBot mobile robot

Ultrasonic sensor is good in distance measurement of the obstacles, but it also suffers from specular reflection and insufficient directional resolution due to its wide beam-opening-angle.

So, we use a sensor fusion method to decide the distance and width of obstacles and avoid them during the navigation. ActivMedia examines whether measured value is data of distance to real obstacle or distance to its shadow. If difference of measured data by vision and ultrasonic sensor is within the error tolerance, ActivMedia uses measured data by vision sensor as distance to obstacle. Otherwise, ActivMedia uses measured data by vision sensor as distance to obstacle.

To control the wheels in real time, a distributed control system is implemented using a CAN based network. Three CAN-based controllers are connected to the network, among which a controller gathers the gyro sensor data and sends them to the wheel controllers. The CAN network was connected to a higher-level ISA bus which connects the 2 d.o.f pan/tilt camera controllers to a main controller. Every 100msec, the position of an object in 3D space was calculated using the posture of the camera and the object position on the image frame to plan the trajectory of the mobile robot. The planned trajectory commands were sent to the wheel controllers that uses PID algorithm to control the angle every 10 msec.

Fig. 5 depicts sensing coverage of vision and ultrasonic sensor used this experiment. Ultrasonic sensor can detect obstacles within 7m and Vision system can detect obstacles within the range of between 130cm and 870cm.

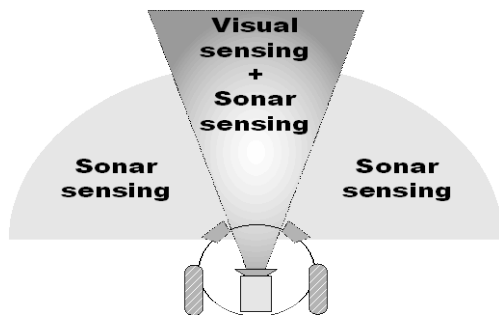

Fig. 5. Sensing coverage of vision and ultrasonic sensor

We experiment the recognition of obstacle using above equations and parameter values as shown in Fig. 6.

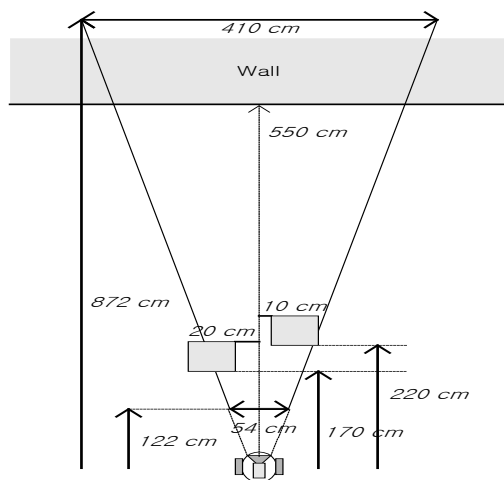
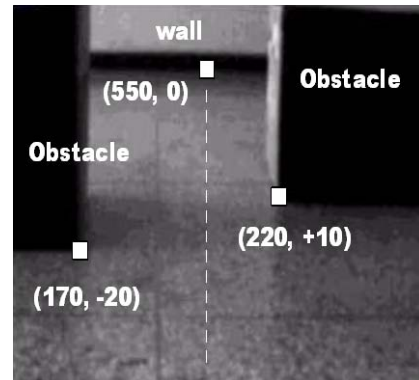
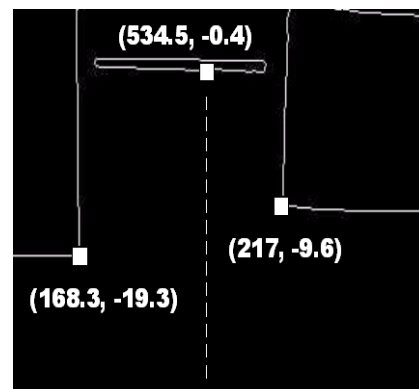

Fig. 6. Experimental environment in area A

Fig. 7(a) is the image used on the experiment; Fig. 7(b) is the values resulted from matching after image processing. Fig. 7. Shows that maximum matching error is within 4%. Therefore, It can be seen that above vision system is proper to apply to navigation. The mobile robot navigates along a corridor with 2m widths and with some obstacles as shown in Fig. 8(a). The real trace of the mobile robot is shown in Fig. 8(b). It demonstrates that the mobile robot avoids the obstacles intelligently and follows the corridor to the goal.



(a) Input image



(b) Result of matching

Fig. 7. Experimental result of the vision system in area A

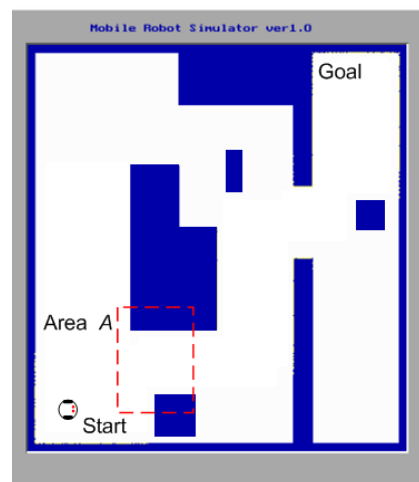

(a) Diagram of navigation in a corridor with obstacles

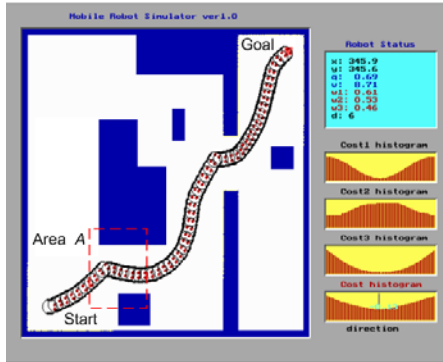

(b) Trajectory of the mobile robot in a corridor with obstacles
Fig. 8. Navigation of robot in corridor environment

5. CONCLUSIONS

A fuzzy control algorithm for both obstacle avoidance and path planning has been implemented in experiment so that it enables the mobile robot to reach to goal point under the unknown environments safely and autonomously.

And also, we showed an architecture for intelligent navigation of mobile robot which determine robot's behavior by arbitrating distributed control commands, seek goal, avoid obstacles, and maintain heading. Commands are arbitrated by endowing with weight value and combining them, and weight values are given by fuzzy inference method. Arbitrating command allows multiple goals and constraints to be considered simultaneously. To show the efficiency of proposed method, real experiments are performed.

To show the efficiency of proposed method, real experiments are performed. The experimental results show that the mobile robot can navigate to the goal point safely under unknown environments and also can avoid moving obstacles autonomously.

Our ongoing research endeavors include the validation of the more complex sets of behaviors, both in simulation and on an actual mobile robot. Further researches on the prediction algorithm of the obstacles and on the robustness of performance are required.

ACKNOWLEDGMENT

This paper was supported by the Basic Research Promotion Grant funded by the Dongseo University, and the Basic Science Research Program through the National Research Foundation of Korea(NRF) funded by the Ministry of Education, Science and Technology(No. 2010-0021054).

REFERENCES

- [1] L. A. Zadeh, "Outline of a New Approach to the Analysis of Complex Systems and Decision Processes," *IEEE*

Transactions on Systems, Man, and Cybernetics, vol.3, no.1, 28-44, January 1973.

- [2] D. Nair and J. K. Aggarwal, "Moving Obstacle Detection from a Navigation Robot," *IEEE Trans. on robotics and automation*, vol. 14, no. 3, pp. 404-416, June 1998.
- [3] S. Bentalba, A. ElHajjaji and A. Tachid, "Fuzzy Control of a Mobile Robot: a New Approach," *Proc. IEEE International Conference on Control Applications*, pp.69-72, October 1997.
- [4] H. R. Beom and H. S. Cho, "A sensor-Based Navigation for a Mobile Robot Using Fuzzy Logic and Reinforcement Learning," *IEEE Trans. on system, man, and cybernetics*, vol.25, no. 3, pp.464-477, March 1995.
- [5] A. Ohya, A. Kosaka and A. Kak, "Vision-Based Navigation by a Mobile Robot with Obstacle Avoidance Using Single-Camera Vision and Ultrasonic Sensing," *IEEE Transactions on Robotics and Automation*, vol. 14, no. 6, pp. 969-978, December 1998.
- [6] E. Tunstel, "Fuzzy behavior modulation with threshold activation for autonomous vehicle navigation," *Proc. of the 18th Int Conf of the North American Fuzzy Information Processing Society*, New York, pp. 776-780, 1999.
- [7] E. Tunstel, "Fuzzy-behavior synthesis, coordination, and evolution in an adaptive behavior hierarchy," *Fuzzy Logic Techniques for Autonomous 470 TUNSTEL, de OLIVEIRA, AND BERMAN Vehicle Navigation, Studies in Fuzziness and Soft Computing*(A. Saffiotti, D. Driankov, Eds.), chapter 9, Springer-Verlag, 2000.
- [8] Mehrjerdi, H.; Saad, M.; Ghommam, J., "Hierarchical Fuzzy Cooperative Control and Path Following for a Team of Mobile Robots," *IEEE/ASME Transactions on Mechatronics*, vol. 16, no. 5, pp. 907-917, 2011.
- [9] Wang Dongshu; Zhang Yusheng; Si Wenjie, "Behavior-based hierarchical fuzzy control for mobile robot navigation in dynamic environment," *Proc. of 2011 Chinese Control and Decision Conference(CCDC)*, pp. 2419- 2424, 2011.
- [10] T. S. Jin, H. S. Kim and J. W. Kim, "Landmark Detection based on Sensor Fusion for Mobile Robot Navigation in a Varying Environment," *International Journal of Fuzzy Logic and Intelligent Systems*, vol. 10, no.4, pp. 281-286, 2010.



Tae-Seok Jin

He received the Ph.D. degree from Pusan National University, Busan, Korea, in 2003, in electronics engineering.

He is currently an Assistant Professor at DongSeo University. From 2004 to 2005, he was a Postdoctoral Researcher at the Institute of Industrial Science, The University of

Tokyo, Japan. His research interests include network sensors fusion, mobile robots, computer vision, and intelligent control. Dr. Jin is a Member of the KIIS, ICROS, and RSJ.