

On the Polynomial of the Dunwoody $(1, 1)$ -knots

SOO HWAN KIM AND YANGKOK KIM*

Department of Mathematics, Dongeui University, Pusan 614-714, Korea
e-mail: sootopology@hanmail.net and ykkim@deu.ac.kr

ABSTRACT. There is a special connection between the Alexander polynomial of $(1, 1)$ -knot and the certain polynomial associated to the Dunwoody 3-manifold ([3], [10] and [13]). We study the polynomial (called the Dunwoody polynomial) for the $(1, 1)$ -knot obtained by the certain cyclically presented group of the Dunwoody 3-manifold. We prove that the Dunwoody polynomial of $(1, 1)$ -knot in \mathbb{S}^3 is to be the Alexander polynomial under the certain condition. Then we find an invariant for the certain class of torus knots and all 2-bridge knots by means of the Dunwoody polynomial.

1. Introduction

We begin with the fact that every closed 3-manifold has a spine called the Heegaard diagram, from which one can obtain the presentation for the group; however, not all group presentations arise from the spines of 3-manifolds. Therefore, determining which cyclic presentations of groups correspond to spines of closed 3-manifolds is an open problem.

In 1968, L. Neuwirth introduced an algorithm for the construction of a connected closed orientable 3-manifold from 2-complex, which corresponds to a group presentation ([17]). In 1994, M. J. Dunwoody introduced the 6-tuples yielding a family of genus n Heegaard diagrams of closed orientable 3-manifolds called the Dunwoody 3-manifold ([10]). In 2000, author in [19] first proposed that the branched set in the quotient space of the Dunwoody 3-manifold is a $(1, 1)$ -knot in \mathbb{S}^3 . In other words, at least one cyclic symmetry on the Dunwoody 3-manifold induces a $(1, 1)$ -knot. In 2004, it was shown that some classes of knots represented by the Dunwoody 3-manifolds contain all $(1, 1)$ -knots in \mathbb{S}^3 ([5]).

Conversely, for a given $(1, 1)$ -knot K , it is an interesting problem to determine a type of the Dunwoody 3-manifold representing K even if it is not unique. Until

* Corresponding Author.

Received May 8, 2010; accepted February 19, 2012.

2010 Mathematics Subject Classification: Primary 57M12, 57M25, 57M27, 57M50; Secondary 57M05, 57M10, 57M15, 57M60.

Key words and phrases: Torus knot, $(1, 1)$ -knot, $(1, 1)$ -decomposition, Dunwoody 3-manifold, Alexander polynomial, Heegaard splitting, Heegaard diagram.

This work was supported by Dong-eui University Grant(2010AA088).

now these problems for all 2-bridge knots and some torus knots were solved in [11], [14] and [19]. For example, the explicit type for the torus knot $T(p, q)$ satisfying $q \equiv \pm 1 \pmod p$ has been obtained in [1] and [5], and for the torus knot $T(p, q)$ satisfying $q \equiv \pm 2 \pmod p$, the type has been obtained in [13]. Furthermore, in [6], it has been obtained for all torus knots with bridge number at most three. However to determining types of Dunwoody 3-manifolds for all torus knots is still unknown.

The Dunwoody 3-manifold plays an important role in determining which cyclically presented group corresponds to a 3-manifold. Indeed, in order to study a 3-manifold with some particular group as the fundamental group, the Dunwoody 3-manifold has a Heegaard diagram from which one can obtain a presentation for the group. Thus, to find the Dunwoody 3-manifold, one must seek a cyclically presented group associated with a 3-manifold. Furthermore, as in [12], the branched covering space of the spatial Θ -curve containing $(1, 1)$ -knots as the constituent knots is related to the Dunwoody 3-manifold. Therefore the concept of the Dunwoody 3-manifold is important in knot, branched covering and graph theories.

In section 2, we introduce a set of 4-tuples representing all $(1, 1)$ -knots, which is determined by two permutations, and so 3-manifolds related to a set of 4-tuples are containing the Dunwoody 3-manifolds. In particular, we prove that the strongly-cyclic branched covering space of the Dunwoody $(1, 1)$ -knot represented by the certain 4-tuples is homeomorphic to the Dunwoody 3-manifold. Moreover we show some conditions of the Dunwoody $(1, 1)$ -knot representing a torus knot; and we also discuss about the type of the Dunwoody 3-manifold representing the torus knot.

In Section 3, we show that the fundamental group of the Dunwoody 3-manifold admits a cyclic presentation, which is independent of results in [4] and [16]; and we define the Dunwoody polynomial from the cyclic presentation. As the main result, we show that the Dunwoody polynomial for the Dunwoody $(1, 1)$ -knot in \mathbb{S}^3 is the Alexander polynomial under some condition. For the results in [3] and [4], they are shown the connection between the Dunwoody polynomial and the projection of Alexander polynomial into $\mathbb{Z}[t]/(t^n - 1)$ for some $n > 1$. Moreover we show that a certain numerical number from the Dunwoody polynomial is an invariant for some torus knots and all 2-bridge knots of $(1, 1)$ -knots. This result gives an answer to a question in [10]. In this note, all lens spaces will be assumed to include \mathbb{S}^3 but not $\mathbb{S}^1 \times \mathbb{S}^2$. The basic facts about lens spaces are covered in [18].

2. On the Dunwoody $(1, 1)$ -knots

Let (V_1, V_2) be a Heegaard splitting with genus n of a closed orientable 3-manifold M . A properly embedded disc D in the handlebody V_2 is called a meridian disc of V_2 if cutting V_2 along D yields a handlebody of genus $n - 1$. A collection of n mutually disjoint meridian discs $\{D_i\}$ of V_2 is called a complete system of meridian discs of V_2 if cutting V_2 along $\cup_i D_i$ gives a 3-ball. Let c_i denote the 1-sphere ∂D_i which lies in the closed orientable surface $\partial V_1 = \partial V_2$ of genus n . Then the system is

said to be a Heegaard diagram of M denoted by $(V_1; c_1, c_2, \dots, c_n)$. Let M be a lens space and K be a knot in M . Then the pair (M, K) admits a $(1, 1)$ -decomposition if there exists a Heegaard splitting of genus one $(V_1, K_1) \cup_\phi (V_2, K_2)$ of (M, K) such that $(V_1; c_1)$ is a Heegaard diagram of M , and $K_1 \subset V_1$ and $K_2 \subset V_2$ are properly embedded trivial arcs, where ϕ is an attaching homeomorphism.

We now introduce the Dunwoody $(1, 1)$ -decomposition of (M, K) determined by two permutations and 4-tuples (a, b, c, r) , where $a > 0, b \geq 0, c \geq 0, r \in \mathbb{Z}_d$, and $d = 2a + b + c$. Let m^+ and m^- be two circles with each other different orientations, and let $X^+ = \{1, 2, \dots, d\}$ and $X^- = \{-1, -2, \dots, -d\}$ be sets of d vertices in m^+ and m^- , respectively. We now define two permutations α and β as below, where all numbers are under $\text{mod } d$.

$$\alpha(j) = \begin{cases} d - j + 1 & \text{if } 1 \leq j \leq a \\ -j - c & \text{if } a + 1 \leq j \leq a + b \\ -j + b & \text{if } a + b + 1 \leq j \leq a + b + c \\ -d - j - 1 & \text{if } -a \leq j \leq -1 \end{cases}$$

and

$$\beta(j) = \begin{cases} -j + r & \text{if } r < j \\ -j + r - d & \text{otherwise} \end{cases} .$$

The cycle expressions of α and β are the following.

$$\begin{aligned} \alpha &= (1, d)(2, d - 1)(3, d - 2) \cdots (a, d - a + 1) \\ & (a + 1, -(a + c + 1)) \cdots (a + b, -(a + c + b)) \\ & (a + b + 1, -(a + 1)) \cdots (a + b + c, -(a + c)) \\ & (-1, -d)(-2, -(d - 1)) \cdots (-a, -(d - a + 1)) (*) \end{aligned}$$

and

$$\begin{aligned} \beta &= (1, -(1 - r))(2, -(2 - r)) \cdots (j, -(j - r)) \\ & \cdots (d, -(d - r)). (**) \end{aligned}$$

We note that each 2-cycle in α consists of the end points of a curve connecting m^+ and m^- or themselves as the rule of Figure 1; and each 2-cycles in β generates a meridian disk m , by gluing the corresponding points in m^+ and m^- via β . For example, $(r, -(r - r))$ means that the number r of m^+ is identified with the number $-(r - r) = -0 = -d$ in m^- . Thus $\beta\alpha$ determines the genus one solid torus V_1 and the disjoint simple closed curves on ∂V_1 .

Theorem 2.1. *If L is the number of the disjoint simple closed curves on ∂V_1 , then there are two permutations α and β such that $|\alpha| - |\beta| + 2L = |\beta\alpha|$, where $|\cdot|$ means the number of disjoint cycles in a permutation.*

Proof. Let $d = 2a + b + c$. Let $X^+ = \{1, 2, \dots, d\}$ and $X^- = \{-d, -d + 1, \dots, -1\}$ be sets of d points in m^+ and m^- , respectively. Then the permutation α is consisting of

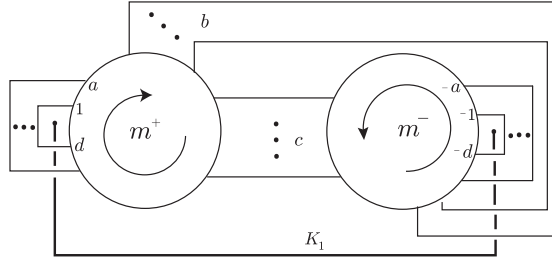

Figure 1: The Dunwoody $(1, 1)$ -decomposition $D(a, b, c, r)$

d 2-cycles by two end points of line segments connecting m^+ and m^- or themselves on ∂V_1 , and the permutation β is consisting of d 2-cycles connecting m^+ and m^- on ∂V_1 . We now define an equivalence relation on $X = X^+ \cup X^-$ by

$$x \sim y \text{ if } y = (\beta\alpha)^i(x) \text{ or } y = \alpha(\beta\alpha)^i(x) \text{ for some } i.$$

Then we call the equivalence classes of X under the relation the orbits of $\beta\alpha$. Let l be a simple closed curve on ∂V_1 and x be a point on m^+ meeting l . Then l is determined by the repeated applications of α and β as follows;

$$x, \alpha(x), \beta\alpha(x), \alpha\beta\alpha(x), \dots, \alpha\beta \cdots \alpha(x),$$

which forms an orbit of $\beta\alpha$. Each orbit of $\beta\alpha$ determines a simple closed curve in ∂V_1 . Let Y_1, \dots, Y_L be orbits of $\beta\alpha$. If $x \in Y_i$ and d is the smallest positive integer such that $(\alpha\beta)^d(x) = x$, then on Y_i , $\beta\alpha$ is expressed as a product $\beta_i\alpha_i$ of two disjoint permutations α_i and β_i of the same length:

$$\alpha_i = (x, \beta\alpha(x), (\beta\alpha)^2(x), \dots, (\beta\alpha)^{d-1}(x))$$

and

$$\beta_i = (\alpha(x), \alpha\beta\alpha(x), \dots, (\alpha\beta)^{d-1}\alpha(x)).$$

Furthermore the $\beta_i\alpha_i$ are pairwise disjoint and

$$\beta\alpha = (\beta_L\alpha_L) \cdots (\beta_2\alpha_2)(\beta_1\alpha_1).$$

Moreover

$$|\beta\alpha| = |\beta_L\alpha_L| + \cdots + |\beta_1\alpha_1| = 2L. \quad \square$$

Since two consecutive cycles in $\beta\alpha$ determine a simple closed curve (which is isotopic to $c_1 = \partial D_1$) on ∂V_1 , we assume that l is the simple closed curve determined by α and β on ∂V_1 whenever $L = 1$. Let K_1 be a trivial arc in V_1 such that $K_1 \cap \partial V_1 = \partial K_1$, which is situated inside the bigons bounded by 2-cycles $(1, d)$ and $(-1, -d)$ as shown in Figure 1. Then a set of 4-tuples of integers

$$\mathcal{D} = \{(a, b, c, r) | a > 0, b \geq 0, c \geq 0,$$

$$d = 2a + b + c, r \in \mathbb{Z}_d, |\alpha\beta| = 2\}$$

admits a (1, 1)-decomposition of (M, K) called *the Dunwoody (1, 1)-decomposition*. For each (a, b, c, r) in \mathcal{D} , we denote the Dunwoody (1, 1)-decomposition of (M, K) by $D(a, b, c, r)$. (See Figure 1.) Moreover, we denote a (1, 1)-knot K represented by $D(a, b, c, r)$ by $K(a, b, c, r)$, and call it *the Dunwoody (1, 1)-knot*. We note that every (1, 1)-knot can be represented by the Dunwoody (1, 1)-knot and vice versa([5]). The representation of a (1, 1)-knot by Dunwoody (1, 1)-decomposition is not unique. For example, both $K(1, 3, 4, 7)$ and $K(2, 1, 4, 4)$ represent the pretzel knot $P(-2, 3, 7)$ which is a (1, 1)-knot as was mentioned in [19]. The subset of \mathcal{D} representing all 2-bridge knots was determined by [11], [14] and [19]. However, the subset of \mathcal{D} representing all torus knots is not yet determined completely. In [1], [5], [13] and [6] we have Dunwoody (1, 1)-decompositions representing the certain class of torus knots.

We now construct a family of 3-manifolds which are the n -fold strongly-cyclic coverings branched over Dunwoody (1, 1)-knots. Let M be a lens space and K be a Dunwoody (1, 1)-knot in M . Then the n -fold cyclic covering of M branched over K is completely defined by an epimorphism $C : H_1(M - K) \rightarrow \mathbb{Z}_n$, where \mathbb{Z}_n is the cyclic group of order n . Let r_1 be a generator of ∂V_1 , which is the boundary of the meridian disk meeting with K_1 at one point and let r_2 be a generator of ∂V_1 , which is the longitude curve meeting with r_1 at one point. Then every curve of ∂V_1 determined by two permutations α and β is generated by r_1 and r_2 . In other words, the orbit l of $\beta\alpha$ is generated by r_1 and r_2 . We define $l_i(1 \leq i \leq 6)$ from the oriented curve l on $D(a, b, c, r)$ as follows.

- l_1 is the number of left directed arrows from m^+ or m^- to m^+ or m^- in a edges respectively.
- l_2 is the number of right directed arrows from m^+ or m^- to m^+ or m^- in a edges respectively.
- l_3 is the number of arrows directed from m^+ to m^- in b edges.
- l_4 is the number of arrows directed from m^- to m^+ in b edges.
- l_5 is the number of arrows directed from m^+ to m^- in c edges.
- l_6 is the number of arrows directed from m^- to m^+ in c edges.

From now on for $D(a, b, c, r)$ we let $p = (l_3 + l_5) - (l_4 + l_6)$, $q = (l_1 + l_3) - (l_2 + l_4)$ and $d = 2a + b + c$. If $p = \pm 1$ or $p = 0$, then M is \mathbb{S}^3 or $\mathbb{S}^1 \times \mathbb{S}^2$ ([11] and [12]), respectively. Thus $p \neq 0$ if M is not $\mathbb{S}^1 \times \mathbb{S}^2$. We have $\pi(M) = \langle x | x^{\pm p} \rangle = \mathbb{Z}_{|p|}$ and $H_1(M - K) = \langle r_1, r_2 | pr_2 + qr_1 \rangle = \mathbb{Z} \oplus \mathbb{Z}_{gcd(p,q)}$. By definition, the n -fold cyclic covering f of M branched over K is called strongly-cyclic if the branching index of K is n . That is, the fiber $f^{-1}(x)$ of each point $x \in K$ contains a single point. Therefore the homology class of a meridean loop r_1 around K is mapped by C in a generator of \mathbb{Z}_n , say $C(r_1) = 1$, and so there exists an n -fold strongly-cyclic

covering space \overline{M} of M branched over K if and only if there is $s = C(r_2) \in \mathbb{Z}_n$ such that $ps + q \equiv 0 \pmod n$. We call the diagram in Figure 2 a Heegaard diagram of \overline{M} and denote it by $D_n(a, b, c, r, s)$. If the Dunwoody $(1, 1)$ -knot K is in \mathbb{S}^3 , the

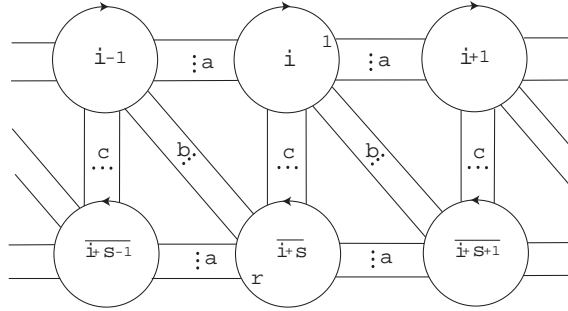

Figure 2: A Heegaard diagram $D_n(a, b, c, r, s)$

strongly-cyclic branched covering is the same that cyclic branched covering. Indeed the n -fold cyclic branched covering of K in \mathbb{S}^3 always exists and is unique up to equivalence for $n > 1$ because $H_1(\mathbb{S}^3 - K) = \mathbb{Z}$, the homology class r_1 is mapped by C in a generator of \mathbb{Z}_n and $s = C(r_2) = -q$.

We have proved the following.

Theorem 2.2. *Let $D(a, b, c, r)$ be the Dunwoody $(1, 1)$ -decomposition of (M, K) and $n > 1$. Then \overline{M} is homeomorphic to a 3-manifold if and only if there is an integer s such that $ps + q \equiv 0 \pmod n$.*

We notice that $D_n(a, b, c, r, s)$ satisfies the conditions for the Heegaard diagram of the Dunwoody 3-manifold considered in [10]. Thus we have the following.

Corollary 2.3. *Let M be a lens space and K be a Dunwoody $(1, 1)$ -knot in M . Then the n -fold strongly-cyclic covering space \overline{M} of M branched over K is homeomorphic to the Dunwoody 3-manifold.*

Corollary 2.4. [12] *$D(a, b, c, r)$ is the $(1, 1)$ -decomposition of (\mathbb{S}^3, K) if and only if $|p| = 1$.*

From the result of Corollary , if $d = 2a + b + c$ is even, then $D(a, b, c, r)$ cannot be a $(1, 1)$ -decomposition of (\mathbb{S}^3, K) because d has the same parity of p . (See [15] for detail.)

Generally, for the following set

$$\mathcal{S} = \{(a, b, c, r) | a > 0, b \geq 0, c \geq 0,$$

$$d = 2a + b + c, r \in \mathbb{Z}_d, |\alpha\beta| = 2L\},$$

we suppose that $L \geq 2$ is the number of simple closed curves determined by α and β on ∂V_1 . Given an $(a, b, c, r) \in \mathcal{S}$, it is possible to represent a link in lens spaces containing \mathbb{S}^3 and $\mathbb{S}^1 \times \mathbb{S}^2$. Thus the orientable 3-manifold \bar{M} in existing is a generalization of the Dunwoody 3-manifold introduced in [10], called *the generalized Dunwoody 3-manifold*. (See [15],[13] or [7] for some examples.)

We let $L = 1$. That is, for each $(a, b, c, r) \in \mathcal{D}$, $K(a, b, c, r)$ is the Dunwoody (1, 1)-knot in a lens space or \mathbb{S}^3 . We now consider the Dunwoody (1, 1)-knot representing the torus knot. The torus knot is a knot embedded in the standard torus T in \mathbb{S}^3 . Regarding T as the boundary of tubular neighborhood of trivial knot in \mathbb{S}^3 , we take a meridian-longitude system (m_1, m_2) of trivial knot on T . The torus knot is said to be of type (k_1, k_2) , denoted by $T(k_1, k_2)$, if it is homologous to $k_1 m_1 + k_2 m_2$ in T for some coprime integers k_1 and k_2 .

The Dunwoody (1, 1)-knots representing $T(k_1, k_2)$ with $k_2 \equiv \pm 1 \pmod{k_1}$ have been obtained in [1] and [5]. Moreover, the Dunwoody (1, 1)-knots representing the torus knots with bridge number at most three have been obtained in [6]. Furthermore the Dunwoody (1, 1)-knots representing $T(k_1, k_2)$ with $k_2 \equiv \pm 2 \pmod{k_1}$ have been obtained in [13] with explicit formulae: (i) $T(k_1, k_2)$ with $k_2 \equiv 2 \pmod{k_1}$ is represented by $K(a, b, c, r)$, where

$$(2.1) \quad \begin{cases} a = \frac{k_1-1}{2} \\ b = 1 \\ c = \frac{(k_1+1)(k_1-1)(k_2-2)}{2k_1} \\ r = \frac{-k_1+(k_1)^2 k_2-k_2+2-(k_1)^3}{2k_1} \end{cases},$$

and (ii) $T(k_1, k_2)$ with $k_2 \equiv -2 \pmod{k_1}$ is represented by $K(a, b, c, r)$ where

$$(2.2) \quad \begin{cases} a = \frac{k_1-1}{2} \\ b = 1 \\ c = \frac{(k_1)^2 k_2-2(k_1)^2-k_2-2}{2k_1} \\ r = \frac{1}{2}(k_1)^2 - \frac{3}{2} \end{cases}.$$

In the following theorem the conditions for $K(a, b, c, r)$ to represent a torus knot will be given where $|X_1 \cap X_2|$ means the number of intersecting points between two sets X_1 and X_2 .

Theorem 2.5. *Let $D(a, b, c, r)$ be the Dunwoody (1, 1)-decomposition of (\mathbb{S}^3, K) . Suppose that m is the meridian disk determined by β and l is the simple closed curve defined by $\beta\alpha$ such that $|K_1 \cap K_2| = 2$, $|K_1 \cap l| = k_1$, and $|K_2 \cap m| = k_2$, for some coprime integers k_1 and k_2 . Then $K(a, b, c, r)$ is $T(k_1, k_2)$, where $k_1 = 2a + b$ and $k_2 \leq c + 2$.*

Proof. There exists a Heegaard splitting of genus one $(V_1, K_1) \cup_\phi (V_2, K_2)$ of (\mathbb{S}^3, K) ,

where V_1 and V_2 are solid tori, $K_1 \subset V_1$ and $K_2 \subset V_2$ are properly embedded trivial arcs, and $\phi : (\partial V_2, \partial K_2) \rightarrow (\partial V_1, \partial K_1)$ is an attaching homeomorphism. Since $|K_1 \cap K_2| = 2$, K_1 and K_2 do not meet each other except the bigons determined by the 2-cycles $(1, d)$ and $(-1, -d)$. Thus the meridian-longitude system (m, l) satisfies $|K_1 \cap l| = 2a + b$ and $|K_2 \cap m| \leq c + 2$. Let $k_1 = 2a + b$ and $k_2 = |K_2 \cap m|$ be integers satisfying $\gcd(k_1, k_2) = 1$. Then $K = K_1 \cup_\phi K_2$ is homologous to $k_1 m + k_2 l$ in V_1 . Therefore $K(a, b, c, r)$ is $T(k_1, k_2)$. \square

The inequality $k_2 \leq c + 2$ in Theorem 2.5 is the generalization of Theorem 4.2(iii) in [8]. That is, $K(1, 0, 2k - 1, 2)$ is equivalent to $T(2k + 1, 2)$. We also note that the Dunwoody $(1, 1)$ -decomposition $D(a, b, c, r)$ representing $T(k_1, k_2)$ with $k_2 \equiv \pm 2 \pmod{k_1}$ satisfies the conditions in Theorem 2.5.

Example 1. Let $D(1, 2, 3, 3)$ be a $(1, 1)$ -decomposition of $(\mathbb{S}^3, K) = (V_1, K_1) \cup_\phi (V_2, K_2)$ and $|(l_3 + l_5) - (l_4 + l_6)| = 1$. (See Figure 3.) Then $|K_1 \cap l| = 4$, $|K_2 \cap m| = 5$, and $|K_1 \cap K_2| = 2$, which are marked by circled numbers, numbers and dots respectively in Figure 3. Thus $D(1, 2, 3, 3)$ satisfies the conditions of Theorem 2.5 and so $K(1, 2, 3, 3)$ is $T(4, 5)$.

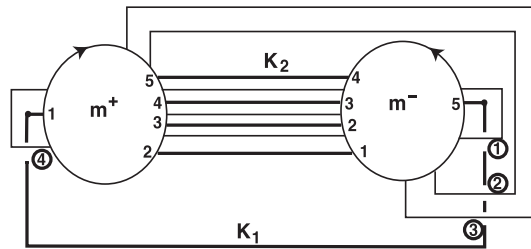

Figure 3: A $(1, 1)$ -decomposition $D(1, 2, 3, 3)$ of $T(4, 5)$

3. The Alexander polynomial vs the Dunwoody polynomial

In this section, we show that (i) the certain polynomial of the Dunwoody $(1, 1)$ -knot in \mathbb{S}^3 is the Alexander polynomial, and that (ii) if $K(a, b, c, r)$ is the Dunwoody $(1, 1)$ -knot representing 2-bridge knot or some torus knots, then the number $d = 2a + b + c$ is an invariant for $K(a, b, c, r)$. For the Dunwoody polynomial, (i) gives an answer to a question in [10].

Theorem 3.1. *The n -fold strongly-cyclic branched covering of the Dunwoody $(1, 1)$ -knot in a lens space admits a cyclically presented fundamental group.*

Proof. When we consider the Dunwoody $(1, 1)$ -knot $K(a, b, c, r)$ in a lens space, $\beta\alpha$ has two cycles of length d such that $(\beta\alpha)^d(x) = x$ for each x on $D(a, b, c, r)$ by Theorem 2.1. Thus the n -fold strongly-cyclic branched covering of $K(a, b, c, r)$ is homeomorphic to the Dunwoody 3-manifold $D_n(a, b, c, r, s)$. Since $ps + q \equiv 0 \pmod{n}$,

the path corresponding to this cycle connects the endpoint labelled 1 in the hole labelled 0 to the endpoint labelled 1 in the hole labelled $\overline{ps + q}$ under $\text{mod } n$. That is, the condition $ps + q \equiv 0 \pmod n$ ensures that the path corresponding to the cycles is a simple closed curve with an orientation. Since $D_n(a, b, c, r, s)$ has n simple closed curves, each path starting at the endpoint labelled 1 in the hole labelled i corresponding to the cycles of $\beta\alpha$ will be connected to the endpoint labelled 1 in the hole labelled \bar{i} under $\text{mod } n$. With notations in [13], $w(C_i)$ (resp. $w(\bar{C}_i)$) is a cyclic presentation obtained by reading off simple closed curves around the hole labelled i (resp. \bar{i}). Thus the identification of C_i and \bar{C}_i by r on $D_n(a, b, c, r, s)$ induces $w(C_i) \approx_r w(\bar{C}_i)$. If $i = 0$, then

$$u\eta^s(c)\eta^{s-1}(b)\eta^{-1}(u^{-1}) \approx_r abc\eta^{-1}(a^{-1}),$$

from which we have a cyclic presentation for the fundamental group. □

For the specific example, let the Dunwoody (1, 1)-knot $K(a, b, c, r)$ represent $T(p, q)$ such that p is odd and $q \equiv \pm 2 \pmod p$. Then the n -fold cyclic covering of S^3 branched over $K(a, b, c, r)$ satisfies $u\eta^s(c)\eta^{s-1}(b)\eta^{-1}(u^{-1}) \approx_r abc\eta^{-1}(a^{-1})$ (for reference see [13]), where the parameter s is equal to $-s$ in [13].

From [3], [9] and [20], we recall the definition of the Alexander polynomial of a knot in compact connected 3-manifold. We also note that every finitely generated abelian group G is a direct sum of a torsion-free part $F(G)$ and a torsion-part $T(G)$. For the group G , we denote its integral group ring by $\mathbb{Z}[G]$. In particular, the first homology group $H_1(N)$ of a compact connected 3-manifold N has a decomposition

$$H_1(N) \cong F(H_1(N)) \oplus T(H_1(N)).$$

The projection $J : H_1(N) \rightarrow H_1(N)/T(H_1(N))$ induces the ring homomorphism $J' : \mathbb{Z}[H_1(N)] \rightarrow \mathbb{Z}[H_1(N)/T(H_1(N))]$. If k is the first Betti number of N and t_1, \dots, t_k are generators of $H_1(N)/T(H_1(N))$, then we have

$$\mathbb{Z}[H_1(N)/T(H_1(N))] \cong \mathbb{Z}[t_1, t_1^{-1}, \dots, t_k, t_k^{-1}].$$

Let $h : \pi_1(N, *) \rightarrow H_1(N)$ be the Hurewitz homomorphism, where $*$ is a fixed point in N . Denote $E_1(N) \subset \mathbb{Z}[H_1(N)]$ and $E'_1(N)$ with the first elementary ideal of $\pi_1(N, *)$ and the smallest principal ideal of $\mathbb{Z}[H_1(N)/T(H_1(N))]$ containing $J'(E_1(N))$, respectively. The generator Δ_N of $E'_1(N)$ is well-defined up to multiplication by units of $\mathbb{Z}[t_1, t_1^{-1}, \dots, t_k, t_k^{-1}]$ and is said to be the Alexander polynomial of N . Let K be a knot in a compact connected 3-manifold M . Then the Alexander polynomial Δ_N of $N = M - K$ is the Alexander polynomial of K and it will be denoted by Δ_K instead of Δ_N for a knot K .

Let R be a unital commutative ring and let

$$G_n \cong \langle x_0, x_1, \dots, x_{n-1} | r_0, \dots, r_{n-1} \rangle$$

be a finitely-presented R -module, where each relation r_i is a linear combination of the generators x_j : $r_i = a_{i0}x_0 + \cdots + a_{i(n-1)}x_{n-1}$. In other words, G_n is generated as an R module by the elements x_0, \cdots, x_{n-1} , and $r_0 = 0, \cdots, r_{n-1} = 0$ are relations among the x_i 's. Then we can define a presentation matrix to be an $n \times n$ matrix with entries a_{ij} for $0 \leq i \leq n-1, 0 \leq j \leq n-1$. An Alexander matrix is a presentation matrix for $H_1(\tilde{X})$ as a $\mathbb{Z}[t, t^{-1}]$ module, where \tilde{X} is the infinite cyclic cover of the knot complement N . The ideal generated by the Alexander matrix is the Alexander ideal of the knot, so the Alexander ideal is principal ([18], P.207). Any generator of this principal ideal is the Alexander polynomial Δ_K for a knot K . In fact, it was discovered by Alexander [2] in the 1920s, early in the history of topology, using the homology of the infinite cyclic cover of a knot complement.

In this section, let M be a lens space and denoted by $L(p, q')$, where p and q' are relatively prime. Considering the Dunwoody $(1, 1)$ -knot K in M , we have $F(H_1(N)) \cong \mathbb{Z}$ and $T(H_1(N)) \cong \mathbb{Z}_{gcd(p, q)}$. Thus $\Delta_K(t) \in \mathbb{Z}[t, t^{-1}]$ is the Alexander polynomial of K . In particular, for K in \mathbb{S}^3 , $\Delta_K(t) \in \mathbb{Z}[t, t^{-1}]$ has the properties (i) $\Delta_K(t) = \Delta_K(t^{-1})$ and (ii) $\Delta_K(1) = \pm 1$. Vice versa, every polynomial in $\mathbb{Z}[t, t^{-1}]$ satisfying (i) and (ii) is the Alexander polynomial of a knot in \mathbb{S}^3 ([9]). However, by Theorem B in [20], for the Alexander polynomial of K in M , it is true for the condition (i), but the condition (ii) is no longer true. See also [21].

Now we introduce the Dunwoody polynomial of the Dunwoody $(1, 1)$ -knot $K = K(a, b, c, r)$, and study the connections between the Dunwoody polynomial and the Alexander polynomial for K . Let $n > 1$. Then the n -fold strongly-cyclic branched covering $D_n(a, b, c, r, s)$ of K in M admits a cyclically presented fundamental group by Corollary 2.3 and Theorem 3.1. Due to the cyclic symmetry of $D_n(a, b, c, r, s)$, the fundamental group has the cyclic presentation induced by a single word $w(x_0, x_1, \cdots, x_{n-1})$ as following:

$$G_n(w(x_0, x_1, \cdots, x_{n-1})) = \langle x_0, x_1, \cdots, x_{n-1} | \\ \theta^j(w(x_0, x_1, \cdots, x_{n-1})), 0 \leq j \leq n-1 \rangle$$

where θ is the automorphism on the free group $F_n = \langle x_0, \cdots, x_{n-1} \rangle$ of rank n defined by $\theta(x_i) = x_{i+1}$ and all indices are taken under mod n . Since θ is an automorphism of order n , the relations

$$\{\theta^j(w(x_0, x_1, \cdots, x_{n-1})) | 0 \leq j \leq n-1\}$$

are independent of j with $0 \leq j \leq n-1$, that is, for any $0 \leq j \leq n-1$,

$$G_n(w(x_0, x_1, \cdots, x_{n-1})) \cong \\ G_n(\theta^j(w(x_0, x_1, \cdots, x_{n-1}))).$$

The relations $\theta^j(w(x_0, x_1, \cdots, x_{n-1})), 0 \leq j \leq n-1$, are determined by n disjoint simple closed curves on $D_n(a, b, c, r, s)$. For a relation $w(x_0, x_1, \cdots, x_{n-1}) \in$

$\{\theta^j(w(x_0, x_1, \dots, x_{n-1})) \mid 0 \leq j \leq n-1\}$, the relation $w(x_0, x_1, \dots, x_{n-1})$ is said to be *principal* if all indices in $w(x_0, x_1, \dots, x_{n-1})$ are independent of n . For the cyclic presentation $G_n(w(x_0, x_1, \dots, x_{n-1}))$ by $w(x_0, x_1, \dots, x_{n-1})$, we obtain the abelianized word $\sum_{i=0}^k a_i \bar{x}_i$, ($a_i \in \mathbb{Z}$), of w and a polynomial $f_w^n(t) = \sum_{i=0}^k a_i t^i \in \mathbb{Z}[t, t^{-1}]$ obtained by substituting t^i into \bar{x}_i is called *the Dunwoody polynomial* determined by $D_n(a, b, c, r, s)$. Moreover, by the multiplications of $\pm t^j$ ($j \in \mathbb{Z}$), we can normalize $f_w^n(t) \in \mathbb{Z}[t, t^{-1}]$ in order to have the polynomial with a positive constant term and positive exponents in $\mathbb{Z}[t]$. Let $f_w^n(t) \in \mathbb{Z}[t]$ and $n > 1$. Then $f_{\theta^j(w)}^n(t)$ ($0 \leq j \leq n-1$) are different polynomials in $\mathbb{Z}[t]$, but they are the same in the quotient ring $\mathbb{Z}[t]/(t^n - 1)$, up to units. From now on, we will consider the Dunwoody polynomial $f_{w_k}^n(t)$ as an element of $\mathbb{Z}[t]/(t^n - 1)$. For some n , we say that $D_n(a, b, c, r, s)$ admits the principal cyclic presentation $G_n(w)$ if w is principal.

Example 2. For $n > 4$, $\pi(D_n(3, 1, 2, 2, -1))$ has a cyclic presentation induced by

$$w(x_0, x_1, x_2, x_3, x_4) = x_1 x_2 x_3 x_4^{-1} x_3 x_2^{-1} x_2^{-1} x_1 x_0^{-1}.$$

Thus $\pi(D_n(3, 1, 2, 2, -1))$ is presented by

$$\langle x_0, x_1, \dots, x_{n-1} \mid \theta^j(x_1 x_2 x_3 x_4^{-1} x_3 x_2^{-1} x_2^{-1} x_1 x_0^{-1}), \\ 0 \leq j \leq n-1 \rangle.$$

Thus $f_w^n(t) = 1 - 2t + t^2 - 2t^3 + t^4$ is the Dunwoody polynomial determined by $D_n(3, 1, 2, 2, -1)$. Since

$$w(x_0, x_1, x_2, x_3, x_4) = x_1 x_2 x_3 x_4^{-1} x_3 x_2^{-1} x_2^{-1} x_1 x_0^{-1}$$

is independent of $n (> 4)$, it is a principal relation. Indeed that the Dunwoody (1, 1)-knot $K(3, 1, 2, 2)$ represents the knot 9_{42} in the knot table classified by Rolfsen. It is interesting to note that the Dunwoody polynomial $f_w^n(t)$ for $n > 4$ is the Alexander polynomial of 9_{42} .

For the Dunwoody (1, 1)-knot $K = K(a, b, c, r)$ in \mathbb{S}^3 , the following shows that $f_w^n(t)$ is to be the Alexander polynomial of K .

- If $w_k = w(x_0, x_1, \dots, x_k)$ is the principal relation of the Dunwoody 3-manifold represented by $D_n(a, b, c, r, s)$ for some n , then $f_w^n(t)$ is the Alexander polynomial of K in \mathbb{S}^3 .

In particular, the Dunwoody (1, 1)-knot $K = K(a, b, c, r)$ defined in (2.1) and (2.2) for $K = T(k, hk \pm 2)$ with $h, k > 0$ induces the Dunwoody 3-manifold represented by $D_n(a, b, c, r, s)$ for some s . Using the principal relation, say w , of $D_n(a, b, c, r, s)$, we can obtain the Dunwoody polynomial $f_w^n(t)$ such that $f_w^n(t) \doteq \Delta_K(t)$. For example, let K be a torus knot $T(5, 7)$ satisfying $7 \equiv 2 \pmod{5}$. On $D_n(2, 1, 12, 13, -5)$ with $n > 29$, we can obtain a relation w as the following

$$w = x_0^{-1} x_1^1 x_6^1 x_{11}^1 x_{16}^1 x_{17}^{-1} x_{12}^{-1} x_7^{-1} x_8^1 x_{13}^1 x_{18}^1 x_{23}^1 x_{24}^{-1}$$

$$x_{19}^{-1}x_{14}^{-1}x_{10}^{-1}x_5^{-1}.$$

Then the relation w is principal in $D_n(2, 1, 12, 13, -5)$ for condition $n > 29$. Thus it was shown in [13] that $f_w^n(t)$ is the Alexander polynomial of K .

For each knot K in \mathbb{S}^3 , we denote the projection of $\Delta_K(t)$ into $\mathbb{Z}[t]/(t^n - 1)$ with $\Delta_K^n(t)$. The following corollary shows the connections between the projection of Alexander polynomial into $\mathbb{Z}[t]/(t^n - 1)$ and the Dunwoody polynomial for the Dunwoody $(1, 1)$ -knot in \mathbb{S}^3 .

Corollary 3.2([4]). *Let $D(a, b, c, r)$ be the Dunwoody $(1, 1)$ -decomposition of (\mathbb{S}^3, K) and $n > 1$. Then $f_w^n(t) \doteq \Delta_K^n(t)$ in $\mathbb{Z}[t]/(t^n - 1)$, where \doteq means equal up to units.*

The following corollary is required the degree of the Alexander polynomial in order to obtain the Dunwoody polynomial.

Corollary 3.3([4]). *Let K be the Dunwoody $(1, 1)$ -knot representing $T(k, hk \pm 1)$ with $h, k > 0$ and $n > 1$. Suppose that $f_w^n(t)$ is the Dunwoody polynomial associated to the cyclic presentation obtained by applying Theorem 7 in [4]. Then $f_w^n(t) \doteq \Delta_K(t)$ in $\mathbb{Z}[t]/(t^n - 1)$ if $n > \deg(\Delta_K(t))$, where \doteq means equal up to units.*

For example, no more the result of Corollary 3.3 is true for $T(5, 7)$ and $\deg(\Delta_K(t)) = 24$. In fact, for $n = 25$, the relation w is not principal because x_{23} and x_{24}^{-1} in w are equal to x_{-2} and x_{-1}^{-1} under $D_{25}(2, 1, 12, 13, -5)$, respectively, that is, w is not independent of 25. Thus w is equal to the relation

$$x_0^{-1}x_1^1x_6^1x_{11}^1x_{16}^1x_{17}^{-1}x_{12}^{-1}x_7^{-1}x_8^1x_{13}^1x_{18}^1x_{-2}^{-1}x_{-1}^{-1}x_{19}^{-1}x_{14}^{-1}x_{10}^{-1}x_5^{-1}$$

on $D_{25}(2, 1, 12, 13, -5)$. In case of Corollary 3.3, we have to know the degree of $\Delta_K(t)$ in order to show that $f_w^n(t)$ is to be the Alexander polynomial of K . However, without the condition for the degree of $\Delta_K(t)$, we can show that $f_w^n(t)$ is to be the Alexander polynomial of the torus knot K (generally, the Dunwoody $(1, 1)$ -knot in \mathbb{S}^3) from properties itself.

As the main result of this section, we show that the Dunwoody polynomial is to be the Alexander polynomial. In other words we give the condition for n in order that $D_n(a, b, c, r, s)$ admits always the principal cyclic presentation.

Given p and q defined on $D(a, b, c, r)$ which is the Dunwoody $(1, 1)$ -decomposition determined by two permutations α and β such that $|\beta\alpha| = 2$, we recall that $D_n(a, b, c, r, s)$ satisfies $ps + q \equiv 0 \pmod n$ for some $n > 1$ and $s \in \mathbb{Z}$. First of all, we define a cyclic sequence from $D_n(a, b, c, r, s)$ as follows. We set

$$\begin{aligned} A^+ &= \{1, 2, \dots, a\}, \\ B^+ &= \{a + 1, a + 2, \dots, a + b\}, \\ C^+ &= \{a + b + 1, a + b + 2, \dots, a + b + c\}, \end{aligned}$$

$$\begin{aligned}
 E^+ &= \{a + b + c + 1, a + b + c + 2, \dots, a + b + c + a = d\}, \\
 A^- &= \{-1, -2, \dots, -a\}, \\
 C^- &= \{-a - 1, -a - 2, \dots, -a - c\}, \\
 B^- &= \{-a - c - 1, -a - c - 2, \dots, -a - c - b\}, \quad \text{and} \\
 E^- &= \{-a - c - b - 1, -a - c - b - 2, \dots, \\
 &\quad -a - c - b - a = -d\}.
 \end{aligned}$$

Then $A^+ \cup B^+ \cup C^+ \cup E^+ = X^+$ and $A^- \cup C^- \cup B^- \cup E^- = X^-$. For each $0 \leq i \leq n-1$, let C_i be the i -th meridian disk i of the Heegaard diagram $D_n(a, b, c, r, s)$ as in Figure 2, and \bar{C}_i the i -th meridian disk \bar{i} of the Heegaard diagram $D_n(a, b, c, r, s)$. For $0 \leq i \leq n-1$ and $1 \leq j \leq d$, a point (i, j) on $D_n(a, b, c, r, s)$ means the number j in i -th meridian disk C_i , and a point $(\bar{i}, -j)$ means the number $-j$ in i -th meridian disk \bar{C}_i . So if $(i, j) \in D_n(a, b, c, r, s)$ is a starting point at C_i , then $\theta^{n-1}(i, j) = (i + n - 1, j)$ is a starting point at $\theta^{n-1}(C_i)$. We define the rules corresponding to i on $D_n(a, b, c, r, s)$ and α on $D(a, b, c, r)$ by

$$(3.1) \quad \begin{cases} (i, a) \rightarrow (i + 1, \alpha(a)) & \text{if } a \in A^+ \\ (i, b) \rightarrow (\bar{i} + s + 1, \alpha(b)) & \text{if } b \in B^+ \\ (i, c) \rightarrow (\bar{i} + s, \alpha(c)) & \text{if } c \in C^+ \\ (i, e) \rightarrow (i - 1, \alpha(e)) & \text{if } e \in E^+ \end{cases} .$$

The rules corresponding to \bar{i} on $D_n(a, b, c, r, s)$ and α on $D(a, b, c, r)$ are defined by

$$(3.2) \quad \begin{cases} (\bar{i}, -a) \rightarrow (\bar{i} + 1, \alpha(-a)) & \text{if } -a \in A^- \\ (\bar{i}, -c) \rightarrow (i - s, \alpha(-c)) & \text{if } -c \in C^- \\ (\bar{i}, -b) \rightarrow (i - (s + 1), \alpha(-b)) & \text{if } -b \in B^- \\ (\bar{i}, -e) \rightarrow (\bar{i} - 1, \alpha(-e)) & \text{if } -e \in E^- \end{cases} .$$

Moreover, the identification between i -th meridian disk C_i and i -th meridian disk \bar{C}_i on $D_n(a, b, c, r, s)$ is defined by

$$(3.3) \quad \begin{cases} (i, x) \rightarrow (\bar{i}, \beta(x)) & \text{if } x \in X^+ \\ (\bar{i}, -x) \rightarrow (i, \beta(-x)) & \text{if } -x \in X^- \end{cases} .$$

By the property of the n -fold strongly-cyclic branched covering space, we have the following.

Lemma 3.4. *Let $(0, 1)$ be a starting point on $D_n(a, b, c, r, s)$ and $d = 2a + b + c$. Then we have $(\beta\alpha)^d(0, 1) = (ps + q, 1)$.*

Proof. From α and β defined in Theorem 2.1, $\beta\alpha$ with length d determines the simple closed curve in $D(a, b, c, r)$ with the starting point $(0, 1)$. The simple closed curve is lifted to n simple closed curves on $D_n(a, b, c, r, s)$ which is determined by (3.1), (3.2) and (3.3). For $0 \leq i \leq n-1$ and $1 \leq j \leq d$, if $(i, j) \in D_n(a, b, c, r, s)$ is

a starting point of a curve of the n simple closed curves on $D_n(a, b, c, r, s)$, we have $(\beta\alpha)^d(i, j) = (ps + q + i, j)$ because of $ps + q \equiv 0 \pmod n$. In particular, let $(0, 1)$ be a starting point on $D_n(a, b, c, r, s)$. Then the proof follows from the above result. \square

For $0 \leq i \leq n - 1$ and $1 \leq j \leq d$, if $(i, j) \in D_n(a, b, c, r, s)$ is a starting point, we have a sequence

$$(i, j) \rightarrow (\beta\alpha)(i, j) \rightarrow (\beta\alpha)^2(i, j) \cdots \rightarrow (\beta\alpha)^{d-1}(i, j) \rightarrow (\beta\alpha)^d(i, j) = (ps + q + i, j).$$

The sequence from (i, j) to $(ps + q + i, j)$ determined by (3.1), (3.2) and (3.3) is called a *cyclic sequence* of $D_n(a, b, c, r, s)$. We note that the cyclic sequences of $D_n(a, b, c, r, s)$ are independent of the choice of the starting points on itself.

We now suppose that $(0, 1)$ is a starting point which is the number 1 in 0-th meridian disk of $D_n(a, b, c, r, s)$. Since $1 \in A^+$ and $\alpha(1) = d$, we have $(0, 1) \rightarrow (1, d)$ by (3.1). Since $r < d$, $\beta(d) = -d + r$ and so $(1, d) \rightarrow (\bar{1}, -d + r)$ by (3.3). Thus $(0, 1) \rightarrow (\bar{1}, -d + r)$ under $\beta\alpha$, or $\beta\alpha(0, 1) = (\bar{1}, -d + r)$. Applying repeated process, we obtain $(\beta\alpha)^d(0, 1) = (ps + q, 1)$ by Lemma 3.4. We define a relation

$$w = x_0 x_{\beta\alpha(0)}^{\pm 1} x_{(\beta\alpha)^2(0)}^{\pm 1} x_{(\beta\alpha)^3(0)}^{\pm 1} \cdots x_{(\beta\alpha)^{d-1}(0)}^{\pm 1}$$

on $D_n(a, b, c, r, s)$ induced by the cyclic sequence of $D_n(a, b, c, r, s)$, where

$$x_{(\beta\alpha)^k(0)}^{\pm 1} = \begin{cases} x_{(\beta\alpha)^k(0)} & \text{if } (\beta\alpha)^k(0) = i \\ x_{(\beta\alpha)^k(0)}^{-1} & \text{if } (\beta\alpha)^k(0) = \bar{i}. \end{cases}$$

If $(\beta\alpha)^k(0) = \bar{-i}$ and $(\beta\alpha)^k(0) = -i$, then $x_{(\beta\alpha)^k(0)}^{\pm 1} = x_{-i}^{-1}$ and $x_{(\beta\alpha)^k(0)}^{\pm 1} = x_{-i}$, respectively. We can assume that $(\beta\alpha)^k(0) \geq 0 \pmod n$ for all $1 \leq k \leq d$. For each $0 \leq i \leq n - 1$, we note that $\theta^i(w)$ has the starting point $(i, 1)$ and the final point $(ps + q + i, 1)$ with $(\beta\alpha)^d(i, 1) = (ps + q + i, 1)$. Thus the abelianized word of w induces *the Dunwoody polynomial*

$$f_w^n(t) = t^0 \pm t^{\beta\alpha(0)} \pm t^{(\beta\alpha)^2(0)} \pm \cdots \pm t^{(\beta\alpha)^{d-1}(0)}$$

by substituting $-t^{-i}$ into x_{-i}^{-1} . If $|(\beta\alpha)^k(0)| < n$ for each $1 \leq k \leq d - 1$, then w is the principal relation of the cyclic presentation of $D_n(a, b, c, r, s)$ and we have $\text{deg}(f_w^n(t)) = M^+ - M^-$ where $M^+ = \max_{0 \leq k \leq d-1} \{(\beta\alpha)^k(0)\}$ and $M^- = \min_{0 \leq k \leq d-1} \{(\beta\alpha)^k(0)\}$.

Suppose that $D(a, b, c, r)$ is the Dunwoody $(1, 1)$ -decomposition representing a $(1, 1)$ -knot K in \mathbb{S}^3 . Since $p = \pm 1$ and $ps + q = 0$, $s = \mp q$. For each $n > 1$, there exists the Dunwoody 3-manifold represented by $D_n(a, b, c, r, s)$, which is the n -fold (strongly-) cyclic covering of \mathbb{S}^3 branched over K . By Lemma 3.4, the cyclic sequence of $D_n(a, b, c, r, s)$ has $(\beta\alpha)^d(0, 1) = (0, 1)$. Since each $\{C_i, \bar{C}_{i+s}\}$

in $D_n(a, b, c, r, s)$ is connected by c edges, the relation w is independent of n if $n > M^+ - M^- + |s|$. Therefore $f_w^n(t)$ is the Alexander polynomial of the Dunwoody (1, 1)-knot K in \mathbb{S}^3 if $n > M^+ - M^- + |s|$. We remark that there is a natural way to obtain the Dunwoody polynomial $f_w^n(t) \in \mathbb{Z}[t]/(t^n - 1)$ associated to the Dunwoody (1, 1)-knot K in \mathbb{S}^3 because of the uniqueness of s in \mathbb{Z}_n with $ps + q \equiv 0 \pmod n$. Summarizing, we have proved the following.

Theorem 3.5. *Let $D(a, b, c, r)$ be the Dunwoody (1, 1)-decomposition of (\mathbb{S}^3, K) , and α and β be two transpositions defined in Theorem 2.1. Let $w(x_0, \dots, x_{n-1})$ be a relation induced by the cyclic sequence of $D_n(a, b, c, r, \mp q)$ for $n > 1$, $M^+ = \max_{0 \leq k \leq d-1} \{(\beta\alpha)^k(0)\}$ and $M^- = \min_{0 \leq k \leq d-1} \{(\beta\alpha)^k(0)\}$. Then $f_w^n(t)$ is the Alexander polynomial of K if $n > M^+ - M^- + |s|$.*

We give two canonical examples as follows.

Example 3.

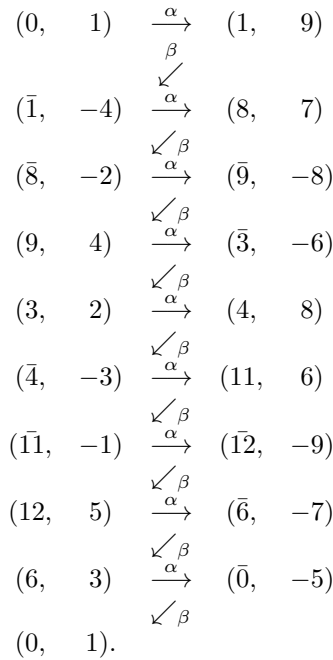

Let $D(2, 3, 2, 5)$ be a Dunwoody (1, 1)-decomposition. Then we obtain $p = 1$ and $q = 7$ from an oriented curve on $D(2, 3, 2, 5)$ defined in section 2. Since $p = 1$, it is representing a Dunwoody (1, 1)-knot $K(2, 3, 2, 5)$ in \mathbb{S}^3 . Since $q = 7$, we have $s = -7$. Therefore, for all $n > 1$, there exists a Dunwoody 3-manifold represented by $D_n(2, 3, 2, 5, -7)$. In order to show a principal relation on $D_n(2, 3, 2, 5, -7)$ we need a cyclic sequence as above. For a Dunwoody (1, 1)-decomposition $D(2, 3, 2, 5)$, setting $A^+ = \{1, 2\}$, $B^+ = \{3, 4, 5\}$, $C^+ = \{6, 7\}$, $E^+ = \{8, 9\}$, and $A^- = \{-1, -2\}$, $C^- = \{-3, -4\}$, $B^- = \{-5, -6, -7\}$, and $E^- = \{-8, -9\}$, then we have $A^+ \cup B^+ \cup$

$C^+ \cup E^+ = X^+$ and $A^- \cup C^- \cup B^- \cup E^- = X^-$. Let $(0, 1)$ be the starting point on $D_n(2, 3, 2, 5, -7)$. Then we have a cyclic sequence by applying (3.1), (3.2) and (3.3) as above. Thus the relation w induced by the above cyclic sequence is

$$w = x_0 x_1^{-1} x_8^{-1} x_9 x_3 x_4^{-1} x_{11}^{-1} x_{12} x_6$$

and the Dunwoody polynomial $f_w^n(t)$ is

$$f_w^n(t) = 1 - t + t^3 - t^4 + t^6 - t^8 + t^9 - t^{11} + t^{12}.$$

Since $M^+ = 12$ and $M^- = 0$, the relation w on $D_n(2, 3, 2, 5, -7)$ is principal for $n > 19$. In fact, $f_w^n(t)$ is the Alexander polynomial of $K(2, 3, 2, 5)$ representing $T(3, 7)$, which can be obtained by considering the principal cyclic presentation of $D_{20}(2, 3, 2, 5, -7)$.

Example 4.

$$\begin{array}{ccc} (0, & 1) & \xrightarrow{\alpha} (1, & 9) \\ & & \swarrow_{\beta} \\ (\bar{1}, & -3) & \xrightarrow{\alpha} (-2, & 4) \\ & & \swarrow_{\beta} \\ (\bar{-2}, & -7) & \xrightarrow{\alpha} (-6, & 3) \\ & & \swarrow_{\beta} \\ (\bar{-6}, & -6) & \xrightarrow{\alpha} (-9, & 7) \\ & & \swarrow_{\beta} \\ (\bar{-9}, & -1) & \xrightarrow{\alpha} (\bar{-8}, & -9) \\ & & \swarrow_{\beta} \\ (-8, & 6) & \xrightarrow{\alpha} (\bar{-5}, & -5) \\ & & \swarrow_{\beta} \\ (-5, & 2) & \xrightarrow{\alpha} (-4, & 8) \\ & & \swarrow_{\beta} \\ (\bar{-4}, & -2) & \xrightarrow{\alpha} (\bar{-3}, & -8) \\ & & \swarrow_{\beta} \\ (-3, & 5) & \xrightarrow{\alpha} (\bar{0}, & -4) \\ & & \swarrow_{\beta} \\ (0, & 1). \end{array}$$

Let $D(2, 1, 4, 6)$ be a Dunwoody $(1, 1)$ -decomposition with $p = -1$ and $q = 3$. Since $ps + q = 0$, there exists a Dunwoody 3-manifold represented by $D_n(2, 1, 4, 6, 3)$ for all $n > 1$. To obtain a principal relation for $D_n(2, 1, 4, 6, 3)$, we need a cyclic sequence as above. For $D(2, 1, 4, 6)$, setting $A^+ = \{1, 2\}$, $B^+ = \{3\}$, $C^+ = \{4, 5, 6, 7\}$, $E^+ = \{8, 9\}$, and $A^- = \{-1, -2\}$, $C^- = \{-3, -4, -5, -6\}$, $B^- = \{-7\}$, and $E^- = \{-8, -9\}$, then we have $A^+ \cup B^+ \cup C^+ \cup E^+ = X^+$ and $A^- \cup C^- \cup B^- \cup E^- = X^-$. By applying (3.1), (3.2) and (3.3), we have a cyclic sequence as above. Thus we have a relation

$$w = x_1 x_{-2} x_{-6} x_{-9} x_{-8}^{-1} x_{-5}^{-1} x_{-4} x_{-3}^{-1} x_0^{-1}.$$

Hence the Dunwoody polynomial is

$$f_w^n(t) = t^{-9}(1 - t + t^3 - t^4 + t^5 - t^6 + t^7 - t^9 + t^{10}).$$

Since $M^+ = 1$ and $M^- = -9$, the relation w on $D_n(2, 1, 4, 6, 3)$ is principal for $n > 13$, so $f_w^n(t)$ is the Alexander polynomial of $K(2, 1, 4, 6)$ representing the pretzel knot $P(-2, 3, 7)$, which can be obtained by considering the principal cyclic presentation of $D_{14}(2, 1, 4, 6, 3)$.

The next corollaries are immediate consequences of the previous considerations.

Corollary 3.6. *Let $D(a, b, c, r)$ be the Dunwoody (1, 1)-decomposition of (\mathbb{S}^3, K) . Suppose that α and β are two permutations defined by Theorem 2.1. Let $w(x_0, \dots, x_k)$ be a relation induced by the cyclic sequence of $D_n(a, b, c, r, \mp q)$ for each $n > 1$, $M^+ = \max_{0 \leq k \leq d-1} \{(\beta\alpha)^k(0)\}$ and $M^- = \min_{0 \leq k \leq d-1} \{(\beta\alpha)^k(0)\}$, where $d = 2a + b + c$. Then $f_w^n(t)$ is the Alexander polynomial of K if n is the smallest positive integer n_0 such that $n_0 > M^+ - M^- + |s|$.*

Let $T(i, j)$ be the torus knot such that $2 \leq i \leq j$ and $j = \bar{j} + ik$ for some $k \in \mathbb{Z}$. Let $\bar{j} = \pm 1$, then the following (\star) is the families of the Dunwoody 3-manifolds and their branched sets $T(i, j)$, where $i \geq 3$ and $k \geq 1$. Note that these are different with the families introduced in [4]. As applications of Theorem 3.5, for the Dunwoody (1, 1)-knots representing $T(k_1, k_2)$ satisfying $k_2 \equiv \pm 1 \pmod{k_1}$ as

$$T(i, ki + 1) \leftrightarrow D_n(1, i - 2, (i - 1) + (k - 1)(2i - 2), (i - 1) + (k - 1)(2i - 2), i)$$

$$T(i, (k + 1)i - 1) \leftrightarrow D_n(1, i - 2, (3i - 5) + (k - 1)(2i - 2), 3i - 4, -i) \quad (\star)$$

and $k_2 \equiv \pm 2 \pmod{k_1}$ as (2.1) or (2.2), we show their Alexander polynomial and certain invariant. In our case Corollary 3.3 can be modified as follows.

Corollary 3.7. *Let $K = K(a, b, c, r)$ be the Dunwoody (1, 1)-knot as in (\star) and $n > 1$. Then $f_w^n(t) \doteq \Delta_K(t)$ if $n > M^+ - M^- + |s|$, where \doteq means equal up to units.*

For the Dunwoody (1, 1)-knots satisfying (2.1) or (2.2), we have the following.

Corollary 3.8. *Let $K = K(a, b, c, r)$ be the Dunwoody (1, 1)-knot representing $T(k_1, k_2)$ with $k_2 \equiv \pm 2 \pmod{k_1}$ as in (2.1) or (2.2). Then $f_w^n(t) \doteq \Delta_K(t)$ if $n > M^+ - M^- + |s|$, where \doteq means equal up to units.*

We suppose that $K(a, b, c, r)$ is the Dunwoody (1, 1)-knot representing $T(k_1, k_2)$ satisfying $k_2 \equiv \pm 1$ or $\pm 2 \pmod{k_1}$ as (\star) or (2.1) and (2.2). Then the following shows that $d = 2a + b + c$ is an invariant for $K(a, b, c, r)$.

Theorem 3.9. *Let $T(k_1, k_2)$ be the torus knot with $k_2 \equiv \pm 2 \pmod{k_1}$ as in (2.1) or (2.2). Then d is an invariant of $T(k_1, k_2)$, where*

$$d = \begin{cases} k_1 + \frac{(k_1^2-1)(k_2-2)}{2k_1} & \text{if } k_2 \equiv 2 \pmod{k_1} \\ k_1 + \frac{k_1^2(k_2-2)-(k_2+2)}{2k_1} & \text{if } k_2 \equiv -2 \pmod{k_1} \end{cases} .$$

Proof. We suppose that $T(k_1, k_2)$ be the torus knot with $k_2 \equiv \pm 2 \pmod{k_1}$. Then the Dunwoody 3-manifold represented by $D_n(a, b, c, r, s)$ satisfies (2.1) or (2.2). Let $n > M^+ - M^- + |s|$. On $D_n(a, b, c, r, s)$, we have a principal relation w from a cyclic sequence by applying (3.1), (3.2) and (3.3). Thus the Dunwoody polynomial $f_w(t)$ of degree $M^+ - M^-$ is the Alexander polynomial of $T(k_1, k_2)$, and $M^+ - M^- = (k_1 - 1)(k_2 - 1)$. Since the length of w is d , the number of terms of $\Delta(k_1, k_2)$ is $d = 2a + b + c$. Therefore d is an invariant of $T(k_1, k_2)$. \square

For (\star) , the similar argument can be applied as the following.

Corollary 3.10. *Let $T(i, j)$ be the torus knot with $3 \leq i \leq j$ and $j = ki \pm 1$ for some $k \geq 1$ in \mathbb{Z} . Then d is an invariant of $T(i, j)$, where*

$$d = \begin{cases} (2i - 1) + (k - 1)(2i - 2) & \text{if } j = ki + 1 \\ (4i - 5) + (k - 1)(2i - 2) & \text{if } j = ki - 1 \end{cases} .$$

We recall that if $\Delta_K^n(t) \in \mathbb{Z}[t]/(t^n - 1)$ is the projection of the Alexander polynomial of $K = K(a, b, c, r)$, then there is a connection between $f_w^n(t)$ and $\Delta_K^n(t)$, which follows from the result of Theorem 4.1 in [3].

Corollary 3.11. *Let $K = K(a, b, c, r)$ be a $(1, 1)$ -knot in the lens space $L(p, q')$ and $H_1(L(p, q') - K) = \mathbb{Z} \oplus \mathbb{Z}_{\bar{d}}$, where $\bar{d} = \gcd(p, q)$. Then for each $n > 1$ such that $\gcd(n, p) = 1$, we have*

$$f_w^n(t^{p/\bar{d}}) = \Delta_K^n(t) \cdot \frac{(t^{p/\bar{d}} - 1)}{(t - 1)}$$

up to units of $\mathbb{Z}[t]/(t^n - 1)$.

In Corollary 3.11, the cyclotomic polynomial

$$\frac{(t^{p/\bar{d}} - 1)}{(t - 1)} = 1 + t + t^2 + \dots + t^{p/\bar{d}-1}$$

is *irreducible polynomial* if p/\bar{d} is prime. Let $n > 1$ and $\gcd(p, n) = 1$. Then the following example explains one way to obtain the Alexander polynomial of $K(a, b, c, r)$ in $L(p, q')$ from the Dunwoody polynomial on $D_n(a, b, c, r, s)$ with $ps + q \equiv 0 \pmod{n}$.

Example 5. Let $D(1, 5, 0, 6)$ be a $(1, 1)$ -decomposition with $p = 5$ and $q = 7$ and

$K = K(1, 5, 0, 6)$ a (1, 1)-knot in the lens space $L(5, 1)$. Then there is a unique $s \in \mathbb{Z}_{12}$ such that $5s + 7 \equiv 0 \pmod{12}$. On $D_{12}(1, 5, 0, 6, 1)$ we have a principal relation

$$w = x_0x_1^{-1}x_2x_4x_6x_8x_{10}$$

induced by a cyclic sequence as follow:

$$\begin{array}{ccc} (0, & 1) & \xrightarrow{\alpha} (1, & 7) \\ & & \swarrow \beta & \\ (\bar{1}, & -1) & \xrightarrow{\alpha} (\bar{2}, & -7) \\ & & \swarrow \beta & \\ (2, & 6) & \xrightarrow{\alpha} (\bar{4}, & -6) \\ & & \swarrow \beta & \\ (4, & 5) & \xrightarrow{\alpha} (\bar{6}, & -5) \\ & & \swarrow \beta & \\ (6, & 4) & \xrightarrow{\alpha} (\bar{8}, & -4) \\ & & \swarrow \beta & \\ (8, & 3) & \xrightarrow{\alpha} (\bar{10}, & -3) \\ & & \swarrow \beta & \\ (10, & 2) & \xrightarrow{\alpha} (\bar{12}, & -2) \\ & & \swarrow \beta & \\ (12, & 1). & & \end{array}$$

Thus we obtain the Dunwoody polynomial

$$\begin{aligned} f_w^{12}(t) &\doteq 1 + t^2 + t^4 + t^6 + t^8 + t^{10} - t^{-1} \\ &\doteq 1 + t^2 + t^4 + t^6 + t^8 + t^{10} - t^{11}. \end{aligned}$$

By Corollary 3.11, putting $t^{p/\bar{d}} = t^5$, we have

$$\begin{aligned} f_w^{12}(t^5) &\doteq 1 + t^{10} + t^{20} + t^{30} + t^{40} + t^{50} - t^{55} \\ &\doteq t^{-10}(1 + t^4 - t^5 + t^6 + t^2 + t^8 + t^{10}) \\ &= (1 - t + t^2 - t^3 + t^4 - t^5 + t^6) \\ &\quad \cdot (1 + t + t^2 + t^3 + t^4) \\ &= (1 - t + t^2 - t^3 + t^4 - t^5 + t^6) \frac{(t^5 - 1)}{(t - 1)}. \end{aligned}$$

and so $\Delta_K^{12} = 1 - t + t^2 - t^3 + t^4 - t^5 + t^6$ is the Alexander polynomial of the (1, 1)-knot $K(1, 5, 0, 6)$, where the multiplication for t^{10} requires condition $n > 10$.

Indeed we have the same result from $D_{22}(1, 5, 0, 6, 3)$. However the Dunwoody polynomial induced by $D_7(1, 5, 0, 6, 0)$ does not give the Alexander polynomial of the (1, 1)-knot $K(1, 5, 0, 6)$ because of $7 < 10$. In other words, the Dunwoody polynomial induced by $D_7(1, 5, 0, 6, 0)$ is not the Alexander polynomial of the (1, 1)-knot $K(1, 5, 0, 6)$. From this example, we may have the possibility that the Alexander

polynomial of the Dunwoody $(1, 1)$ -knot in a lens space can be obtained from the Dunwoody polynomial.

References

- [1] H. Aydin, I. Gultekin and M. Mulazzani, *Torus knots and Dunwoody manifolds*, Siberian Math. J., **45**(2004), 1-6.
- [2] J. W. Alexander, *Topological invariants of knots and links*, Amer. Math. Soc., **20**(1923), 275-306.
- [3] A. Cattabriga, *The Alexander polynomial of $(1, 1)$ -knots*, J. Knot Theory its Ramifications, **15**(9)(2006), 1119-1129.
- [4] A. Cattabriga and M. Mulazzani, *Strongly-cyclic branched coverings of $(1, 1)$ -knots and cyclic presentations of groups*, Math. Proc. Camb. Phil. Soc., **135**(2003), 137-146.
- [5] A. Cattabriga and M. Mulazzani, *All strongly-cyclic branched coverings of $(1, 1)$ -knots are Dunwoody manifolds*, J. London Math. Soc., **70**(2004), 512-528.
- [6] A. Cattabriga and M. Mulazzani, *Representations of $(1, 1)$ -knots*, Fund. Math., **118**(2005), 45-57.
- [7] A. Cattabriga, M. Mulazzani and A. Vesnin, *Complexity, Heegaard diagrams and generalized Dunwoody manifolds*, J. Korean Math.Soc., **47**(3)(2010), 585-599.
- [8] A. Cavicchioli, B. Ruini and F. Spaggiari, *On a conjecture of M.J.Dunwoody*, Algebra Coll., **8**(2)(2001), 169-218.
- [9] R. H. Crowell and R. H. Fox, *Introduction to Knot Theory*, Springer-Verlag, Berlin, (1963).
- [10] M. J. Dunwoody, *Cyclic presentations and 3-manifolds*, Proc. Inter. Conf., Group-Korea '94, Walter de Gruyter, Berlin-New York (1995), 47-55.
- [11] L. Grasselli and M. Mulazzani, *Genus one 1-bridge knots and Dunwoody manifolds*, Forum Math., **13**(2001), 379-397.
- [12] S. H. Kim, *On spatial theta-curves with the same $(Z_2 \oplus Z_2)$ -fold and 2-fold branched covering*, Note di Mathematica, **23**(1)(2004/2005), 111-122.
- [13] S. H. Kim and Y. Kim, *Torus knots and 3-manifolds*, J. Knot Theory and its Ram., **13**(8)(2004), 1103-1119.
- [14] S. H. Kim and Y. Kim, *On the 2-bridge knots of Dunwoody $(1, 1)$ -knots*, Bull. Korean Math. Soc., **48**(1)(2011), 197-211.
- [15] S. H. Kim and Y. Kim, *On the generalized Dunwoody 3-manifolds*, Osaka Journal of Mathematics, to appear.
- [16] M. Mulazzani, *Cyclic presentations of groups and cyclic branched coverings of $(1, 1)$ -knots*, Bull. Korean Math. Soc., **40**(1)(2003), 101-108.
- [17] L. Neuwirth, *An algorithm for the construction of 3-manifolds from 2-complexes*, Proc. Camb. Phil. Soc., **64**(1)(1968), 603-613.

- [18] D. Rolfsen, *Knots and Links*, Math. Lect. Series, Vol.7, Berkeley, Publish or Perish inc., (1976).
- [19] H. J. Song and S. H. Kim, *Dunwoody 3-manifolds and $(1, 1)$ -decomposable knots*, Proc. Workshop in pure math (edited by Jongsu Kim and Sungbok Hong), **19**(2000), 193-211.
- [20] V. G. Turaev, *The Alexander polynomial of a three-dimensional manifold*, USSR Sbornik, **26**(1975), 313-329.
- [21] V. G. Turaev, *Introduction to Combinatorial Torsions*, Birkhauser, Basel, Boston, Berlin, 2001.