

A Personalized Healthcare Analysis System in Ubiquitous Environment

Mangal Sain, Wan-Young Chung, and Hoon-Jae Lee*, *Member, KIMICS*

Abstract— With the recent trends and the adaptation of further advancement in personal healthcare system leads to develop some application which can work independent and user can operate that application without much interference of physician or any specialist user. To meet these needs, this paper proposes and implements a progressive architecture for the personal healthcare information system. This new architecture will not only play the role of middleware but also provide a analysis tool to process that different sensor data which is collected from different sensors implemented on patient body and environment. After collecting that data, with the help of various developed applications this data can be convert into useful information which will be stored in application server for further use and research. These features can be enabled by simple and effortless interactions of normal users and act autonomously to support their activities. This proposed personal healthcare architecture will also provide analysis report to the doctors and patient or various users for further instructions. The analysis report consists of healthcare data analysis results and history of patients. We are considering healthcare data like ECG, which is an important aspect for basic healthcare need.

Index Terms— Personal Healthcare Information system, Middleware, Ubiquitous Healthcare, Healthcare monitoring etc.

I. INTRODUCTION

IN the last few years, internet technology and its applications has grown rapidly beyond servers, desktop and laptop to include handheld devices like PDA, mobile, smart phones etc. This trend will be continue until these devices and application will not be simpler and centralized to devices such as sensors, home appliances, personal medical devices and which will be connected through Internet. The relation between the volume of centralized and distributed functionality may be taken as a

measure for characterizing the degree of personal healthcare system. A middleware suggests that it is software positioned between the operating system and the application just like body of car which hide all the complexity of all engine parts and internal architecture, which spreads itself over a heterogeneous internal architecture, concealing the complexity of the underlying technology from the application being run on it. So middleware can be viewed as set of service which can access through their API (application programming interface) provided by several research organization and other institutes.

Every healthcare application requirements are different from existing or non existing application. To build such application several existing application and ongoing projects were studied and then tried to build an architecture which can be appropriate to handle necessary information related to personal healthcare. In this paper we design a prototype for ubiquitous healthcare data analysis and monitoring using multiple wireless sensors for personal healthcare system. This proposed architecture will also provide a tool to the doctors and patient as well as nurses to analyze healthcare data. The analysis report will consist of healthcare data analysis results and history of patient. This paper considered healthcare data like ECG, Accelerometer and temperature.

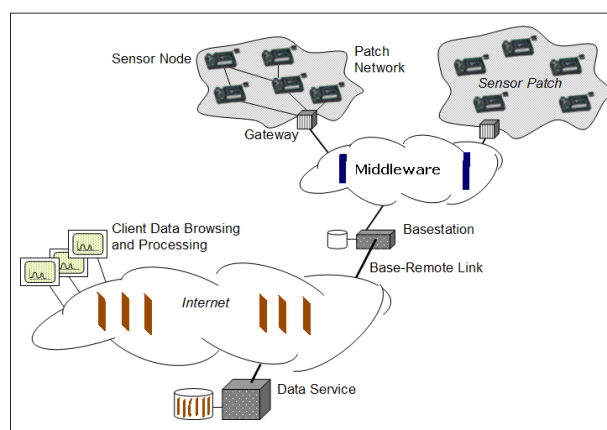

Fig. 1. Personal healthcare communication system architecture.

Figure 1 illustrates common communication architecture for ubiquitous healthcare system, which also includes a progressive middleware between client and various sensor nodes. In this architecture various sensor

Manuscript received February 28, 2011; revised March 10, 2011; accepted March 24, 2011.

Mangal Sain is with the Department of Ubiquitous IT, Dongseo University, Busan 617-716, Korea

WanYoung Chung is with the Department of Electronic Engineering, Pukyong National University, Busan 608-737, Korea

HoonJae Lee is with the Division of Computer and Information Engineering, Dongseo University, Busan, 617-716, Korea (Email: hjlee@dongseo.ac.kr)

* Corresponding Author

which are deployed in patient body or different location collects the healthcare and environmental data and sends to base station which connect to particular device or system. After receiving that data at base station it send to server for further analysis. To receive data from base station and to process that data into useful information a novel middleware is needed which can fulfill several other requirement which needed for this application. With the help of several developed application module which will explain later, data will be processed into useful information and later that information will be sent to server and physician application for further use. In this middleware a interface is developed which provide a platform to user where they can register, login, and feed their personal and healthcare data anytime anywhere. With the help of this module they can also compare their current health status with old health status if they already register with this application before.

In this paper the main concern is on system architecture, application development, availability of tools and their utilization and creates an interface between data source and GUI. We also overview a variety of related available technology and argue that no existing approach provides all the management tools required by sensor network applications. We also build a LiveGraph [1] with oracle to process different ubiquitous healthcare application's data and process that data into useful information, which played an important role in decision making. Application developers mostly rely on third party middleware, tools and libraries to respond the emerging trends of their target domain. With this middleware we tried to enhance the efficiency of application in data processing and decision making by put it on another web module which is independent of each application.

The rest of the paper is organised as follows, section 2 briefly describes related work and some existing technologies which are working on same fields and contributed allot. In section 3 describe the various design issue architecture developed for whole application. Section 4 discuss about implementation of the middleware in personal healthcare system and their performance analysis with compare to some existing application like MATLAB. Finally, in Section 5, we make some concluding remarks and present what can be the future work for this proposal.

II. RELATED WORK

Personal Healthcare information system is one of the most emerging areas of research these days; there are several personal and public healthcare research group and society which are working on healthcare information system and management. OpenEHR [2], HiMSS [3], HL7 [4] are some of them which are

working from many years and developing latest trends and technologies. OpenEHR stored a person's all health data once in a lifetime, which is vendor-independent and person centered. Their main focus is on message standards such as ISO13606, rather than exchange of data between EHR-systems. In HiMSS, the EHR is a longitudinal electronic record of patient health information generated by one or more encounters in any care delivery setting which also includes several information such as patient demographics, progress notes, problems, medications, vital signs, past medical history, immunizations, laboratory data and radiology reports. HL7 and its other member also provide a framework for exchange information, integration, sharing and retrieval of information. It enables interoperability of healthcare information which creates standard for the exchange, management, and integration of electronic healthcare information.

Due to recent trends in healthcare technology and huge impact on health economy, there is huge demand of different biomedical application and devices come to edges. There is huge work to be done on Personal healthcare information system and embedded devices and service provided by them. There is big need to build such advanced application which can reduce the cost of big application and can reduce the cost of big applications like computer tomographs (CT), magnetic resonance imaging (MRI) tomographs, anesthesia workstations or dialysis machines. All above devices and equipments are still builds and developed for mainly clinical setting, and for professional use and by only big industries.

The requirement to build this kind of application arises when we analyze that the population aging has become one of the most significant demographic processes of modern times. An inevitable consequence of the demographic transition and the shift to lower fertility and reduced mortality, the ageing of the world's population has many countries facing unprecedented numbers and proportions of older persons. In much of the world, populations are ageing at an extremely rapid pace. The proportion of older persons that is those aged 65 years and over, currently comprises around 10 per cent of the world's population, and is projected to increase to 22 percent by 2050 [5].

Platform such as CORBA, DCOM and RMI offer higher level distributed programming models that extend the native OS network environment. To get the maximum benefit of ubiquitous healthcare system it is necessary to build a middleware between different applications which can play an important role with management of data and information processing in personal healthcare information system. The

technology requirements of various domains are increasing, such as distributed platforms are commonly in use, the quality of service requirements for ubiquitous healthcare systems are also increasing as the low level sensor network grows powerful, customers also needs for platform independent software and interoperability.

The whole application is developed after study various existing application such as CAMUS [6] a middleware for providing context-aware applications with development and execution methodology which respond in a timely fashion to contexts. Another existing work is MiLAN [7] provide higher level of abstractions of complex low-level concepts to application programmers, easing the design and implementation of applications, however, sensor networks have some unique characteristics, including dynamic availability of data sources and application quality of service requirements that are not common to other types of applications. Yet another interesting work is proposed and implemented in OSGi - based Reconfigurable RFID Middleware [8] which proposes the service component framework and components design method for reconfigurable RFID middleware, and designs the basic service components of RFID middleware. We also analyze various different existing middleware which may be low level and high level middleware technology MOBIWARE [9], LIME [10] etc and try to find the best solution for healthcare information system.

III. SYSTEM DESIGN

The emergence of minuscule wireless sensor devices and advancement in security features has opened up a tremendous opportunity for improving the next generation smart healthcare devices and several applications which can certainly improve the quality of normal life through advanced healthcare. This can be achieved by deploying wireless body area network (WBAN) that typically consists of a gateway and a number of sensor devices attached strategically to a human body [11]. In this paper the main motive was to build a personalized healthcare information system which can play an important role in personal healthcare system. Normally a middleware in any personal healthcare system can provide an interface for different users and devices, but in this system with the interface it will also provide an analyzing tool to process different kind of data. To achieve this functionality this system builds some application modules. This system has three modules, first module known as personal healthcare module consist of *MedRec* which handle all kind of user activity. It provides an interactive GUI to various users to feed his/her data and to access old information and instruction. There are several sub modules according to various users such as physician,

patient, nurse etc. according to their authentication each of them access their specified module. Second module is information processing module where all data processed with the help of LiveGraph and oscilloscope. This is the most important phase of this application where all information processing done. After collecting sensor data from sensor in USN environment, data is sent to application with USN sensor mote. Third module is application database, where all the data and information stored after processing.

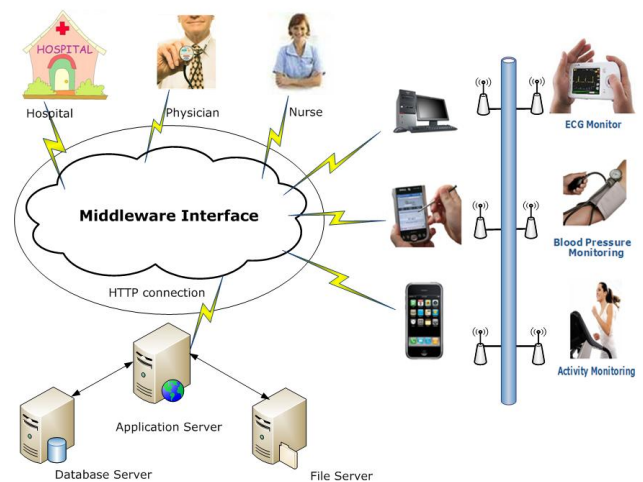

Fig. 2. Personal healthcare system in USN.

Figure 2, illustrates the system architecture of personal healthcare system in ubiquitous environment which consist of several application such ECG monitor, blood pressure monitoring and activity monitoring through desktop, PDA and smart phone in wireless network as well as wired network. A middleware interface provides an interactive environment between database and different application as well as different users. A user can access this system from anywhere through internet and according to their authenticity and authorization he can feed the data and also analyze if he is permitted to. As this application is build with J2EE technology and based on Model-view-controller (MVC) [12], which provides a pattern for separating the presentation logic(view), business logic(control), and data objects, so with a little modification we can implement this application and middleware on any other application too. To process and execute all application data and information this system use application server [13, 14] which reduce the memory, execution time and reduce the load on web application due that it increase lot of speed and performance of each application.

Our design prototype is developed for all computer

users which can be anywhere in the world which consist a web base application and connected to application server application server which is accessible through internet. To build user interface we use J2EE and swing. To make this application available all around we use J2EE technologies in which is easier to develop web front ends with enhancements to Java Servlets, Java Server Pages (JSP) and XML Schema which can also be used by developers to validate their XML structures.

To build a web application for a common interface between different application users and data source and various healthcare applications, J2EE technology with eclipse as IDE is used. The architecture shown in Figure 3 demonstrates a client application that connects to Weblogic Server through various resources adopter. To achieve a standard system-level plugability between Weblogic Server and different application, Weblogic Server has implemented the standard set of system-level contracts defined by the J2EE Connector Architecture. These contracts consist of SPI classes and interfaces that are required to be implemented in the application server and the various clients, so that the two systems can work cooperatively.

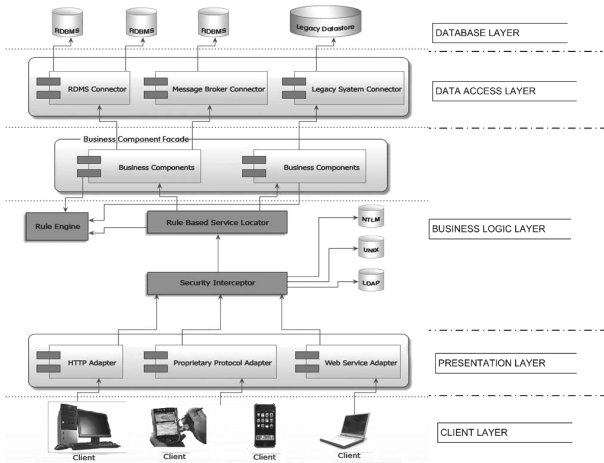

Fig. 3. J2EE application client and server architecture.

The JVM and Server side web components are used in Servlets and Java Server Page (JSP). As picture 3 shows an application client runs on a client machine and provides a way for users to handle tasks that require a richer user interface than can be provided by a markup language. It typically has a graphical user interface (GUI) created from the Swing or the Abstract Window Toolkit (AWT) API. Application clients directly access enterprise beans running in the business tier. However, if an application requirement permits it, an application client can open an HTTP

connection to establish communication with a servlet running in the web tier. Application clients written in languages other than Java can interact after enabling the Java platform to interoperate with legacy systems, clients, and non-Java languages.

As stated earlier to build fully functional personalized healthcare information system in ubiquitous environment, this system is divided into three sub modules. First one is personal healthcare module which is used to record and access several measurements, previous health status of patient etc, Second module is LiveGraph and oscilloscope which are incorporated with personal healthcare module. Both are developed to handle all information processing and creating diagnosis reports. There is another module which is also used for monitoring ECG and accelerometer data and the last and the main basic user interface which provide all these application to different user is MedRec which is the core GUI to interact with all other application.

A. Personal Healthcare module

Figure 4 illustrate the personal healthcare GUI which is developed with Java and swing. It consist of various module such as record various healthcare data from sensor through base station. Another module is compare health status for different time period. Different user accessing personal healthcare module with the help of different sensor embedded in USN sensor mote can take measure through Oscilloscope (implement in personal healthcare module). After measurement we can see the current health status as well as past record too. We can also analyze the current health status and pervious health status with personal healthcare module and without the help of any other body like physician. Old health data is stored in database which accessible anywhere through web application.

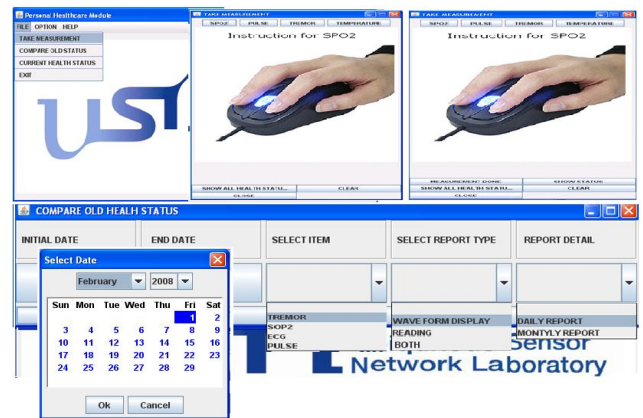

Fig. 4. Personal healthcare module.

Whole application is developed and incorporated with Tinyos [15] which is design and develop by University of California, with joint research effort with Intel Research, Tinyos is an open-source embedded operating system designed for wireless sensor networks and real operating system. In Tinyos maximum component is build in NesC programming language and most of GUI is develop in Java to give platform independence to OS, Tinyos offers a component-based architecture and is able to operate within the severe memory constraints posted by sensor networks. The copy of Tinyos used in this thesis is version 1.1.15, released in December of 2007.

The ECG features are used to detect life-threatening arrhythmias, with an emphasis on the software for analyzing the P-wave, QRS complex, and T-wave in ECG signals at application after receiving data from base station which is attached to USN mote. In personal healthcare module several other measurement modules also added for spo2, tremor, and body temperature. To measure all these healthcare diagnosis we used some specific sensor.

I. For measurement of ECG we used MEK MM200 ECG module with the following specification

- with 2-Channel ECG Wave Form (5-Lead)
- Heart rate & waveform
- 15 arrhythmia classification and 2-channel
- ST- Level Detection impedance respiration wave form,

II. For accelerometer we used LIS3L06AL MEMS INERTIAL SENSOR: 3-axis - +/-2g/6g ultra-compact linear accelerometer with the following specification.

- 2.4V to 3.6V single supply operation
- $\pm 2g/\pm 6g$ user selectable full-scale
- 0.5mg resolution over 100hz bandwidth
- Embedded self test
- Output voltage, offset and sensitivity ratio metric to the supply voltage
- High shock survivability
- to be integrated to PCB to connect to sensor node

III. for temperature we are using STLM20 Ultra-low current 2.4V precision analog temperature sensor.

- $\pm 1.5^{\circ}\text{C}$ temperature accuracy at 25°C
- Ultra-low quiescent supply current: $8.0\mu\text{A}$ (max)
- Operating voltage range: 2.4V to 5.5.

All above sensor are embedded in our USN sensor mote. Figure 5 illustrate the block diagram USN sensor mote where all three different sensors can be connected and with the help of Tinyos we manage whole architecture. This is the finalized version of USN

sensor mote, which is developed in USN lab to integrate various sensors such as ECG, Accelerometer and temperature. This sensor mote is incorporated with base station which transfers the data into personal healthcare module.

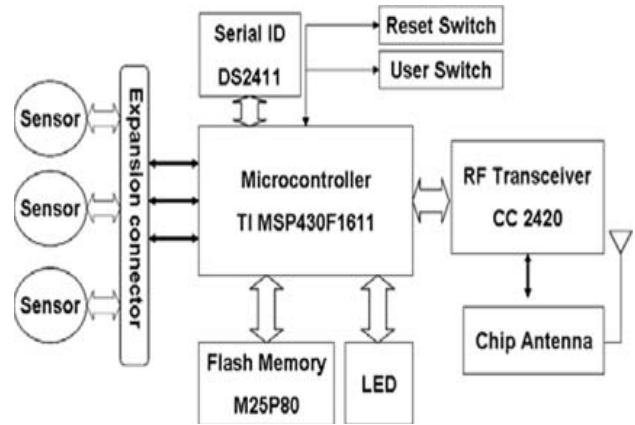

Fig. 5. Block diagram for USN sensor mote.

Personal healthcare module consist a modified oscilloscope program which process all the data into diagnosis message according to predefined algorithm. All sensor data is processed and executed on the application server with the help of LiveGraph. We can also analyze the data with previous record and if we want we can send all this processed data on database. Later this data can be accessible anywhere with the help of Personal Healthcare module through internet. But still we didn't consider that option but that can be future work to make this application Ubiquitous personal healthcare system. In this way we achieve the maximum utilization of resources such as physician etc. This data can also accessible at hospital or institute also after that processed with personal healthcare module.

B. LiveGraph and Oscilloscope

Another module is incorporated with personal healthcare module are LiveGraph and Oscilloscope.

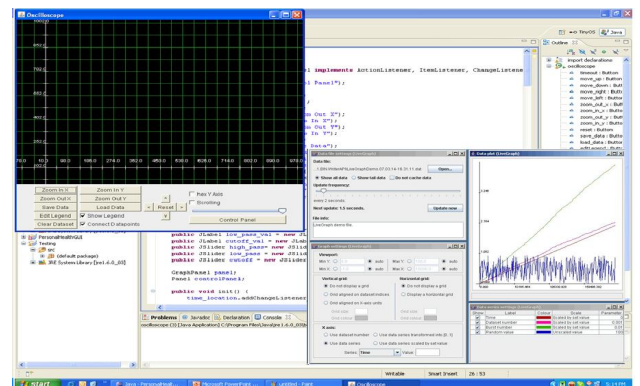

Fig. 6. Modified Oscilloscope and LiveGraph

Figure 6, illustrate the both applications which are incorporated with personal healthcare module. The basic goal of personal healthcare system here is to develop architecture to create, operate and evolve an enterprise-wide information system that meets the needs of its users, flexibly and cost effectively. To analyze healthcare data we have modified LiveGraph which is open source for exploratory data analysis and visualization framework. LiveGraph is a great tool for simulation of .CSV data format but after modification with LiveGraph we try to find a suitable analyzer for personal healthcare system, now it can process different kind of data such as .XLS, .TXT and .DB as well as .CSV style data format too.

Another module is incorporated with personal healthcare module is Oscilloscope. Oscilloscope is java based program developed by Tinyos [13] which is design and develop by University of California, with joint research effort with Intel Research. In personal healthcare system this Oscilloscope is modified accordance to specific requirement. LiveGraph system architecture consists of two parts first one is active parts and another one is communication channel between the two modules. The main GUI is LiveGraph plot module with a rich GUI and capable of plotting of plotting graphs based on data contained in a data stream in real-time.

C. MedRec Architecture

While developing personalized framework for personal healthcare system it needs a web application which can be accessed anywhere and which also provides a direct access to personal healthcare records as well as patient medical data. To achieve this requirement we build MedRec [16] which plays a key role in whole personal healthcare system. It's developed in J2EE and XML which is the main Front for each user. Personal healthcare module, LiveGraph and Oscilloscope and another ECG and Accelerometer modules all are incorporated in it and can be used with the help of MedRec. Temporarily all the database is handled with MedRec Weblogic Server later that can be implemented with oracle or specific database.

The MedRec application suite consists of three separate applications for the patient, physician, and administrator user roles which shown in figure 7. Using a separate application for each user role allows distributing each application function across different Weblogic Server instances as needed. The MedRec domain (optionally installed with Weblogic Server) deploys all three applications on a single server instance for demonstration purposes.

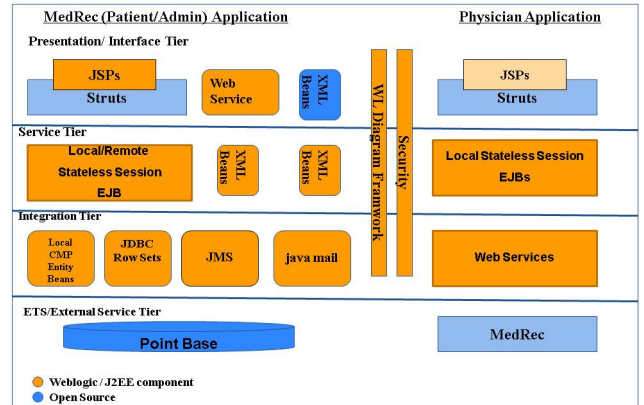

Fig. 7. MedRec core Architecture.

The MedRec also deploy the applications in a single-server domain, which is typical for development environments. The MedRec project directory also contains subdirectories for compiling the client applications that access MedRec via Web Services. MedRec includes a service tier of Enterprise Java Beans (EJBs) that work together to process requests from client applications in the presentation tier and from Web applications, and Web services workflow applications. The application includes message-driven, stateless session, stateful session, and entity EJBs. The MedRec physician web application should be housed in a different server/domain accessing the database managed by the patient and admin web apps on their own domain. In presentation layer MedRec apps uses Java Server Pages (JSPs) tags and Jakarta Struts 1.0 intelligence to populating Enterprise Java Beans that request Actions within the service tier.

IV. PERFORMANCE ANALYSIS

For the experimental setup a sensor board is integrated to a wireless sensor node which consists of an ECG and a tri-axial accelerometer sensor as shown in figure 5. In the sensor board, ECG signals from the electrodes are amplified with a gain of 300 (24.8 dB) and filtered with the cut-off frequencies of 0.05 Hz and 123 Hz. An ECG electrode has two electrodes which are integrated within the sensor belt. In addition, the sensor board also has a three-axis accelerometer sensor to measure acceleration signals.

These sensor nodes collectively monitor a ubiquitous area and generate a substantial amount of data and transmit that collected data from one node to another node via radio frequency signals and routing algorithms, as shown in figure 6. We have tested real time health data with this experimental setup. Sensor mote (attached with application) serves as base station between the patient mote and PC, receiving motes wireless packets. Base station is serially connected. This sensor mote can be use with base station which transfers the data into MedRec.

MedRec also consist a modified oscilloscope (which comes with Tinyos and develop in java) program which process all the data into diagnosis message. That information is processed and executed on the application server on LiveGraph.

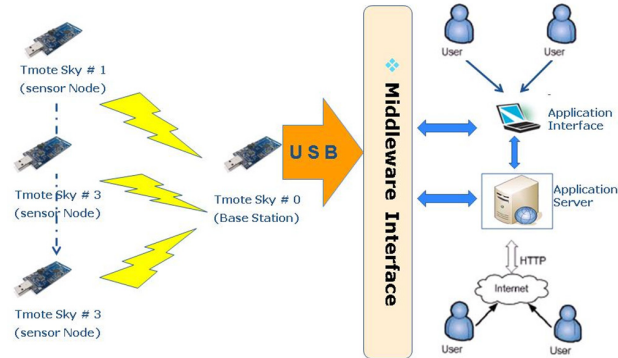

Fig. 8. Simulation architecture between sensor mote and application Interface

Simulation is an essential and complex part of any systems research and the hardest. Most time-consuming part of simulation phase is development of user interface, especially monitoring tools and visual display. Several visualization frameworks are available however they usually require extensive data preparation from the model developer and trade off powerful functions for a complex, slow-to-use user interface. Such frameworks are targeted at post-simulation data analysis.

In this paper main goal was to provide a capability for real time (software) analysis of data with activity monitoring at server. After detecting an abnormality by doctor by examining data on LiveGraph that data will transfer to server, which can be use later on by some specific user like himself, nurse and physician. If patient want then his data also can be used for research work. The services provided to client from server made possible by using healthcare middleware. Designing of data format is still in progress due to compatibility between healthcare data packet format like ECG packet format, Accelerometer packet format. We are using healthcare packet format [17] provided in table 1 and table 2 and having experiment with middleware suitability.

TABLE I
ECG PACKET FORMAT

Head Data Part (5 bytes)				Payload Data part (26 bytes)			
Message address	Active Message handler	Group ID	Message Length	Mote Id	Count	ADC Chanel	Data
2 byte	1 byte	1 byte	1 byte	2 byte	2 byte	2 byte	20 byte

TABLE II
ACCELEROMETER DATA FORMAT

Address	AM type	Group ID	Data Length
2 byte	1 byte	1 byte	1 byte
TOS Header			
Node ID	Last Sample Number	Channel	Data
2 byte	2 byte	2 byte	20 byte

A. Analysis Tool

There are various systems available for comprehensive data analysis in a post-simulation (after collecting data from various sensor nodes at system/application) phase. GNUPlot is a very powerful plotter system featuring its own scripting language. Computer algebra and numerical computation packages such as Mathematica, Maple or Matlab also often offer advanced plotting facilities along with powerful statistical and mathematical tools.

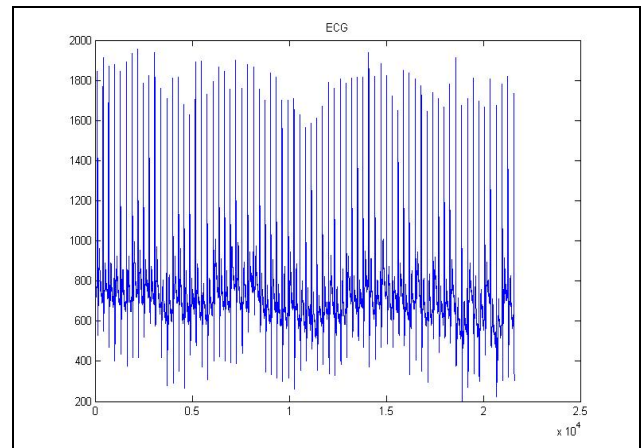

Fig. 9. ECG data analysis with MATLAB.

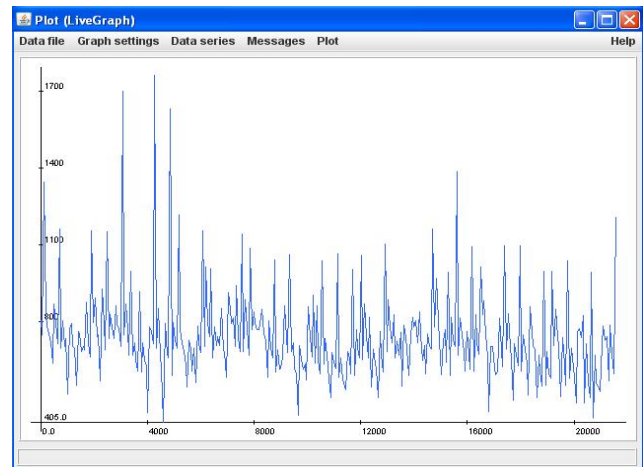

Fig. 10. ECG data analysis with live graph.

All these systems are very powerful, but they usually require a lot of effort in data preparation and trade off a lot of advanced features for a slow-to-use user interface. But none of them provide the open source to integrate their tool into your application, as well as none of them are flexible to use with any programming language. After developing LiveGraph into personal healthcare system it can be used as independent analysis tool for many kinds of data. It will not only analyze the CSV data format but now it can also maintain different kind of data format such as .XLS, .TXT, .DB etc.

Figure 9 shows ECG data in wave form with little bit noise. Figure 10 shows the same data after noise filtrations in better wave form in LiveGraph. After analysis both wave graphs it's an easy to decide that LiveGraph is good enough to use as an analysis tool in personal healthcare module. Even if we want still we can't use MATLAB in any application. But still LiveGraph fulfills most of the requirements which any user needs for basic healthcare application. After adding another support for different data formats it's a better option for analysis in any web application. There are several features that can be added like after ECG analysis, there can be some instructions that can also be added which can be accessible for users anywhere by using web applications.

With the help of these analysis tools different users can utilize this application in different ways. A physician can use LiveGraph to take some decisions after analysis of patient data. With the help of MedRec a user can access his/her data anywhere with the help of internet. He can feed his current data and also take live instructions with the help of MedRec a web application. If a patient needs he can also take fresh measurements with Personal Healthcare module which is inbuilt with LiveGraph and MedRec. In previous applications they only focus on communication of data from one node to another, their power consumption but none of them were meant to provide a simple and interactive user interface so a simple user can access his personal data and also take measurements by themselves.

V. CONCLUSIONS

In this paper a personalized healthcare information system in ubiquitous environment is proposed and implemented which is a flexible and fully functional system for patient monitoring at home or anywhere he can access the application. In this regard, several personalized and healthcare applications and home care solutions have been proposed, and implemented with the help of available information and communication technologies. However, according to our knowledge, development of personalized healthcare systems with consideration of specifically to GUI, communication and which also provide an analysis tool in a wholesome package, has not yet been investigated.

The key issue in personal healthcare system in ubiquitous environment is accessing their particular modules anytime anywhere. By applying Weblogic server we tried to get the real ubiquitous application as well as try to achieve the optimal treatment and support to users. One of the advantages of this system is it can deal with multiple user interfaces for different users. In personal healthcare system by applying middleware as a middle tier author tried to develop a common interface between several applications and user interfaces which can ease the interaction between users and applications.

In Personal Healthcare System there are several fields where a lot of research has to be done and is still going on and in future there is an endless scope to do work in personal healthcare too. In this paper we just show the base how we can build a smart application with the help of some available open source tools and after modifying them we can use according to personal healthcare requirements. This is just the beginning of Personal Healthcare information system, because in this paper our motive was only to display some patient healthcare data with different data and also provide an analysis tool to analyze their data.

ACKNOWLEDGMENT

This research was supported by Basic Science Research Program through the National Research Foundation of Korea (NRF) funded by The Ministry of Education, Science and Technology (2010).

REFERENCES

- [1] LiveGraph is a framework for real-time data visualization, analysis and logging <http://www.live-graph.org/index.html>.
- [2] Dipak Kalra, Thomas Beale, Sam Heard, The openEHR Foundation, Regional Health Economics and ICT Services: The PICNIC Experience, USA 2005
- [3] Osheroff JA, Pifer EA, Teich JM, Improving outcomes with clinical decision support: an implementer's guide. Chicago: Health Information Management and Systems Society; 2005.
- [4] Robert H Dolin, Liora Alschuler, Calvin Beebe, Paul V Biron, Sandra Lee Boyer, Daniel Essin, Elliot Kimber, Tom Lincoln, John E Mattison, "The HL7 Clinical Document Architecture", the Journal of JAMIA vol.8, issue6, nov/dec 2001,
- [5] Richard Leete, Ann Pawliczko, Madeleine Sacco "Report of an expert group meeting population aging and development: social, health and gender issues with a focus on the poor in old age", Oct 29-31, Valletta, Malta.
- [6] Aekyung Moon, Hyongsun Kim, Hyun Kim, and Soowon Lee (2007), "Context-Aware Active Services in Ubiquitous Computing Environments," ETRI Journal, Volume 29, Number 2, April 2007. pp. 169-178.
- [7] Heinzelman, W.B. Murphy, A.L. Carvalho, H.S. Perillo, M.A (2004), "Middleware to support sensor network applications", IEEE Network," Jan-Feb 2004. NY, USA;
- [8] Liu Fagui; Han Liu; Lin Kai; Ruan Yongxiong;" (2008) OSGi-based Reconfigurable RFID Middleware", paper presented at 2nd International Conference on Anti-counterfeiting, Security and Identification, 2008.
- [9] Angin, O.; Campbell, A.T.; Kounavis, M.E.; Liao, R.R.-F.; "The mobiware toolkit: programmable support for adaptive mobile

- networking." Journal of IEEE Personal Communications, August 1998. Pp 32- 43.
- [10] Murphy, A., Picco, G., and Roman, G.C.,(2001) "LIME: A Middleware for Physical and Logical Mobility. 21st International Conference on Distributed Computing Systems ICDCS, 2001.
- [11] Lo B., Thiemjarus S., King R., Yang G.Z., "Body sensor network—a wireless sensor platform for pervasive healthcare monitoring", in Proceedings of the 3rd international conference on pervasive computing, pp 77–80
- [12] Edward Curry, Paul Grace,(2008) "Flexible Self-Management Using the Model-View-Controller Pattern," IEEE Software, vol. 25, no. may-June 2008 3, pp. 84-90.
- [13] E.N. Hemess, Jr. R.J. High, and J.R. McGee, "WebSphere Application Server: A foundation for on demand computing", in the IBM Systems Journal, 2004, pp. 213-237.
- [14] Heqing Guan, Beihong Jin, Jun Wei, Wei Xu and Ningjiang Chen, "A framework for application server based Web services management", in the proceeding of 12th Asia-Pacific Software Engineering Conference, 2005. APSEC '05. march 2006. pp. 8.
- [15] TinyOS is an open-source operating system designed for wireless embedded sensor networks, available at <http://www.tinyos.net/tinyos-2.x/apps/Oscilloscope>.
- [16] Mangal Sain, Hoon Jae Lee, Wan-Young Chung, "Middleware in Ubiquitous Computing System with MedRec Architecture" in proceeding of the 2nd International Conference on Interaction Sciences : Information Technology, Culture and Human., Nov-24-26, Seoul, South Korea.
- [17] Moody, G.B.: WFDB Applications Guide, Harvard-MIT Division of Health Sciences and Technology (2004), <http://www.physionet.org> (retrieved April 25, 2004)



Mangal Sain received the Master of Computer Application (May 2003) from M.M.I.C.T & B. M. Mullana, under Kurukshetra University, Haryana, INDIA. At present, he is pursuing his Ph.D. degree in Ubiquitous IT at Ubiquitous Sensor Network Laboratory, Graduate School of Design & IT, Dongseo University, Busan - SOUTH KOREA. His current research interest includes developing middleware for Ubiquitous healthcare and other areas of interest are Ubiquitous Sensor Network, Secure Wireless Communication & Computing, Network and Information processing.



Wan-Young Chung Received B.S. and M.S. degrees in Electronic Engineering from Kyungpook National University, Daegu, Korea in 1987 and 1989 respectively and Ph.D. degree in Sensor Engineering from Kyushu University, Fukuoka, Japan in 1998. From 1999 to 2008, he was an associate professor in Dongseo University. Since 2008, he has been a professor in the Department of Electronic Engineering, Pukyong National University. The areas of interest include Ubiquitous Healthcare, Wireless sensor Network and Embedded Systems.



Hoon-Jae Lee received his BS, MS, and PhD degrees in electronic engineering from Kyungpook National University, Daegu, Korea in 1985, 1987, and 1998, respectively. He is currently an associate professor in the School of Computer & Information Engineering at Dongseo University. From 1987 to till date, he was a research associate at the Agency for Defense Development (ADD). He has more than 150 national/international technical publications as well as about 50 patents. His current research interests include developing secure communication system, secure Wireless Sensor Network, and Side-Channel Attack.