

# Research and Development of RFIC Technology in Smart Temperature Information Material

Chih-Yuan Chang<sup>1</sup>, San-Shan Hung<sup>2</sup>, Yu-Chueh Chang<sup>3</sup>, and Yu-Fang Peng<sup>4</sup>

**Abstract:** Conservation of energy and fuel is the trend in smart building design. Radio Frequency Integrated Circuit (RFIC) technology is often used in temperature sensing and signal transmission to manage indoor temperature, but it is rarely applied to the shell of the building. Heat retention and poor insulation in building shells are the largest causes of high energy consumption by indoor air conditioning. Through combining RFIC technology with temperature sensors, this study will develop smart temperature information material that can be embedded in concrete. In addition to accurately evaluating the effectiveness of shell insulation material, the already-designed Building Physiology Information System can monitor long-term temperature changes, leading to smarter building health management.

**Keywords:** Radio Frequency Integrated Circuit (RFIC); smart building; insulation; energy conservation; sustainability.

## I. INTRODUCTION

In Taiwan, most buildings are of reinforced concrete (RC) structures, which take 77.6% of the total amount of buildings [1]. Due to the heat retention quality of concrete, building envelope stores a large amount of heat in the day. Since the location of Taiwan crosses the sub-tropical and tropical zone, its weather is hot and humid. Solar insolation in the summer is extremely high. Also, inefficient thermal insulation of the building shells escalates the power consumption of indoor air-conditioning. The cooling capacity calculation shows that the heat of solar radiation entered through walls and windows take more than 30 % of the cooling capacity [2]. To keep the indoor environment comfortable, a mechanical air-conditioning system needs a significant amount of energy, causing high energy cost [3]. Therefore, the insulation efficiency of the building shells not only affects the indoor thermal environment and comfortableness directly, but also results in increases in energy consumption and cost.

In terms of the amount of energy consumption, buildings rank the third, surpassed by industrial production and transportation. However, because the service lives of buildings are far longer than industrial products, benefits of energy conservation on buildings are more significant in the long run. As a result, strategies for energy conservation of buildings are more important than energy conservation plans of other industries [4]. To cut down energy consumption of buildings, energy conservation on building shells plays an important role. In the day, solar radiation

energy is absorbed and retained in building shells and released into the indoor space. Therefore, improving thermal properties of the building shells is a key strategy for energy conservation of the buildings [5]. Insulation performance of the building shells is the main factor affecting the efficiency of building energy conservation. An insulation layer with good thermal properties can reduce the amount of heat passing through building shells, which is influenced by the properties of building shell materials and the climate [6]. Al-Ajlan SA also agreed that using thermal insulation materials is one of the most effective strategies for building energy conservation [7]. If no thermal insulation treatment is made on a building structure, a certain amount of heat will be accumulated in the structure after a period of exposure to the sun, making its indoor environment uncomfortable for its occupants. Hence, thermal insulation in buildings is the foremost measure for providing a comfortable indoor environment [8]. All in all, the issues of thermal insulation materials for building shells and building energy conservation are very crucial. Likewise, the related research subjects, such as the selection of insulation materials and evaluation of their insulation performance, are essential. Most buildings in Taiwan are of RC structures. For insulation treatment of the building roofs, PS-layer insulation tiles, plants, varnished corrugated sheets, thermal insulation paint are often used to block the solar radiation heat from transmitting into the indoor space in order to cut down the energy consumption of air-conditioning and improve the comfortableness of indoor environments.

<sup>1</sup> Assistant Professor, Dept. of Civil Engineering, Feng Chia University, No. 100, Wenhwa Rd., Seatwen, Taichung, Taiwan 40724, R.O.C., rchang@fcu.edu.tw (\*Corresponding Author)

<sup>2</sup> Associate Professor and Chairman, Dept. of Automatic Control Engineering, Feng Chia University, No. 100, Wenhwa Rd., Seatwen, Taichung, Taiwan 40724, R.O.C. sshung@fcu.edu.tw

<sup>3</sup> Graduate Student, Graduate Institute of Civil Engineering, Feng Chia University, No. 100, Wenhwa Rd., Seatwen, Taichung, Taiwan 40724, R.O.C., eddataco@hotmail.com

<sup>4</sup> Master, Graduate Institute of Civil Engineering, Feng Chia University, No.22, Xingzhu St., East Dist., Hsinchu, Taiwan 30061, R.O.C., mma3385@yahoo.com.tw

At present, most studies analyse thermal insulation performance of the building shells by way of indirect measurement, such as using simulation software or calculating thermal conductivity coefficients of the materials. The results of these studies are very helpful to the design and planning of buildings. Nonetheless, if a sensor device is developed to monitor the thermal variations inside RC structures continuously for a long period of time at the operation stage of the buildings, the results of the direct measurement and analyses will provide architects a more concrete reference resource when choosing the insulation materials and evaluating the insulation performance of each material at a building's design stage. For this purpose, this study develops a Smart Temperature Information Material (STIM) via electronic circuit design. A STIM combines a Radio Frequency Integrated Circuit (RFIC) with a temperature sensor chip and adopts encapsulation boxes to protect the device from possible damages. The dimension of the STIM is 50mm\*48mm\*50mm (length\*width\*height), which can be buried into a RC structure to monitor the continuous changes of temperature inside the structure. As to the design of the user interface, this study uses Borland C++ Builder to develop a Building Physiology Information System (BPIS.) The design of BPIS includes a database and the human-machine interface. In addition to monitoring a RC structure in real time, long-term temperature measurement values at all sensor points are also recorded. The design is useful for analyses of insulation performance of insulation materials and evaluation of the benefits of energy conservation. The results can be consulted by architects and building managers when choosing building materials or analysing the energy use of air-conditioning.

## II. THE APPLICATION OF RFIC AND RFID TO SMART BUILDINGS

### A. The Application of RF Technology to Smart Buildings

With the arrival of high-tech information age, the way of living is changing. In the field of architecture, e-planning of the interior environment has become a new trend. How to make our life safer, healthier, more comfortable, and more convenient, more energy efficient, and more environments friendly has become the focus of our home environment design.

Recently, Radio Frequency (RF) technologies have developed rapidly. Among them, the application devices of Radio Frequency Identification (RFID) and Radio Frequency Integrated Circuit (RFIC) are the most noticeable. There are many application products of these two technologies on the market. Because the transmission techniques of these two technologies are different, the areas of their applications are also varied. Applications of the RFID technology are widely seen in smart living space. The wireless identification technology can be used in various areas, including access cards, transportation passes, library management systems, building management, logistics

management, chip locks for vehicles, animal management, and inventory control of drugs and equipments. Many studies were conducted for its application, such as applying RFID technology to study sensor-perception models in smart living environments [9]; applying RFID technology to the planning of the open building concept [10]; storing historical data with RFID to improve the efficiency of building maintenance [11]; applying RFID for tool tracking on construction job sites and improving the efficiency in construction [12]. Applications of RFID to smart buildings mostly make use of its identification function to track, locate and manage a target. In comparison, RFIC has a feature RFID does not have. Design software of objective function can be embedded in RFIC. After integrating with various kinds of sensor chips, information is received with the use of RF wireless technology and hardware design of receivers. The information received is processed and displayed based on the user's design. RFIC can be applied to a wide range of uses. For example, Andre N et al. used RFIC to monitor real-time breath activity [13]. In addition, RFIC integrated with temperature sensor chips can be used to measure indoor temperature changes when it is on air.

In 2004, Taiwan started promoting Intelligent Building Certification. The certification requirements and construction standards include Information and Communication, Safety and Hazard Prevention, Health and Comfortableness, Energy Conservation of Facilities, Generic Cabling, Integration of Systems and Facility Management [14]. A STIM and BPIS are useful to the design and planning of Energy Conservation of Facilities and Integration of Systems. Based on the RF technology, a STIM measures and monitors the inner temperature of building shells for the long run. BPIS incorporates the already existed Building Management System and serves as one of the dynamic monitoring and management modules. BPIS displays the signals transmitted by STIMs in real-time, and gives warnings when the inner temperature of building shells is too high or too low. In the future, it can also help building managers determine whether to replace thermal insulation materials or to activate the building shell cooling system for lowering the indoor temperature, reducing the frequency of air-conditioning use, and maintaining a healthy and comfortable indoor environment.

### B. Comparison between RFIC and RFID Technologies

RFID technology transmits identified data via radio waves. A RFID system consists of three parts: tags, readers, and information processing ends. After the coded data saved inside a tag, and the tag is read by the reader. Then, the read data is sent to the reader's built-in database and is queried and identified. The coded data of tags or the reader's query database are built-in data, which cannot be updated in real-time or execute other commands. Data identification is their main function. In contrast, the data is transmitted by RFIC by sending and receiving radio waves. Furthermore, design software of specific purpose and

sensor chips of different types can be integrated with RFIC. The values of physical quantities measured are sent to an assigned receiver via RFIC to be read or to give instructions. Besides transmitting data via wireless for the purpose of identification, RFIC can also work as a real-time monitoring system by setting data transmission times with micro-controllers. The transmission range and application fields of RFID and RFIC are also different.

Applications of the RFID extend its identification function to the management and tracking purposes. On the other hand, RFIC can be incorporated with other measurement systems for different purposes. The reception range of RFIC can be as far as a few hundred meters. Compared to RFIC, the reception range of RFID is shorter.

*C. Applying RFICwith Temperature/ Humidity Sensor Chips to Exterior Walls*

The monitor points required for exterior walls are numerous. In order to decrease the number of receivers used (due to the cost concern), the transmission range should be longer. The pilot research result of this study shows that when a RFIC transmitter is embedded in a RC concrete specimen of the 30 cm thickness, the signal transmission range of the RFIC transmitter is as far as 7.3 meters, and the signal can penetrate two concrete floor slabs [15]. For example, a RFIC receiver placed on 2F can receive signals transmitted by RFIC transmitters embedded in the RC exterior walls or RC floor slabs on 1F and 3F.(STIM referred in this paper is a RFIC transmitter with sealing treatment, put in an encapsulation box.) In short, the study embeds a STIM into structures of the exterior walls, and transmits temperature and humidity data measured inside the structures to a RFIC receiver via RF technologies. Then, the data is sent to BPIS through RS-485 to monitor the changes in inner temperature and humidity of buildings. Furthermore, this system also allows remote monitoring. See Figure 1 for the illustration of STIM.

FIGURE 1  
APPLYING STIMSTO REMOTE MONITORING OF EXTERIOR WALLS

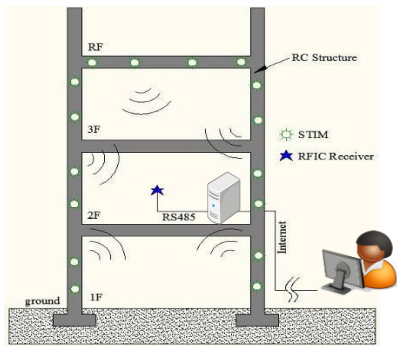

III. DEVELOPMENT OF THE STIM

A. RFIC Transmitter and Receiver

A STIM is a sealed RFIC transmitter device, which is placed into a shock-proof encapsulation box. The encapsulation box allows enough measurement space for the RFIC transmitter. During its development process, a few issues must be addressed, such as how a STIM may affect a building’s structural strength, installation convenience, and shock resistance demands for its installation in construction sites. STIMs should be as small as possible. Therefore, after several modifications, the dimension of RFIC transmitter is 40mm\*28mm\*30mm (length\*width\*height (the antenna is included)) See Figure 2.

FIGURE 2  
RFIC TRANSMITTER



Many problems were encountered during the development process of the STIM. For instance, RFIC transmitters cannot come in direct contact with the concrete. Also, moisture inside the concrete may rust and damage the chips. As a result, it is necessary to design a suitable sealing treatment to block air and moisture, and prevent the possible damages to RFIC transmitters caused by the concrete. The design of encapsulation boxes is another important issue.

FIGURE 3  
WORK PROCESS AT THE RF SENDING END

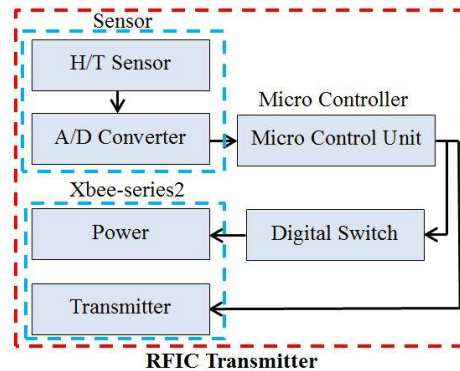
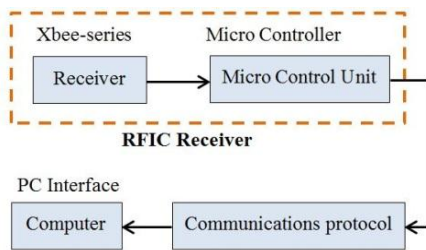

FIGURE 4  
WORK PROCESS AT RF RECEIVING END



The design of data transmission and reception can be divided into the sending end and receiving end. Some of the sensors at the sending end are H/T sensors. Temperature and humidity are measured by the sensors. Generally, output signals are analog signals. However, a micro control unit (MCU) can only process digital signals; therefore the analog signals must be converted to digital signals. The conversion is made by A/D converters built inside the sensors. The converted digital signals are sent to the MCU for signal processing and encoding. The MCU can also control the digital switch and data transmission. The digital switch controls the power of Xbee. Data can only be transmitted from the sending end to the receiving end after the power is switched on. After data is received at the receiving end, it is sent to the MCU for signal processing. Then, the processed signals are transmitted to the computer via communication protocols and displayed on the user interface of BPIS in real-time. See Fig. 3 and Fig.4.

*B. Temperature and Humidity Sensors*

The main purpose of this study is to measure the dynamic changes of temperature inside a building structure. In order to broaden the scope of this study, the authors decided to choose a sensor which can measure both temperature and humidity. Based on the requirements of this study, the digital temperature and humidity sensor, SHT 1x/7x series, manufactured by S company was chosen. See Figure 5.

FIGURE 5  
H/T SENSOR

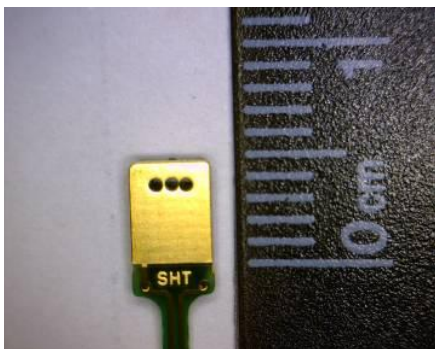

Figure 5 is a picture of the H/T sensor, enlarged by a digital microscope. The dimension of the sensor head on the top is 5mm\*4mm\*2mm (length\*width\*thickness). It has several advantages: small size, fast response, low power consumption, waterproof, high noise immunity, long-term stability, and measuring both temperature and humidity. Furthermore, all H/T sensors are fully calibrated before they are sold on the market. The sensors' chips are of high precision. See Table 1 for the precision and resolution of the H/T sensor.

TABLE I  
PRECISION AND RESOLUTION OF THE H/T SENSOR

	Temperature	Humidity
Precision	±0.4 °C	±3.0 %RH
Resolution	0.01 °C	0.03 %RH

*C. The Encapsulation Box*

In order to measure the temperature and relative humidity inside the structure of a RC structure, the RFIC transmitter must be buried into the concrete. Also, to allow for temperature and humidity measurement, a 3D space must be created, which is the primary function of the encapsulation box. Furthermore, concrete slump is strongly alkaline, and water content of concrete and the impact of concrete pouring would damage RFIC transmitters. Thus, the second goal of the encapsulation box design is to solve the problems of strong alkaline, high water content, and strong impact. As a result, the shock-proof capability of the box, its material choices, and the mix proportion of the covering cement mortar must be tested and modified several times. See Fig. 6 for the final model of the encapsulation box.

FIGURE 6  
SEALING TREATMENT AND THE ENCAPSULATION BOX

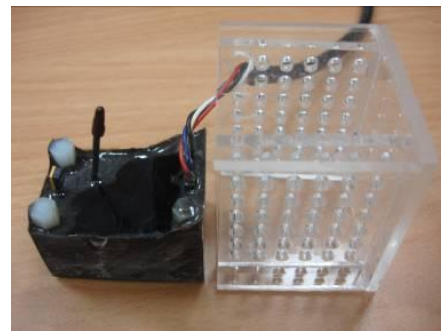

**IV. APPLYING BPIS TO EVALUATING THE THERMAL INSULATION PERFORMANCE OF THE THERMAL INSULATION MATERIALS AND SMART BUILDING ENVELOPE**

**A. Introduction to the BPIS**

In order to use memory space efficiently, Building Physiology Information System (BPIS) is developed with C++ language. A relational database is also designed for storing the received data of temperature and humidity, and building information related to the measurements.

**FIGURE 7**  
USER INTERFACE (BPIS)

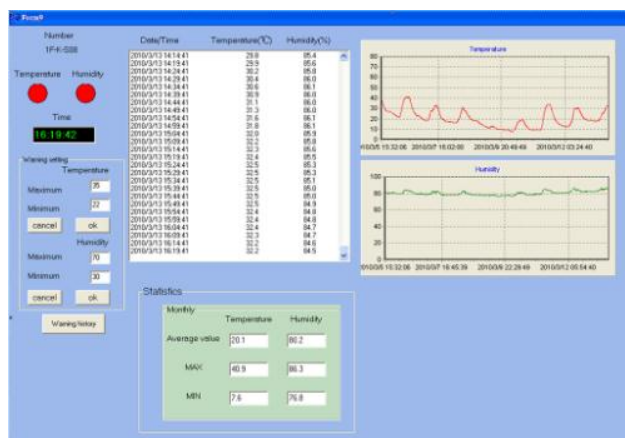

The values of temperature and humidity measured by the STIM are transmitted to a RFIC receiver through RF wireless transmission. Then, the receiver sends the data via RS-485 to real-time display on BPIS. The information displayed by BPIS includes: the changes in values and graphs; the setting of maximum and minimum values which trigger warnings; and status lights. See Figure 7 for a monitoring result at one single point.

**B. An Example of Measurement and Evaluation of Thermal Insulation Benefits**

The authors embedded a STIM into RC specimens which simulate roofing slabs. The control group is a RC slab without any thermal insulation material. The experimental group is a RC slab covered by insulation bricks commonly seen in Taiwan (see Figure 8 and Figure 9).

**FIGURE 8**

THE CONTROL GROUP IN THE EXPERIMENT OF INSULATION PERFORMANCE



**FIGURE 9**

THE EXPERIMENTAL GROUP IN THE EXPERIMENT OF INSULATION PERFORMANCE



The experiments were conducted in different weather conditions for comparison. In each weather condition (on a sunny day, on a cloudy day, and on a rainy day), one sample is selected. See Figure 10. On the rainy day, the insulation benefit of the experimental group is not very noticeable. In contrast, the benefit of insulation is best shown on the sunny day. The study then evaluated the sample on the cloudy day—the middle ground between the sunny day and the rainy day, and it is found that the maximum temperature difference of experimental group specimen was 3.5°C. Moreover, the heat absorption time was 8.3 hours, and the heat emission time was 10.3 hours. The heat absorption is faster than heat emission. The heat absorption rate is 1.24 times higher than the emission rate. The maximum temperature difference of control group specimen was 15°C. The heat absorption time was 8.8 hours, and the heat emission time was 13.5 hours. The heat absorption rate was 1.53 times higher than the emission rate. As the sample of cloudy day on Fig.9 shows, on that day, the maximum temperature difference of the experimental group and the control group could be as high as 12.7°C (43.4°C-30.7°C). The air-conditioning was turned on for 10 hours a day from 8:00 a.m. to 18:00 p.m. The

authors analyzed the average value of daily temperature differences and found that the experimental group, which was covered by the insulation bricks, on average could block 8.5 °C /per hour during the 10 hours of air-conditioning use. For an indoor space of 330 m<sup>2</sup>, the reduced energy consumption (electric power: 20.2 Kw) each day can be converted into a saving of electricity bill for 332 NTD (around 11 USD).

FIGURE 10  
TEMPERATURE MEASUREMENTS OF THE INSULATION MATERIAL

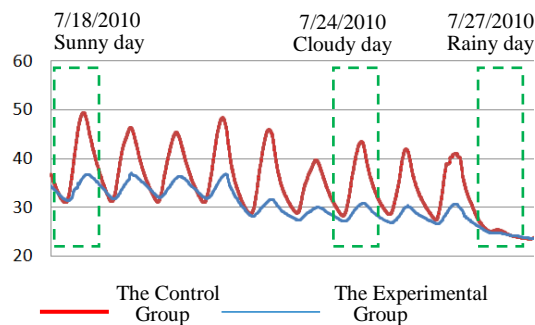

Finally, better thermal insulation performances of the insulation materials cannot be always translated into higher energy conservation benefits on the building shells since another factor-payback period-must be taken into account. Two factors are considered when calculating the payback period. One factor is the total input cost (CF<sub>0</sub>), which includes the total amount of construction and construction cost, service life, and the maintenance expense. The other factor is the yearly benefit (CF), such as the saved electricity expense due to the reduced air-conditioning use. Therefore, when building managers are evaluating the energy conservation benefits of the thermal insulation materials, they should consider the thermal insulation performance, the material cost, the service life, and the total maintenance cost of each insulation material.

## V. CONCLUSIONS

Thermal insulation performance of the thermal insulation materials are generally evaluated based on their thermal conductivity coefficients. The approach overlooks that a building structure is not of homogeneous materials (including concrete, steel bars, pipes or gaskets) and the installation quality of the thermal insulation materials is not consistent, which results in the imprecise evaluation of insulation performance. This study is a cross-disciplinary study, which incorporates expertise from the field of automatic control. The STIM is designed by integrating RFIC technology with temperature sensors. Then, the STIM is embedded into RC structures, and data is transmitted via wireless transmission. Therefore, the device is not restricted by landforms and roof structures and also allows building

managers monitor the dynamic temperature changes on the user's interface of BPIS system remotely. When ACE/FM or on-site building managers evaluate the benefits of energy conservation, they can also consult the long-term data of dynamic temperature changes as the basis for analyzing the thermal insulation performance of thermal insulation materials.

## ACKNOWLEDGEMENTS

The research team acknowledges with gratitude the 2010 research grant issued by National Science Council (Project no: NSC 99-2221-E-035-076)

## REFERENCES

- [1] C.Y. Chang, W.H. Hsiao, S.M. Huang, S.J. Guo, "Supply and Demand for Building Health Check", *Journal of Architecture*, no. 59, pp. 93-112, March 2007.
- [2] D.C. Chou, J.J. Chiou, "A Study on the Insulation Performance of a Double Skin Roof Induced by Natural Ventilation", *Journal of Architecture*, no. 59, pp. 79-92, March 2007.
- [3] J.L. Alvarado, W. Terrell Jr., M.D. Johnson, "Passive cooling systems for cement-based roofs", *Building and Environment*, vol. 44, no. 9, pp. 1869-1875, September 2009.
- [4] H.T. Lin, "Energy efficiency design of building envelopes and Strategies for reducing CO<sub>2</sub> emission", Architecture and Building Research Institute, Ministry of the Interior, 2007.
- [5] X. Wang, Y.P. Zhang, W. Xiao, R.L. Zeng, Q.L. Zhang, H.F. Di, "Review on thermal performance of phase change energy storage building envelope", *Chinese Science Bulletin*, vol. 54, no. 6, pp. 920-928, 2009.
- [6] A. Praditsmanont, S. Chungpaibulpatana, "Performance analysis of the building envelope: A case study of the Main Hall, Shinawatra University", *Energy and Buildings*, vol. 40, no. 9, pp. 1737-1746, 2008.
- [7] S.A. Al-Ajlan, "Measurements of thermal properties of insulation materials by using transient plane source technique", *Applied Thermal Engineering*, vol. 26, no. 17-18, pp. 2184-2191, December 2006.
- [8] H.Y. Huang, "Study of Insulation Performance Using Multi-layer Material on Roof", Architecture and urban design Institute, Master thesis, Taipei University of Technology, 2009.
- [9] M.L. Chiu, "Applying RFID Technologies to Study Sensor-Perception models in Smart Living Environments - Smart Houses as examples", National Science Council, 2007.
- [10] M.Y. Cheng, "RFID applications of Building Life Cycle", Architecture and Building Research Institute, Ministry of the Interior, 2008.
- [11] E. Ergen, B. Akinci, R. Sacks, "Life-cycle data management of engineered-to-order components using radio frequency identification", *Advanced Engineering Informatics*, vol. 21, no. 4, pp. 356-366, October 2007.
- [12] P.M. Goodrum, M.A. McLaren, A. Durfee, "The application of active radio frequency identification technology for tool tracking on construction job sites", *Automation in Construction*, vol. 15, no. 3, pp. 292-302, May 2006.
- [13] N. Andre, S. Druart, P. Gerard, R. Pampin, L. Moreno-Hagelsieb, T. Kezai, L.A. Francis, D. Flandre, J.P. Raskin, "Miniaturized Wireless Sensing System for Real-Time Breath Activity Recording", *IEEE Sensor Journal*, vol. 10, no. 1, pp. 178-184, January 2010.
- [14] Architecture and Building Research Institute, Intelligent Building Standard, Ministry of the Interior, <http://iblogo.tabc.org.tw/ibsm/p-1-1.aspx>, (11/15/2010).

- [15] W.T. Chang, "The Development of Building Physiology Information System-Monitoring in Temperature and Humidity", Master thesis, Dept. of Civil Engineering, Feng Chia University, 2009.