

저궤도 위성의 전력 시스템 안정화를 위한 모델링 및 제어

윤석택*, 원영진*, 이진호* 정회원

Stabilization Converter Design and Modeling of LEO Satellite Power Systems

Seok-Teak Yun*, Young-Jin Won*, Jin-Ho Lee* *Regular Members*

요 약

위성 산업은 상업적 군사적 유용성 등의 특성으로 인해 지속적인 발달이 이루어져 왔다. 이 중에서도 위성의 전력 시스템은 위성의 수명에 직접적인 관련을 가지고 있으며, 실제 궤도상에서의 Test가 불가능한 특성을 보인다. 또한 저궤도 소형위성은 전력에 민감하므로, 효과적인 전력의 안정화 및 신뢰성 향상은 중요한 문제이다. 일반적으로 저궤도 위성의 전력은 각 부하의 특성에 따라 변환 및 제어가 이루어진다. 따라서 저궤도위성의 전력 시스템은 일반적으로 여러 단계의 전력 변환을 거치게 되므로, 신뢰성 향상을 위한 1차 및 2차 혹은 그 이상 단계의 Converter의 일반화 모델링 및 안정화를 위한 제어기 설계 및 외란에 의한 영향성의 분석이 요구된다. 본 논문에서는 저 궤도 위성 전력계 시스템의 전력 변환을 위한 Converter의 일반화 모델링을 통해 안정화 설계를 위한 파라미터를 추정하고 이를 통한 신뢰성 향상 및 최적 제어 방법에 대해 알아보기로 한다.

Key Words : LEO small satellite, power system, stabilization control, phase control, small signal modeling

ABSTRACT

Satellites industry has been developing with the commercial and military needs. Because power system of satellite is very important to survival operation and hard to test, increasing reliability is very critical. Due to LEO small satellites are very sensitive to power system, effective stabilization control is important. Therefore, this paper introduce methods for general modeling of power converting system which it can be used design of controller and analysis of external disturbance influences. In conclusion, a modeling of LEO small satellites power converting system and a possible guide line to design reliable controller which optimizing power converters of LEO small satellite are generated.

I. Introduction

The stabilization control of satellite power system is a major topic among research organizations because it is very important to survival operation and hard to test characteristics. In particular, demands for the development of compact power supplies with higher power density and higher efficiency have been increased. This paper introduces general modeling of converter system that can be applied to satellites to enhance stability and capability. Therefore the main discussion will be focused on a modeling technique and stabilization

design. Next, the paper will present a guide line to design reliable controller which optimizing power converters of LEO small satellite.

II. Modeling of LEO small satellite converter

Because of Load demand, several stage concepts are required for power distribution. Figure.1 shows the diagram of LEO small satellite electrical power distribution system. Once solar array generate power, first stage converter changes voltage and current for proper load condition. If first stage can't match all load condition, second stage power conversions are required.

*한국 항공우주연구원 다목적5호 체계팀 (yungun@kari.re.kr)

접수일자 : 2010년 8월 26일, 수정완료일자 : 2010년 9월 15일, 최종게재확정일자 : 2010년 10월 6일

1. The equivalent circuit and State equation of converter

Figure.2 shows the general converter model of LEO small satellite power system. VAB can be modeled by topology and disturbance and Bus specification. Other parameters present filter and parasite component. [1]

In order to analysis steady state and small signal, The EDF (Extended Describing Function) method is used for modeling of converter. A fundamental approach of EDF is useful for solve all state equation. The state equation of equivalent circuit is given by Equation (a) to Equation (h).

$$L_a \frac{di_{La}}{dt} = V_{AB} - V_{cd1} \quad (a)$$

$$L_p \frac{di_{Lp}}{dt} = V_{cd1} \quad (b)$$

$$L_m \frac{di_m}{dt} = V_{cd1} - V_{cm} - V_{cd2} - R_m \cdot i_m \quad (c)$$

$$C_{cd1} \frac{dV_{cd1}}{dt} = i_{Lp} - i_m - i_{Lr} \quad (d)$$

$$C_m \frac{dV_{cm}}{dt} = i_m \quad (e)$$

$$C_{cd2} \frac{dV_{cd2}}{dt} = i_m - \text{sgn}(V_{cd2}) \cdot i_{Lo} \quad (f)$$

$$L_o \frac{di_{Lo}}{dt} = |V_{cd2}| - (1 - \frac{r_o PR_L}{R_L}) \cdot V_{co} - (r_o PR_L) \cdot (i_{Lo} + i_o) \quad (g)$$

$$C_o \frac{dV_{Co}}{dt} = \frac{r_o PR_L}{r_o} (i_{Lo} - \frac{V_{Co}}{R_L} + i_o) \quad (h)$$

Additionally, the non-linear terms of above equations are three which is VAB, $\text{sgn}(V_{cd2})$, $|V_{cd2}|$. VAB can be modeled by fundamental switching frequency component. And, other terms symbolize effect of output rectified current which controlled by diode. Next, the equations can be approximated by fundamental frequency. The envelope terms have slow response than switching frequency. Therefore, differential Equation (i), (j) can

$$i(t) = i_s(t) \cdot \sin(\omega_s \cdot t) + i_c(t) \cdot \cos(\omega_s \cdot t) \quad (i)$$

$$v(t) = v_s(t) \cdot \sin(\omega_s \cdot t) + v_c(t) \cdot \cos(\omega_s \cdot t) \quad (j)$$

be denoted by Equation (k), (l)

$$\frac{di}{dt} = \left(\frac{di_s}{dt} - \omega_s \cdot i_c \right) \cdot \sin(\omega_s \cdot t) + \left(\frac{di_c}{dt} + \omega_s \cdot i_s \right) \cdot \cos(\omega_s \cdot t) \quad (k)$$

$$\frac{dv}{dt} = \left(\frac{dv_s}{dt} - \omega_s \cdot v_c \right) \cdot \sin(\omega_s \cdot t) + \left(\frac{dv_c}{dt} + \omega_s \cdot v_s \right) \cdot \cos(\omega_s \cdot t) \quad (l)$$

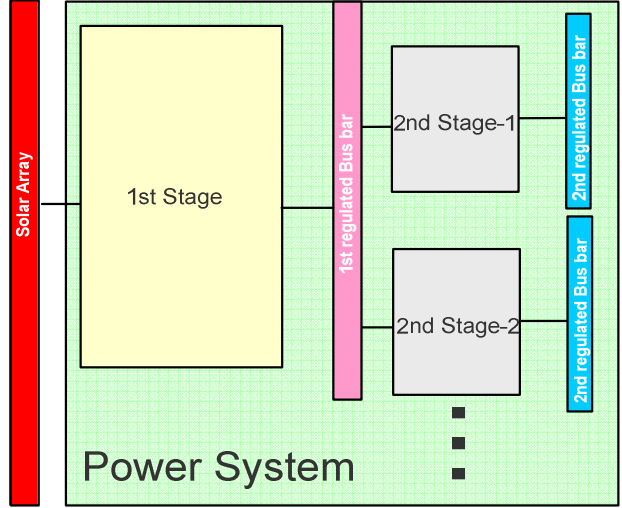

Figure 1. Diagram of LEO small satellite power distribution system

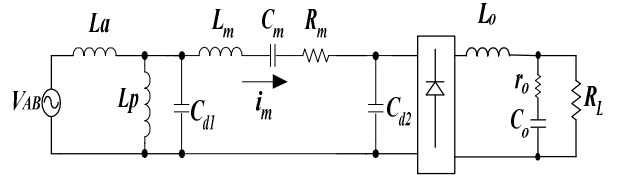

Figure 2. Equivalent circuit model of satellite converter

2. The Extended Describing Function approximation and modeling

The non-linear terms are approximated by blow equation by using Figure. 3. As shown figure 3, an asymmetry PWM topology is used for analyze.

A f1 function can solve by Fourier series. Since time constant is very slow, ILO also approximate DC component. Accordingly, because of $\text{sgn}(V_{cd2})$ ILO has same phase with Vcd2, f2,3,4 functions are justified by Equation (q),(r),(s). By substitute this equation, state differential equation divide by two. Thus terms are general equation of LEO small satellite converter.

$$V_{AB} \cong f_1(d, v_g) \cdot \sin(\omega_s t) \quad (m)$$

$$\text{sgn}(v_{cd2}) \cdot i_{Lo} \cong f_2(v_{cd2s}, v_{cd2c}, i_{Lo}) \cdot \sin(\omega_s \cdot t) + f_3(v_{cd2s}, v_{cd2c}, i_{Lo}) \cdot \cos(\omega_s \cdot t) \quad (n)$$

$$|v_{cd2}| \cong f_4(v_{cd2s}, v_{cd2c}) \quad (o)$$

$$f_1 = \frac{2}{\pi \cdot (1-D)} \cdot \sin(\pi \cdot D) \cdot v_g \quad (p)$$

$$f_2 = \frac{4}{\pi} \cdot \frac{v_{Cd2c}}{\sqrt{v_{C2s}^2 + v_{C2c}^2}} \cdot i_{Lo} \quad (q)$$

$$f_3 = \frac{4}{\pi} \cdot \frac{v_{Cd2c}}{\sqrt{v_{C2s}^2 + v_{C2c}^2}} \cdot i_{Lo} \quad (r)$$

$$f_4 = \frac{2}{\pi} \cdot \sqrt{v_{C2s}^2 + v_{C2c}^2} \quad (s)$$

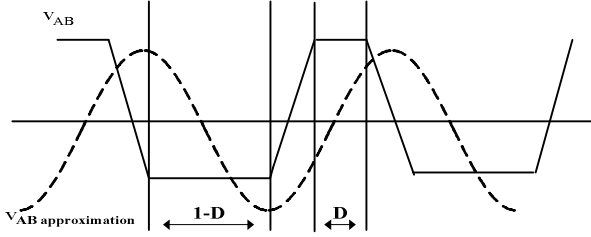

(a)VAB Approximation wave form

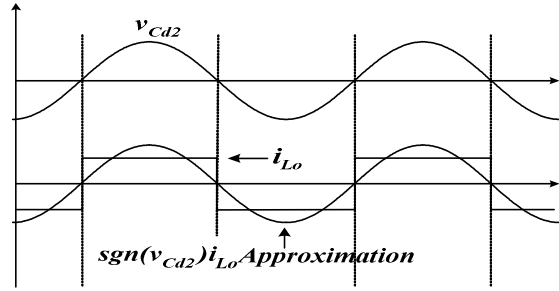

(b) sgm(Vcd2)ILO Approximation wave form

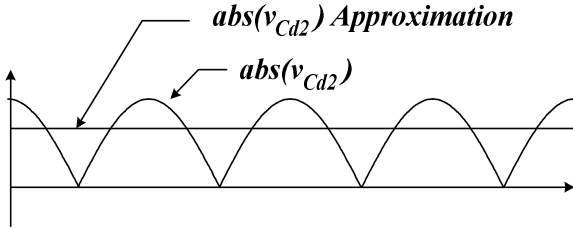

(c) abs(Vcd2) Approximation wave form

Figure 3. Approximation waveform for EDF modeling

3. Steady state solution and small signal modeling

In order to get steady state solution, differential components set to zero and solve the problem. The small signal model can be achieved by perturbation and linearization. To make two port models, value setting is needed. (See figure.4. input value: input voltage and output current. control value: duty and frequency. Output value: output voltage and input current or phase difference) [2], [3].

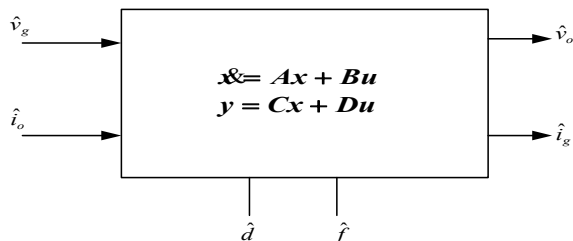

Figure 4. Two port small signal modeling

For example, if the difference between Vcd1 and ILM is needed, EDF modeling equation can be used. Figure 5 shows phase difference Vcd1 and ILM. This difference is given by Eq (t).

$$\theta = -\tan^{-1}\left(\frac{i_{Llc}}{i_{Lls}}\right) - \tan^{-1}\left(\frac{\left(\frac{D}{1-D} - \frac{D}{1-D} \cos\left(\frac{D}{T} 2\pi\right)\right)}{\left(\frac{D}{1-D} \left(\sin \frac{D}{T} 2\pi\right)\right)}\right) \quad (t)$$

$$= \theta_{fun} + \theta_0$$

This output value also small signal modeled by perturbation and linearization. In this paper, output voltage and phase will be stabilized by changing duty and switching frequency. [4]

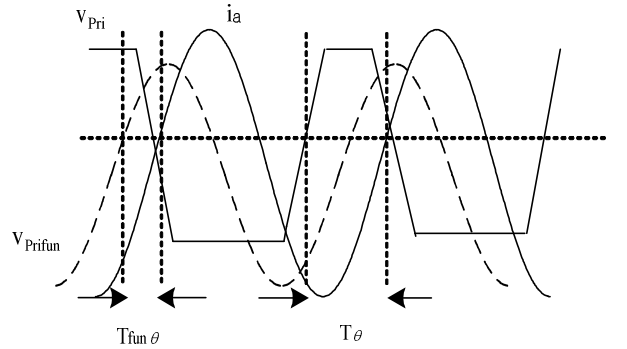

Figure 5. Phase difference wave form

III. Stabilization Control

In order to check stability in steady state condition, interaction of parameter is derived by general model. As shown in Figure 7, it checked that the selection parameter has no interference with others.

Next, the phase and voltage control of converter small signal concept is produced in Figure 6 as an example. By changing the duty and frequency out will be ratified. [5] Figure 6 shows the two port design block modeling of output voltage and phase control.

To compensator design, the inference analyzing of control loop between frequency and duty is derived in figure 7. As shown figure, the bandwidth of compensator is dominant for stabilization. Therefore, this paper designed that use 3-times higher control bandwidth as a duty loop then frequency loop. Final closed loop design result is shown in Figure 8, it has sufficient gain and phase margin with bandwidth difference between voltage and phase controller. Figure.9 shows the disturbance response at worst

steady state condition. it presents that the effect of disturbance is not amplified all frequency range.

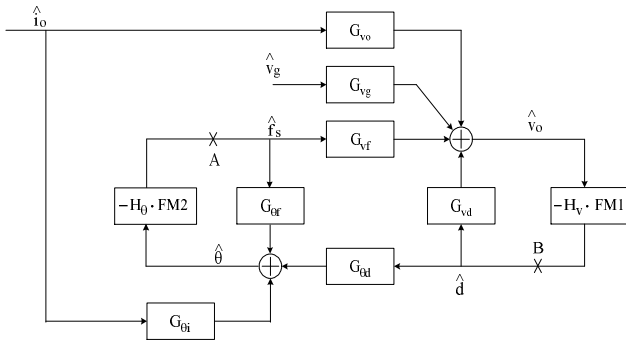

Figure 6. Small signal modeling diagram for phase and output voltage control

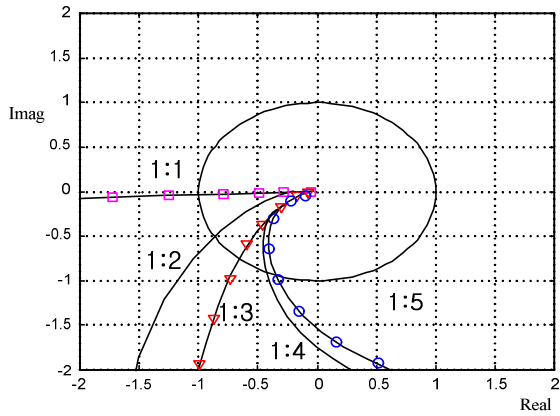
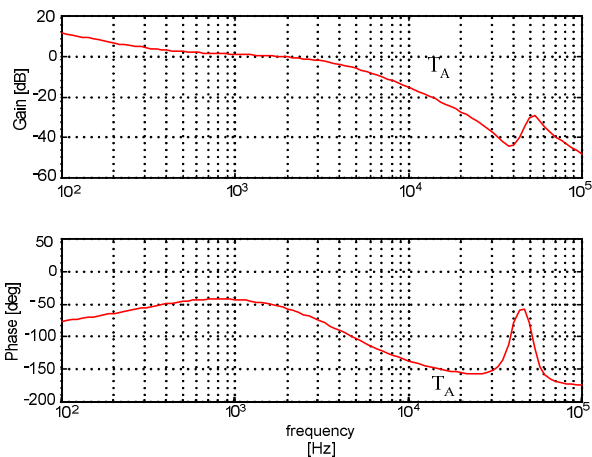
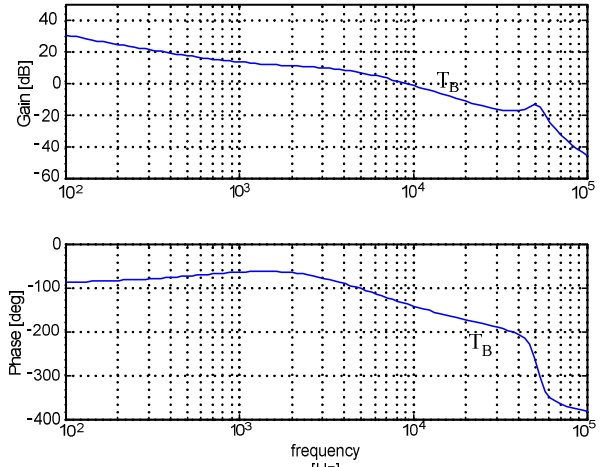

Figure 7. Bandwidth impact computation between duty and frequency control



(a) phase loop control design bode plot



(b) voltage loop control design bode plot

Figure 8. Open loop bode plot result each exclude compensator deassign

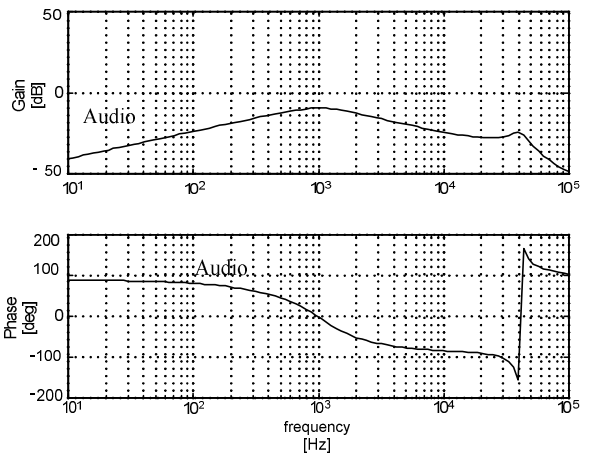

(a) Audio susceptibility response at worst case

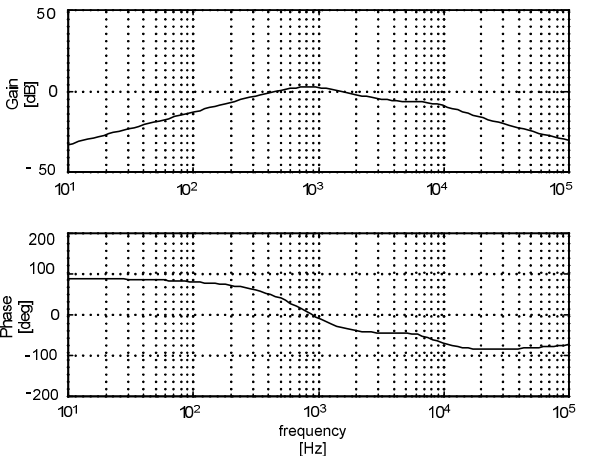

(b) Output impedance response at worst case

Figure 9. Disturbance performance at worst condition

IV. Conclusion

This paper introduced EDF general modeling of

LEO small satellite converter system and analyzed stabilization control design. The performance prediction of LEO small satellites power system is typically critical. Because of verity controller and rectification value, it is hard to computation and test implementation. So, this approach has merit that will reduce cost and make more reliable system. Furthermore, it can be constraint of converter specification and controller design.

Reference

[1] R. L. Steigerwald, "A Comparison of Half-Bridge Resonant Converter Topologies," IEEE Trans. On Power Electron., Vol. PE-3, pp. 174-182, Apr. 1988.

[2] A. Charette, K. Al Haddad R. Simard and V. Rajagopalan, "Variable Frequency and Variable Phase Shift Control of Dual Series Resonant Converter for Utility Interface," IECON' 88, pp. 563-568.

[3] Vivek Agarwal, A. K. S. Bhat, "Small Signal Analysis of the LCC-Type Parallel Resonant Converter Using Discrete Time Domain Modeling," IEEE Trans. On Industrial Electronics, Vol. 42, No. 6, Dec. pp. 604-614, 1995.

[4] G. C. Verghese, M. E. Elbuluk, and J. G.. Kassakian, "A General Approach to Sampled-data Modeling for Power Electronic Circuits," IEEE Trans. On Power Electron., PE-1, (2), pp. 76-89, 1986.

[5] S. Hamamura and D. Kurose, "New control method of piezo electric transformer converter by PWM and PFM for wide range of input voltage" CIEP'00, pp.3-8, Oct. 2000.

저 자

윤 석 택(Seok-Teak Yun) 정회원



2005년 7월 : 포항공과대학교
전기전자공학과 학사졸업
2007년 8월 : 서울대학교 전기컴퓨터
공학부 석사졸업
2007년 8월 ~ 현재 : 한국항공우주연구
원 재직

<관심분야> 위성전력, 전력전자공학

원 영 진(Young-Jin Won) 정회원



2001년 2월 : 경북대학교 전기전자공
학과 학사졸업
2003년 2월 : 포항공과대학교 전기전
자공학과 석사졸업
2005년 8월 ~ 현재 : 한국항공우주연구
원 재직

<관심분야> 안테나 설계, RF 시스템 설계

이 진 호(Jin-Ho Lee) 정회원



1990년 2월 : 광운대학교 전자공학과
학사졸업
1992년 8월 : 광운대학교 전자공학부
석사졸업
1992년 9월 ~ 현재 : 한국항공우주연구
원 재직

<관심분야> 위성 시스템, 위성 전자