

---

Original Paper

---

# Air-Water Two-Phase Flow Performances of Centrifugal Pump with Movable Bladed Impeller and Effects of Installing Diffuser Vanes

Shinji Sato<sup>1</sup>, Akinori Furukawa<sup>2</sup>

<sup>1</sup>Department of Mechanical Engineering, Tsuyama National College of Technology  
624-1 Numa, Tsuyama, Okayama, 708-8509, Japan, ssato@tsuyama-ct.ac.jp

<sup>2</sup>Department of Mechanical Engineering, Kyushu University  
744 Motooka, Nishi-ku, Fukuoka, 819-0395, Japan, fmfuru@mech.kyushu-u.ac.jp

## Abstract

It's known that pump head of centrifugal impeller with larger blade outlet angle is kept higher in air-water two phase flow condition, though the efficiency in water single phase flow condition is inferior. In the present study, a centrifugal impeller with variable blade outlet angles, that has higher efficiencies in both water single phase flow and air-water two phase flow conditions, is proposed. And the performances of the centrifugal impeller with variable blade outlet angles were experimentally investigated in both flow conditions of single and two-phase. In addition, effects of installing diffuser vanes on the performances of centrifugal pump with movable bladed impeller were also examined. The results are as follows: (1) The movable bladed impeller that proposed in this study is effective for higher efficiency in both water single phase and air-water two phase flow conditions. (2) When diffuser vanes are installed, the efficiency of movable bladed impeller decreases particularly at large water flow rate in water single-phase flow condition; (3) The performances of movable bladed impeller are improved by installing of diffuser vanes in air-water two-phase flow condition at relatively small water rate. The improvement by installing of diffuser vanes however disappears at large water flow rate.

**Keywords:** Centrifugal pump, Variable blade angle, Air-Water two-phase flow performance, Diffuser vane

## 1. Introduction

Generally, the centrifugal impeller with blade outlet angle of  $\beta_{b2}=22.5^\circ$  (recommended value by Stepanoff) has higher efficiency in water single phase flow[1]. However, pump head breakdown due to an air-water two phase flow occurs at a gas/liquid volumetric flow rate ratio of less than about ten percent for conventional types of turbo pumps with this blade outlet angle[2] [3]. On the other hand, it's known that pump head of centrifugal impeller with larger blade outlet angle is kept higher in air-water two-phase flow condition, though the efficiency in water single-phase flow condition is inferior[4][5]. This fact implies that high efficiency operation becomes possible in both water single phase flow and air-water two phase flow conditions by use of centrifugal pump impeller with variable blade outlet angles. In addition, the authors confirmed that the installation of diffuser vanes is effective for the improvement of air-water two-phase flow performances of a centrifugal pump[6].

In the present paper, pump performances of the centrifugal impeller with variable blade outlet angles in both water single-phase flow and air-water two-phase flow conditions are described. Then effects of installing diffuser vanes on the performances of centrifugal pump with movable bladed impeller are also discussed.

## 2. Experimental Apparatus

Figure 1 shows a cross section of tested pump with a vertical rotating shaft. Water is drawn into the pump through a boost pump from an open tank, while air, pressurized by a compressor, is blown from a nozzle into the suction pipe. The air/water mixture flows into a test impeller and returns to the tank through a scroll and delivery pipe. The pump speed was kept at  $N=1200\text{rpm}$  for the impeller with outlet blade angle  $\beta_{b2}=25^\circ$  or  $900\text{rpm}$  for impeller with  $\beta_{b2}=90^\circ$  after confirming the similitude and the suction pressure is constant as  $P_s=0.1\text{MPa}(\text{gauge})$ . The height of the scroll,  $B$ , which could be changed from 25 to 55mm by using the movable wall, was constant as 55mm in the present study. Air and water flow rates were measured by each orifice meter and normalized as flow coefficients,  $\phi_G$  and  $\phi_L$  by dividing a product of the cross-sectional area,  $A_2$ , and the rotational speed,  $U_2$  at the impeller outlet. Air flow rate was evaluated with water temperature and pressure at section ① of the suction pipe.

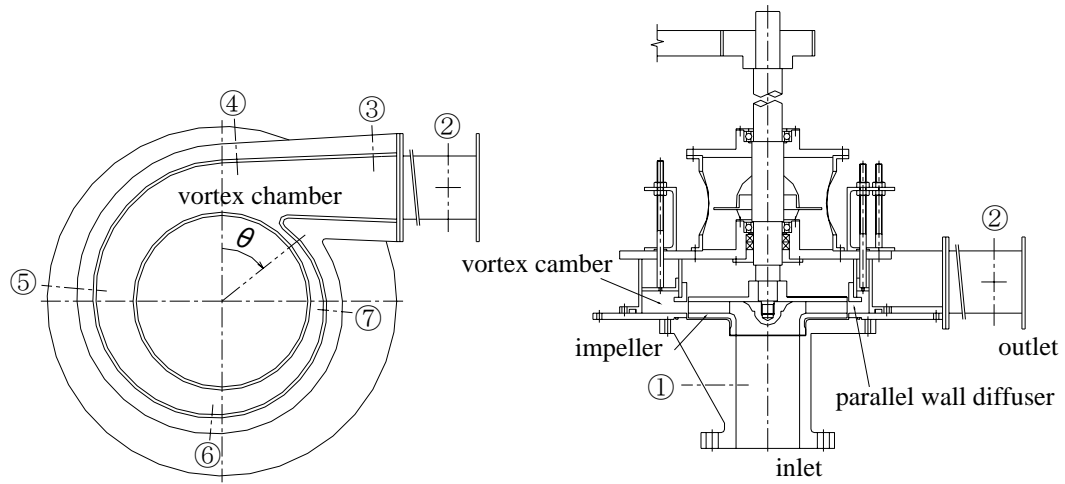

Fig. 1 Tested pump

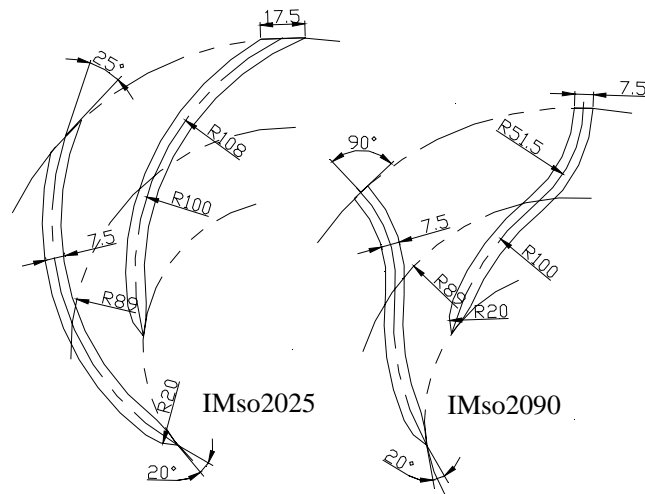
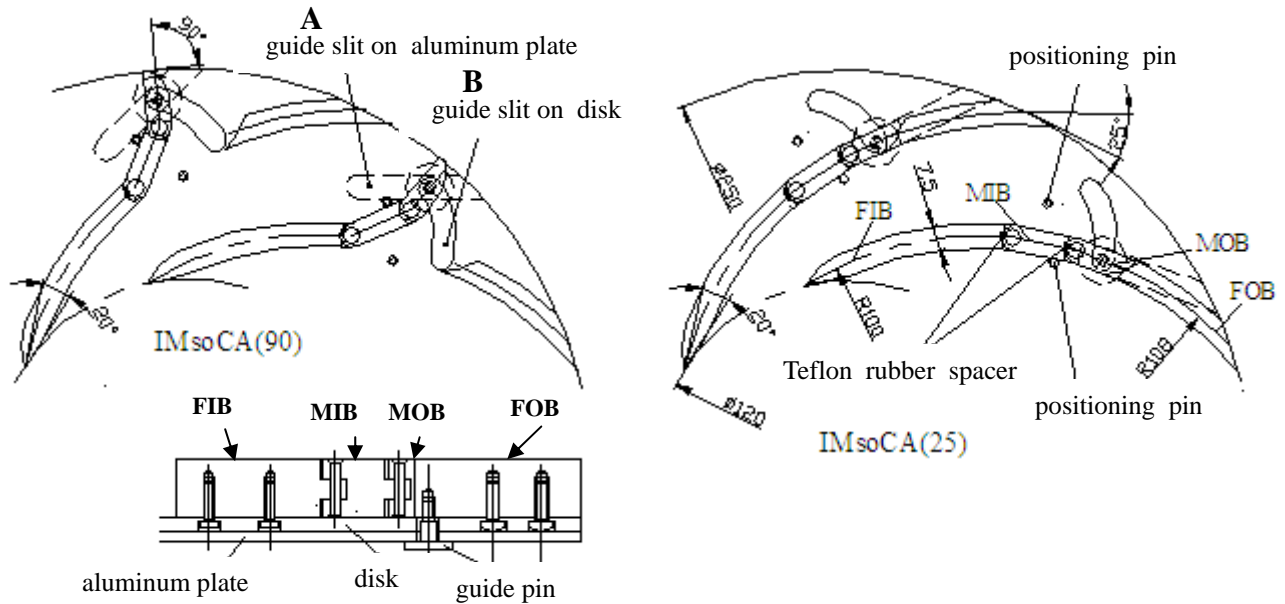

Fig. 2 Impellers with fixed blades

The pump head was obtained from difference between the measured static and assumed dynamic head assumed as homogeneous flow between sections ① and ③, and normalized as head coefficient  $\phi$  with  $U_2^2/g$ . Here  $g$  is denoted as the acceleration of gravity. Gas behavior in the impeller was observed through the transparent shroud casing with help of video equipment and a stroboscopic light. Tests were conducted by increasing air flow rate to the maximum of the pump operable range of  $\phi_G$  under  $\phi_L = \text{constant}$ . In the present paper, measured results will be shown with the measurement uncertainty corresponding to the size of symbols in each figure.

Figure 2 shows the shapes of fixed bladed impellers of centrifugal impellers. Both impellers have the same blade inlet angle of  $20^\circ$  meaning of shock-less entry at flow coefficient of  $\phi_{LS} = 0.069$  and different blade outlet angles of  $\beta_{b2}$ , one of which is  $\beta_{b2} = 25^\circ$  for IMso2025 and the other is  $90^\circ$  for IMso2090. In the designation of impeller IMso2090, “so” express as semi-open impeller and “2090” means blade inlet and outlet angles of  $20^\circ$  and  $90^\circ$ . In previous study[4], the efficiency of IMso2025 is higher at the designed flow rate than that of IMso2090 in water single flow condition while the efficiency of IMso2025 becomes inferior to that of IMso2090 in air-water two-phase flow condition. This fact implies the application of movable bladed impeller in the present paper as follows.

Figure 3 shows the shapes of centrifugal impeller with variable blade outlet angles and mechanism of how to change the blade outlet angle. Blade inlet angle of the impeller is fixed at  $20^\circ$  (flow coefficient of  $\phi_{LS} = 0.069$  with shockless entry) and outlet angle  $\beta_{b2}$  is variable to  $25^\circ$  and  $90^\circ$ . In the designation of IMsoCA(\*\*) the figures of 25 and 90 in parentheses indicate blade angles at outer diameter of the impeller. The shapes of IMsoCA(25) is the same as IMso2025 while that of IMsoCA(90) is considered as reproducing the impeller blade of IMso2090. The blade shape of IMso2025 is divided into four parts of FIB, MIB, MOB and FOB in order from the inlet to outlet as seen in IMsoCA(25) of Fig.3. The parts of FIB, MIB and MOB are connected with hinges and pins at the connecting point of two circular arcs as drawn in IMso2090 of Fig.2 and the point of equally dividing the rear circular arc. Two parts of FIB and FOB are fixed on the disk. The part of FOB is remained in the flow passage in the case of IMsoCA(90) of Fig.3. It is considered to give little influence on two-phase flow performance because FOB is covered with the air cavity in air-water two phase flow condition as shown later. A mechanism of how to change the blade shapes between IMsoCA(25) and (90) is described as follows. The impeller has two rotating disks as shown as “disk” and “aluminum plate” as shown in Fig.3. On the disk



**Fig. 3** Centrifugal impeller with variable blade outlet angles and mechanism to change angle of impeller blades

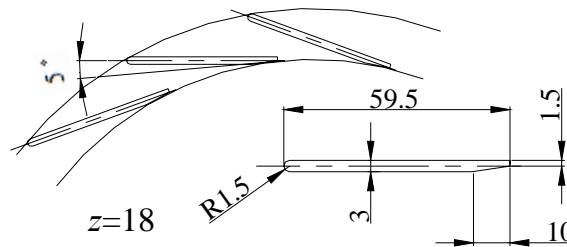

**Fig. 4** Shape of diffuser vanes

parts of FIB and FOB are fixed. There is guide slits “B” on the disk, where the guide pin, combining between MOB and the aluminum plate, can be moved for change of blade outlet angle. The aluminum plate has guide slits “A” and the guide pin is moved in guide slit “A” when outlet blade angle is changed. The part of MIB is freely supported by FIB and MOB through a hinge and pin. Then the blade outlet angle can be changed by rotating the aluminum plate independent of the disk. The shape of circular arc on the suction surface of the MOB outlet is given to increase the pump head. Then the leading edges of FOB becomes sharpened as shown in Fig.3 There are incisions in the tips of MIB and MOB where the spacers made of Teflon rubber are installed to prevent the leakage flow and head deterioration.

Both of the impellers with movable blades and fixed blades are experimentally investigated in the state that removed only front shroud as semi-open impeller because the proposed mechanism for movable blade outlet angle cannot release opening a disk side, though it is known that the impeller tip opening is effective for improvement of air-water two phase flow performances[7]. The gap between the edge of the blade and the shroud casing is  $s=1\text{mm}$  against impeller blade height  $b=18\text{mm}$ . The experiments of the impeller with variable blade outlet angles have been performed in the state that aluminum plate is fixed to the disk with screws at the position of large or small blade outlet angle.

The shape of diffuser vanes which are installed at the downstream section of 1.5mm from the impeller blade outlet, is shown in Fig.4. This diffuser vane is designated as LV5. In air-water two-phase condition, as the air cavity appears in the impeller outlet and elongates downstream with head deterioration, the cavity enters the passage between the diffuser vanes with the water flow and cut off by diffuser vanes[6]. The diffuser vanes have the overlap to be swept away air effectively by increasing the water flow velocity in flow passage of diffuser vanes. The number of the diffuser vanes was decided to  $z=18$  against the number of the impeller blades was  $z=8$ , based on an idea that it is necessary that the number of diffuser vanes is more than the number of impeller blades to crush the air cavity formed at the exit of the passage between the impeller blades. The installation angle of the diffuser vanes was decided as  $\beta_{b3}=5^\circ$  that slightly smaller than the flow angle expected in the water single phase flow.

### 3. Experimental Results

#### 3.1 Pump performances in single phase flow

Figure 5 shows changes of pump performances with flow rate in single phase flow for IMsoCA(25), that is the movable bladed impeller with small blade outlet angle, as ▲ and for IMso2025 and IMso2090 without diffuser vanes, that are fixed bladed

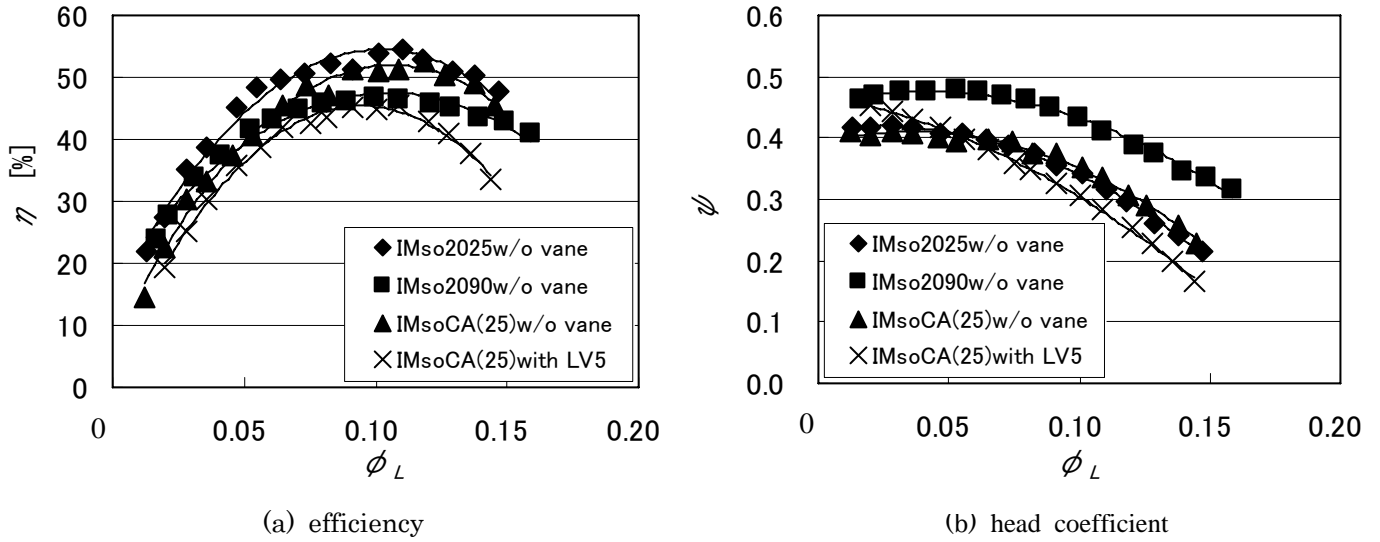

**Fig. 5** Comparisons of pump performances in single phase flow

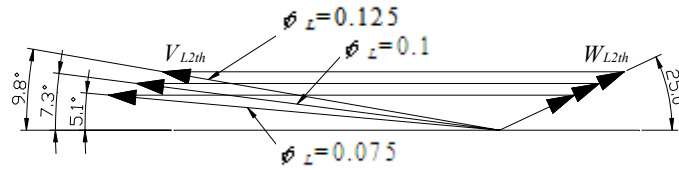

**Fig. 6** Conceptual explanation on changes of velocity triangles at impeller outlet

impellers without diffuser vanes as  $\blacklozenge$  and  $\blacksquare$  respectively.

Results on the efficiency are compared in Fig.5(a). In the comparison among the fixed and movable bladed impellers without diffuser vanes, the efficiency of IMso2025 with  $\beta_{b2}=25^\circ$ , which is near the recommended value by Stepanoff[1], is the highest. The impeller IMsoCA(25), having the same blade outlet angle of  $25^\circ$  as IMso2025, indicates lower efficiency than that of IMso2025 in the range of small flow coefficient and becomes approximately the same value as that of IMso2025 in the range of  $\phi_L \geq 0.1$ . The impellers of IMso2025 and CA(25) give higher efficiencies than that of IMso2090 with  $\beta_{b2}=90^\circ$ . On the other hand, in a whole water flow rate range, IMso2090 indicates the highest pump heads whereas pump heads of IMso2025 and IMsoCA(25) with the same blade outlet angle have almost the same level as seen in Fig.5(b).

Effects of presence of diffuser vanes are shown in Fig.5 for IMsoCA(25), which would be operated in water single phase flow condition. When the diffuser vanes are installed, the efficiencies becomes lower in a whole range of water flow rate, and the head coefficient are lower in the larger water flow rate range of  $\phi_L \geq 0.05$ . These differences between impellers with and without diffuser vanes become larger with increase of water flow rate. It is considered as this cause that the flow velocity increasing due to the increase of water flow rate brings about pressure loss and the shock loss by the vane inlet separation becomes larger as the absolute velocity flow angle becomes larger than the installation angle of the diffuser vanes. Figure 6 shows a conceptual explanation on changes of velocity triangles at impeller outlet in single phase flow. The absolute velocity flow angle at  $\phi_L=0.075$  is almost the same angle as the installation angle  $5.1^\circ$  of the diffuser vanes. Then it becomes  $7.3^\circ$  at  $\phi_L=0.1$  and  $9.8^\circ$  at  $\phi_L=0.125$ , meaning the negative incidence for diffuser vanes. This negative incidence causes the shock loss increasing and separation occurring on the pressure side of diffuser vane inlet. The mismatch of the installation angle of the diffuser vane for flow velocity angle might cause the pump head drop at larger flow coefficient.

### 3.2 Pump performances in air-water two-phase flow

Air-water two phase flow performance tests were conducted by increasing air flow rate to the maximum of the operable range of  $\phi_G$  under  $\phi_L=\text{constant}$ . Figure 7 and 8 show pump head and efficiency characteristics of IMsoCA(90), that is the movable bladed impeller with  $\beta_{b2}=90^\circ$ , in air-water two phase flow condition in comparison with those of the fixed bladed impellers IMso2025 and IMso2090 without diffuser vanes.

The pump head characteristics shown in Fig.7 are considered here. It is found as difference according to blade outlet angle that the head coefficients  $\psi$  of IMsoCA(90) and IMso2090 with  $\beta_{b2}=90^\circ$  are higher than that of IMso2025 with  $\beta_{b2}=25^\circ$  in the water flow rate range of  $\phi_L \geq 0.033$ , although this trend becomes weakened at  $\phi_L=0.016$  because the large air accumulating regions appear in the impeller passage by air flow entering a little. The higher head in two-phase flow condition due to  $\beta_{b2}=90^\circ$  is caused by the increase of Euler's head due to having large blade outlet angle. Results of fixed and movable impellers IMso2090 and IMsoCA(90) with the same blade outlet angle are compared. Although IMso2090 indicates higher pump heads in the low air-water mixing ratio range of  $\phi_G/\phi_L \leq 15\%$  in a whole water flow rate range except  $\phi_L=0.016$ , with increase of air-water mixing ratio  $\phi_G/\phi_L \geq 15\%$  pump heads of IMso2090 and IMsoCA(90) have almost the same level. The causes are considered as follows. The

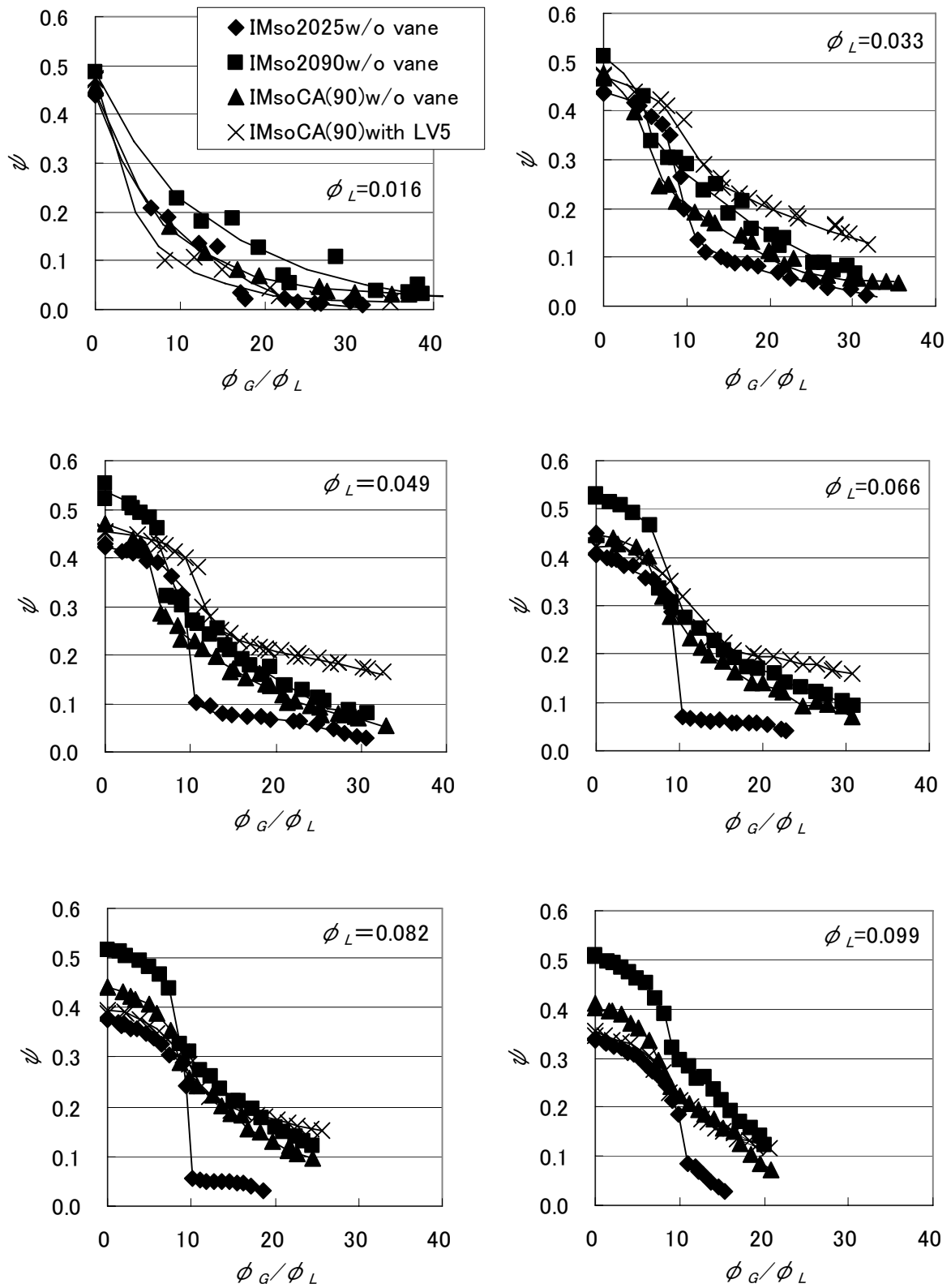

**Fig. 7** Head degradations in two-phase flow condition

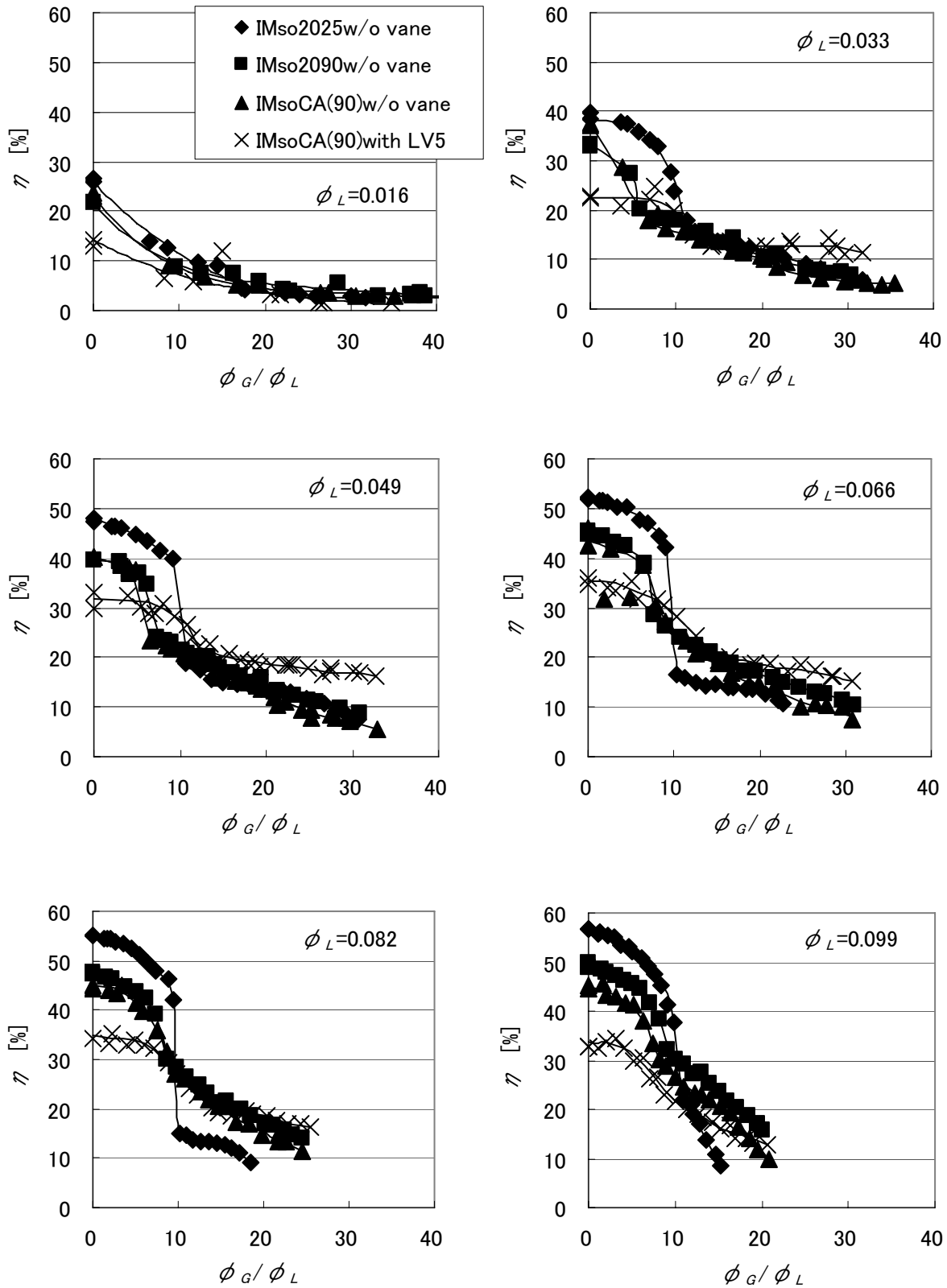

**Fig. 8** efficiency degradations in two-phase flow condition

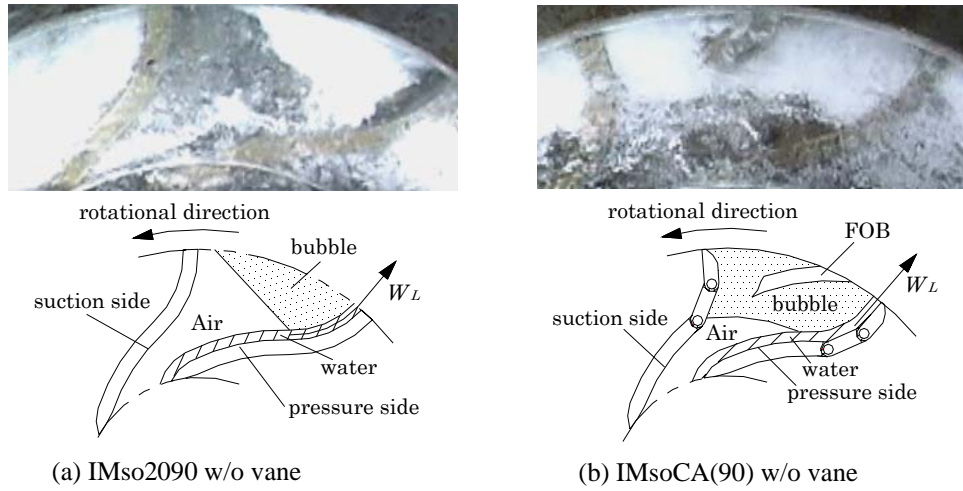

**Fig. 9** Air behavior in impellers at  $\phi_L=0.033$ ,  $\phi_G/\phi_L=15\%$

leakage flow from the gap of movable blades connection bring about loss in the low air-water mixing ratio range, while this leakage flow enables to suppress air accumulating region occurring and elongation in the impeller in the high air-water mixing ratio range. The existing of blade FOB, located in the centered position of flow passage, also suppresses the elongation of the air accumulating region. The efficiency characteristics shown in Fig.8 are considered here. The efficiencies of IMsoCA(90) and IMso2090 are higher than that of IMso2025 in the high air-water mixing ratio range of  $\phi_G/\phi_L \geq 15\%$  in a whole water flow rate range except  $\phi_L=0.016$ , although the efficiencies of these impellers with  $\beta_{b2}=90^\circ$  are lower than that of IMso2025 with  $\beta_{b2}=25^\circ$ , which is near the recommended value by Stepanoff, in the low air-water mixing ratio range of  $\phi_G/\phi_L \leq 15\%$ . In the comparison among fixed and movable impellers IMso2090 and IMsoCA(90) with the same blade outlet angle, the efficiencies of IMso2090 and IMsoCA(90) have almost the same level in a whole water flow rate range. Figure 9 shows air behavior in impellers at  $\phi_L=0.033$  and  $\phi_G/\phi_L=15\%$ . In the case of IMso2090, the obvious region of air accumulation appears in the suction side of impeller outlet as Fig.9(a). In the case of IMsoCA(90), the cloudy bubble flow appears around blade FOB and air accumulating region becomes shortened as Fig.9(b). This originates the fact that the leakage flow from the gap of movable blades connection enables to suppress air accumulating region occurring and elongation in the impeller and the existing of blade FOB suppresses air accumulating region elongation as previously stated. It is clarified from above mentioned results that having large outlet blade angle by the movable bladed impeller is effective to improvement of air-water two phase flow performance.

Effects of presence of diffuser vanes are also shown in Figs.7 and 8 for IMsoCA(90), which would be operated in air-water two-phase flow condition with high mixing ratio. When the diffuser vanes are installed head coefficient becomes higher as  $\times$  in Fig.7 than that without diffuser vanes as  $\blacktriangle$  in Fig.7 in small and medium water flow rate range to  $\phi_L=0.066$  except  $\phi_L=0.016$ . It is considered as this difference that the diffuser vanes have roles not only to rectify the flow effectively with pressure recovery and also to cut the air accumulation region from the impeller outlet with crushing. On the other hand, the improvement by installing the diffuser vanes cannot be confirmed in large water flow rates of  $\phi_L=0.082$  and  $0.099$ . It is considered that the pump head in water single phase flow drops because of increasing pressure loss and shock loss with inlet separation as previously stated, although the head decrease due to the inflow of the air becomes gradual by installing diffuser vanes. This can be clearly inferred from the results in Fig.8. Therefore, this consideration may introduce the further improvement by selecting the installation angle and the shape of the diffuser vanes appropriately.

#### 4. Concluding Remarks

The performances of centrifugal pump with movable bladed impeller in both water single-phase and air-water two-phase flow conditions were experimentally investigated. The results on effects of various blade outlet angles and installing diffuser vanes were discussed in comparison with those of fixed bladed impellers. The following are the main conclusions obtained from the present study.

- (1) The movable bladed impeller, proposed in this study, is effective for higher efficiency operation in both water single phase and air-water two-phase flow conditions. Pump performances of movable bladed impeller are approximately equal to the performances of fixed bladed impeller with high blade outlet angles in the high air-water mixing ratio range. There is, however, a little decrease of performance for movable bladed impeller with the low blade outlet angles in single-phase flow operation.
- (2) When the diffuser vanes are installed, the efficiency of movable bladed impeller decreases particularly at large water flow rate in water single-phase flow because of increasing shock loss with inlet separation due to the difference between installing blade angle and inlet flow angle.
- (3) The performances of movable blade impeller are improved by installing of diffuser vane in air-water two phase flow condition at relatively small water rate. The improvement by installing of diffuser vane, however, cannot be confirmed at large water rate.

## References

- [1] Stepanoff, A. J., 1948, "Centrifugal and Axial Flow Pumps," John Wiley & Sons, Inc.
- [2] Furukawa, A. and Sato S., 1994, "Air-Water Two-phase Flow Performance of Turbo Pump," Turbomachinery (in Japanese), Vol. 22, No. 11, pp. 665-670.
- [3] Kosmowski, I., 1988, "Dimensionierung von Pumpen für die Forderung von asbeladenen Flüssigkeiten," Pumpen- und Verdichter Informationen (in German), No. 1, pp. 43-46.
- [4] Sato, S., Furukawa, A. and Takamatsu, Y., 1996, "Air-Water Two-Phase Flow Performance of Centrifugal Pump Impellers with Various Blade Angles," JSME International Journal, Ser. B, Vol. 39, No. 2, pp. 223-229.
- [5] Minemura, K., Uchiyama, T., Ihara, M. and Furukawa, H., "Numerical Prediction of Two-Phase-Flow Pump Performance by a Bubbly Flow Model with Fixed Cavity," Transactions of JSME (in Japanese), Ser. B, Vol. 60, No. 571, pp. 920-925.
- [6] Sato, S., Asano, Y. and Furukawa, A., 2000, "Influences of Vaned Diffuser of Centrifugal Pump on Air-Water Two-phase Flow Performance," Bulletin of Tsuyama National College of Technology (in Japanese), No. 42, pp. 1-4.
- [7] Sato, S., Asano, Y. and Furukawa, A., 1995, "Studies on Air-Water Two-Phase Flow Performance of a Centrifugal Pump with Open Impeller," Bulletin of Tsuyama National College of Technology (in Japanese), No. 37, pp. 11-15.