

실험실용 독립형 하이브리드 에너지 시스템의 가능성 연구

논문
58P-4-50

Pre-Feasibility Study of Stand-Alone Hybrid Energy System for Applications in a Lab

이 영* · 최 용 성[†] · 張 尤 賽** · 이 경 섭***
(Ying Li · Young-Sung Choi · You-Sai Zhang · Kyung-Sup Lee)

Abstract - As renewable and sustainable energy, solar energy and wind energy have advantages in reducing the pollution sources. The paper presents a hybrid system which includes the solar cell and the wind generator. HOMER provides a platform to design and simulate the power system and then to choose the optimization results. This paper simulates with the HOMER and performs a pre-feasibility study of stand-alone hybrid energy systems for applications in a lab.

Key Words : Solar Cell, Wind Generator, Hybrid Energy System, Renewable Energy, HOMER

1. Introduction

The world's energy structure has a major change from fossil energy system to renewable and sustainable energy system. And the renewable energy sources include solar energy and wind energy. Furthermore, as devices which supply new, clean and renewable energy, solar cell and wind generator are energy transformation technologies. Solar cell is a kind of device which using the interaction of sunlight and materials to generate electrical energy [1]. The principle of wind power is the use of wind driven windmill blade rotation, and then through the growth machine will improve the speed of rotation, to encourage power generators. The wind energy into electricity using wind energy is the most fundamental way [2]. The HOMER Micropower Optimization Model is a computer model developed by the U.S. National Renewable Energy Laboratory (NREL) to assist in the design of micropower systems and to facilitate the comparison of power generation technologies across a wide range of applications [3]-[7].

The object of the study is to optimize various energy sources in a lab which has some base loads occur throughout the day and night and some majority loads occur in day or in night. Based on the data of the loads demand and power supply, utilizing the HOMER, a simulation about supply

demand relationship can be done and from the simulation results, the optimization results can be presented.

2. Hybrid System

Generally, a hybrid energy system consists of several energy sources and relative components. In this paper, the hybrid system includes solar cells, wind generator, convertor and generator. The type of the wind generator is SW AIRX(3). Table 1 shows the technical data of hybrid system components. Among these components, two generate electricity from intermittent renewable sources: solar cells and wind generator. Here, the rated power of the solar cells is 0.8 kW and the type of the wind generator is SW AIRX (3) whose rated power is 0.55 [kW]. The cost of the solar cells is the most expensive and the lifetime of the solar cells is the longest.

Fig.1 shows the proposed scheme as implemented in the HOMER simulation tool. The generator is considered because the solar cells cannot supply power to the load at nights and the wind generator cannot work in windless day. So it improves the stability of the hybrid system. The convertor transforms the DC power which is generated by the solar cell and wind generator to AC power that can be utilized by the loads.

2.1 Load

The lab loads consist of notebook, desktop, printer, fluorescent lamp, refrigerator and experimental apparatus. The total daily load averages 1.8 [kWh/day], with a peak load of 1.3 [kW]. Fig. 2 and Fig. 3 present the hourly load in the lab for weekday and weekend. The demand loads of weekday are more than the ones of the weekend. In

[†] 교신저자, 시니어회원 : 동신대 공대 전기공학과 교수 · 공박
E-mail: yschoi67@dso.ac.kr

* 준 회 원 : 동신대 대학원 석사과정

** 비 회 원 : 중국강소과학기술대학 전자정보학원 교수 · 공박

*** 시니어회원 : 동신대 공대 전기공학과 교수 · 공박

접수일자 : 2009년 11월 6일

최종완료 : 2009년 11월 21일

particular, the demand loads are increasing during the night in weekday because of the experiments. During the weekend, besides the base loads like the refrigerator and experimental desktop to measure and save the experimental data, there are some usages of the other loads occasionally. The peak load in weekend is 0.75 [kW]. The total demand power of the weekend is much less than the weekday's.

Table 1 The technical data of hybrid system components.

Component	Size	Capital Cost [\\$]	Replacement Cost [\\$]	O&M Cost [\\$]	Lifetime
Solar cells	0.8kW	7000	200	0.00	25 years
SW AIRX(3)	0.55kW DC	2500	200	0.00	15 years
Converter	1kW	500	100	0.00	15 year
Generator	1kW	1000	200	0.00	15000 hours

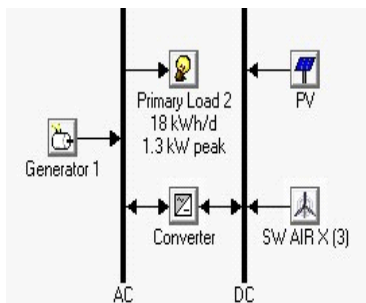

Fig. 1 HOMER implementation of the hybrid energy system.

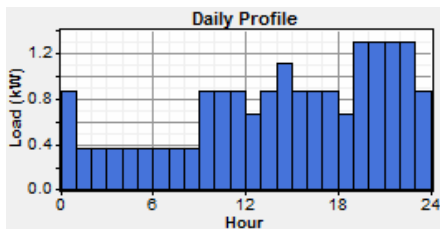

Fig. 2 Hourly load profile for weekday

2.2 Renewable resources

2.2.1 Solar energy resource

From the New & Renewable Energy Resource Map Data Center, it got the Kwangju radiation monthly. Fig. 4 illustrates the radiation and clearness index profile over a one-year period in Kwangju. During April to September, the solar radiations are more than other time of the year.

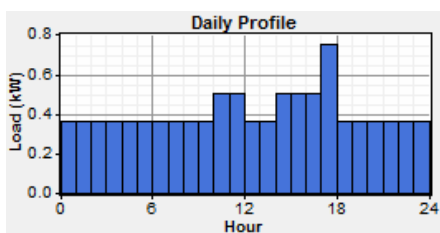

Fig. 3 Hourly load profile for weekend

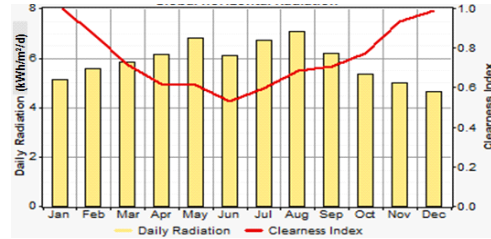

Fig. 4 Solar Radiation profile for Kwangju [8].

2.2.2 Wind energy resource

From the New & Renewable Energy Resource Map Data Center, it got the Kwangju wind speed monthly. Fig. 5 illustrates the wind speed profile over a one-year period in Kwangju. During March, April and July, the wind speeds are more than other time of the year.

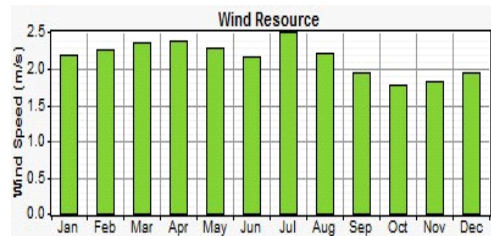

Fig. 5 Wind speed profile for Kwangju [8].

2.2.3 Generator

Solar energy and wind energy are extreme intermittent and inconstant energy sources, so the only usage of the solar energy and wind energy has poor effect to the stability and reliability of the power supply. Especially, the generator is the main power supply in the hybrid system at night or at windless time. In Fig. 6, capital cost and replacement cost of the generator are assumed to be 500 dollars and 100 dollars.

3. Results and Discussions

Three sensitivity variables (solar irradiation, wind speed and diesel price) are considered in this paper. Based on Fig. 4, the average radiation is verified from 4.500 [kWh/m/d] to 7.000 [kWh/m/d] and has 6 values. It shows in Fig. 7. Based on Fig. 5, the average speed wind is verified from 1.700 [m/s] to 2.400 [m/s] and has 9 values. It shows in Fig. 8.

The important effect factor of the generator was the diesel price, in this paper, the diesel price is verified from 0.400 [\$/L] to 0.600 [\$/L] and has 3 values. It shows in Fig. 9.

A total of 162 sensitivity cases (product of solar radiation (6), wind speed (9) and diesel price (3)) were tested with each of the system configurations. The optimization results are presented in Fig.10. Here, the solar radiation is assumed as 5.63 [kWh/m/d] which is

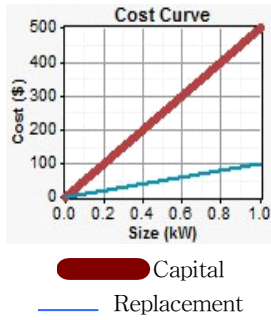

Fig. 6 Diesel generator cost curves.

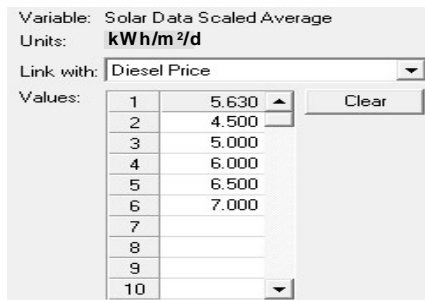

Fig. 7 The range of the solar radiation

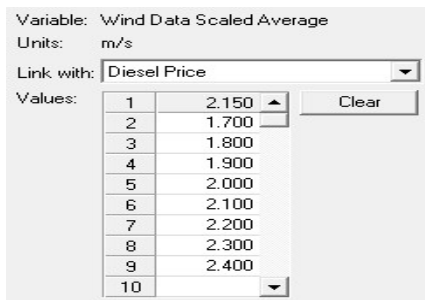

Fig. 8 The range of the wind speed

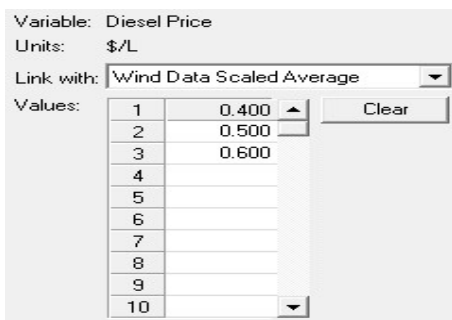

Fig. 9 The range of the diesel price

the average value. The wind speed is assumed as 2.15 [m/s] which is the average value. Because the diesel price is fluctuant, and the diesel price was 0.484 [\$/L] in 2009, 10, 30 [9], the diesel price is assumed as 0.500 [\$/L].

From the Fig. 10, it can get that the most cheap sensitivity case is the first group, the COE (Cost of

Electricity) is 0.334 [\$/kWh], only use a generator whose the rated power is 2 [kW]. But in this case, the pollutant is much more than the fourth case which include PV panel whose rated power is 0.8 kW, a wind generator whose rated power is 0.55 [kW], a diesel generator whose rated power is 2 [kW] and a convertor whose rated power is 1 [kW]. Though the COE of the fourth case is 0.454 [\$/kWh], it is more than other three cases, the fourth case has the most stability and reliability. In addition, the COE of the fourth case is not much more than the COE of the first case. Hence the fourth case is chosen as the best simulation results.

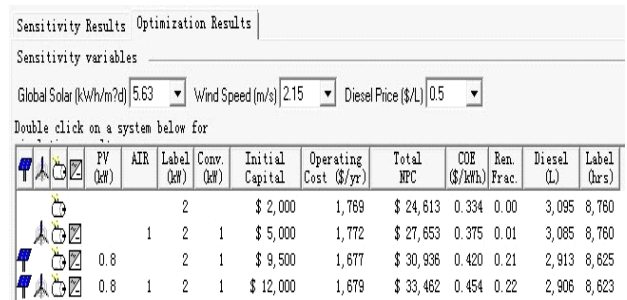
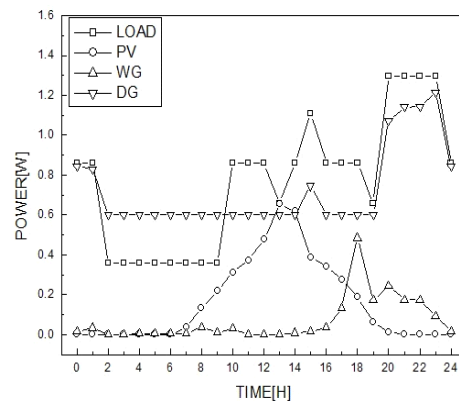
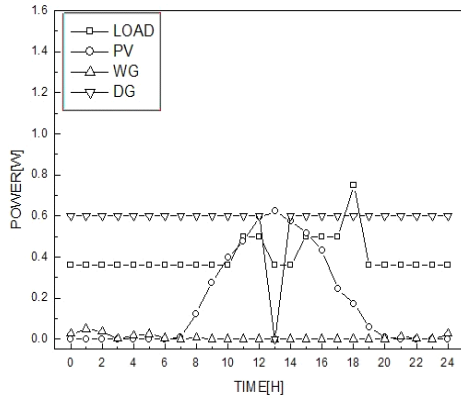

Fig. 10 The optimization results of the hybrid system.

Compared Fig. 4 and Fig. 5, during July, the synthetic effects of solar radiation and wind speed are better than others of the year. And during December, the synthetic effects of solar radiation and wind speed are worse than others of the year. Fig. 11 presents the hourly load and electrical production of the system for a weekday and a weekend of July. Fig. 11 (a) presents that during the weekday time, since the lab demand power is much, generator runs all day, and during the day time and the windy time, the solar cells and wind generator generate power to compensate the diesel generator. Fig. 11 (b) presents that during the weekend time, since the lab demand power only has the base loads, during the day time and the windy time, solar cells and wind generator can meet almost the entire loads in July.



(a) A weekday of July



(b) A weekend of July

Fig. 11 Hourly load and electrical production of the system for a weekday and a weekend of July.

Fig. 12 presents the hourly load and electrical production of the system for a weekday and a weekend of December. Fig. 12 (a) presents that during the weekday time, since the lab demand power is much, generator runs all day, and during the day time and the windy time, the solar cells and wind generator generate power to compensate the diesel generator. Fig. 12 (b)

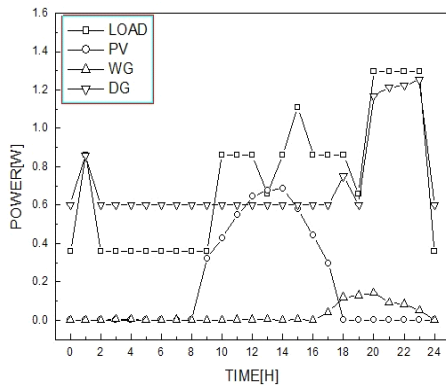

(a) A weekday of December

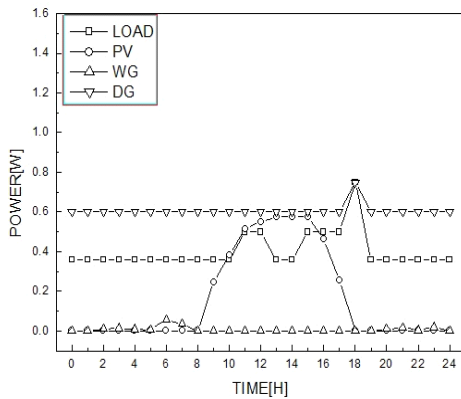

(b) A weekend of December

Fig. 12 Hourly load and electrical production of the system for a weekday and a weekend of December.

presents that during the weekend time, since the lab demand power only has the base loads, during the day time and the windy time, the ratio of the power supply which generated by the solar cells and wind generator is more than that of weekday. Even during the December, the solar radiation and wind speed are not ideal, solar cells and wind generator can also supply energy to the loads to compensate the diesel generator.

4. Conclusions

This paper performed a pre-feasibility study of stand-alone hybrid energy system for applications in a lab. The hybrid system includes solar cells and wind generator and diesel generator. Furthermore, a total of 162 sensitivity cases (product of solar radiation (6), wind speed (9) and diesel price (3)) were tested with each of the system configurations. In this paper, the following results were obtained:

1. Among the optimization results, considering pollution emission and COE, the case is chosen as the best way which includes solar cells whose rated power is 0.8 [kW], a wind generator whose rated power is 0.55 [kW], a diesel generator whose rated power is 2 [kW] and a convertor whose rated power is 1 [kW] and the COE is 0.454 [\$/kWh]. Four graphs show the hourly load and electrical production of the system for weekday and weekend of July and December to compare the different conditions under good solar radiation and wind speed as well as bad ones.
2. During the weekday time, since the lab demand power is much, generator runs all day, and during the day time and the windy time, the solar cells and wind generator generate power to compensate the diesel generator. During the weekend time, since the lab demand power only has the base loads, during the day time and the windy time of July, solar cells and wind generator can meet almost the entire loads. Even during the December, the solar radiation and wind speed are not ideal, solar cells and wind generator can also supply energy to the loads to compensate the diesel generator. Thereby, the utilizations of the hybrid system reduce the total emissions of the pollutants.

Acknowledgement

This work was supported by the Grant of the Korean Ministry of Education, Science and Technology" (The Regional Core Research Program/Biohousing Research Institute)

References

- [1] ZHI-XIU CHENG and XIAO-LI WANG, "The Expatiates of the Solar Energy Photovoltaic Cell," Information Recorded Material, Vol.8, pp.41-47 (2007).
- [2] <http://www.allwindenergy.com/hummer/post/wind-turbine-principle.htm>.
- [3] PAUL GILMAN and PETER LILIENTHAL National Renewable Energy Laboratory, TOM LAMBERT, Mistaya Engineering Inc.
- [4] 김찬혁, 박현석, 노대석, 신창훈, 윤기갑, "태양광발전이 연계된 배전시스템의 보호기기 오동작에 대한 최적 운용 방안에 관한 연구", 전기학회논문지, Vol.58, No.8, pp.1512-1518, 2009.
- [5] 이정훈, 김태오, 이홍희, "풍력발전 설비용 IEC 61400-25 기반 통신 시스템 구축", 전기학회논문지, Vol.58, No.7, pp.1356-1362, 2009.
- [6] 최정식, 고재섭, 정동화, "열전소자를 이용한 BIPV 모듈의 냉각시스템 개발", 전기학회논문지, Vol.57, No.9, pp.1555-1562, 2008.
- [7] 김종수, 최규영, 강현수, 이병국, "PCS 최적설계를 위한 고분자 전해질 연료전지의 동특성 모델링", 전기학회논문지, Vol.57, No.9, pp.1563-1571, 2008.
- [8] <http://kredc.kier.re.kr/>
- [9] <http://www.in-en.com/oil/quote/>.

저 자 소 개

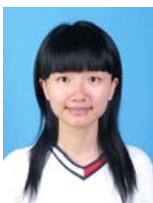

이 영 (李 盈)

She was born in 1985, received the BS degree in Electronics and Information of Science and Technology in 2007 and had taken MS course of Signal and Information Processing for one year in Jiangsu University of Science and Technology, China in 2008. Now she is studying toward the MS degree in Dept. of Electrical and Electronic Engineering in Dongshin University, Korea.

Tel : 061-330-3218

Fax : 061-330-3105

E-mail : yinglee.100@hotmail.com



최 용 성 (崔 龍 成)

He was born in Korea in 1967. He received his B.S., M.S. and Ph.D. degrees in Electrical Engineering from Dong-A University in 1991, 1993 and 1998, respectively. He was employed as a Post-doctoral Fellow at the Japan Advanced Institute of Science and Technology from 1999 to 2000. He then worked with Osaka University as a JSPS Fellow from 2001 to 2002. He had also worked as a Research Professor at Wonkwang University from 2002 to 2005. He joined Dongshin University in 2006. His main research interests are in the areas of biotechnology (biochip), high voltage and discharge and its applications.

Tel : 061-330-3204

Fax : 061-330-3105

E-mail : yschoi67@dsu.ac.kr

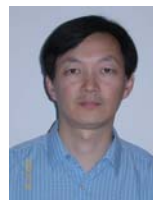

You-Sai Zhang (張 尤 賽)

You-Sai Zhang, was born in 1959, received the MS degree in Dongnan University and Ph.D. in engineering degree in Tongji University, in 1991 and 2003, respectively. Promoted to be a professor in 2004, now is the subdecanal of the institution of electronic and information, Jiangsu University of Science and Technology and the member of Chinese Image and Graphics Institution and Chinese National Universities Research Association of Electronic Technology.



이 경 섭 (李 炘 燮)

He was born in Korea in 1956. He received his B.S., M.S. and Ph.D. degrees in Electrical Engineering from Chosun University in 1983, 1983 and 1991, respectively. He joined Dongshin University in 1988. His main research interests are in the areas of NT, BT, high voltage and discharge and its applications.

Tel : 061-330-3201

Fax : 061-330-3105

E-mail : kslee@dsu.ac.kr