

FEA - Based Optimal Design of Permanent Magnet DC Motor Using Internet Distributed Computing

Cheol-Gyun Lee^{*★}, Hong Soon Choi^{**}

Abstract

The computation time of FEA(finite element analysis) for one model may range from a few seconds up to several hours according to the complexity of the simulated model. If these FEA is used to calculate the objective and the constraint functions during the optimal solution search, it causes very excessive execution time. To resolve this problem, the distributed computing technique using internet web service is proposed in this paper. And the dynamic load balancing mechanisms are established to advance the performance of distributed computing. To verify its validity, this method is applied to a traditional mathematical optimization problem. And the proposed FEA-based optimization using internet distributed computing is applied to the optimal design of the permanent magnet dc motor(PMDCM) for automotive application.

Key words: Distributed computing, web services, optimal design, permanent magnet DC motor, finite element analysis

I. Introduction

The permanent magnet DC motor(PMDCM) for automotive application should have high torque, high efficiency, low weight and small volume because of the constraints of installation space and low fuel consumption. Therefore the optimal design is tried to meet all the requirement given simultaneously when we design PMDCM. Meanwhile, the rotor structure of PMDCM has the axial duct to take advantage of high ventilation effect and reduction of motor weight. Therefore, it is required to use

electromagnetic field finite element analysis for the accurate calculation of motor characteristics because of the complex rotor configuration and the saturation of rotor flux path. It takes longer computation time than using the lumped parameter method.

Due to the FEA simulations the assumptions on convexity and smoothness of objective and constraint functions are not valid any more [1]. Therefore, optimization algorithms with global convergence are needed. Genetic algorithm is used as optimization technique in this paper, because it is a promising search technique for finding global optimal solutions in large space [2]. The stochastic optimization technique such as genetic algorithm creates multiple numbers of candidates for each optimization step. Therefore, many hundreds or thousands of these FEA simulations to calculate objective and constraint functions during the optimal solution search cause very excessive execution time.

To resolve this problem, the parallel or distributed computing technique is needed. Instead of using

* Dept. of Electrical Eng., Dong-Eui University

**School of Electrical Eng., Kyungbuk University

★ Corresponding author

※ Acknowledgment

This work was supported by Dong-Eui University Foundation Grant(2008AA163) and KESRI (R-2007-2-060) which is funded by MOCIE (Ministry of Commerce, Industry and Energy).

Manuscript received Aug. 11, 2009 ; revised Sep. 23, 2009

traditional parallel hardware such as vector computer [3], the distribution in this paper will be realized via the internet web services. The tasks are divided up according to the number of the computers(servers) connected via internet. In recent years, the web services [4] using HTTP(Hypertext Transfer Protocol), XML(eXtensible Markup Language), and SOAP(Simple Object Access Protocol) are standardized as RPC(Remote Procedure Call) method in internet environment. And distribution computing with web services is being studied [5]-[7]. Such a method has many advantages; access to a number of computers in internet, ease of communication, reliability, and firewall friendly.

A Load balancing mechanism for distributed or parallel computing is needed because the total number of tasks should be done is larger than the number of connected servers. Therefore, the load balancing mechanism are also established to advance the performance of distributed computing in this paper.

The proposed method is applied to a traditional mathematical optimization problem to verify its validity. And it is applied to the FEA-based optimal design of the permanent magnet dc motor(PMDCM) for automotive application.

II. Internet Distributed Computing

2.1 Internet Web Service

The distribution scheme using internet web service proposed in this paper is shown in Fig. 1. The communication between the client and the computing servers are realized by internet's HTTP and SOAP protocols using web service. Web service technology comes mostly in the form of one server dealing with the tasks from multiple number of clients. But the distributed computing is another form of the web service technology where one client utilizes multiple number of servers.

The distributed computing as a form of the web service technology is, in many respects, different from the Message Passing Interface [8] and Parallel Virtual Machine [9] technologies which are, in general, for local area network, tightly coupled cluster or parallel environment. It deals with

multiple number of tasks by way of distributing them to the computers linked by internet as opposed to tackling one big problem and dividing it up to the computers. In addition, it is easy to implement, working with low-bandwidth and different kinds of

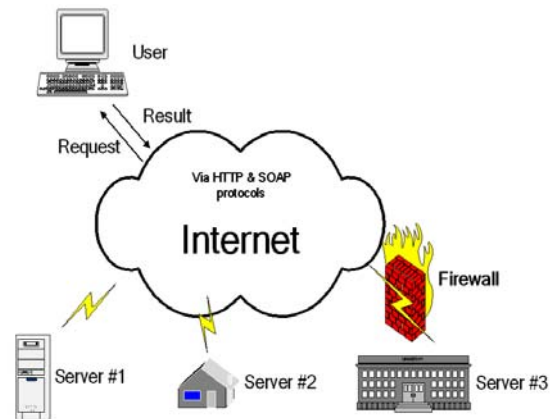

Fig. 1. Internet web service

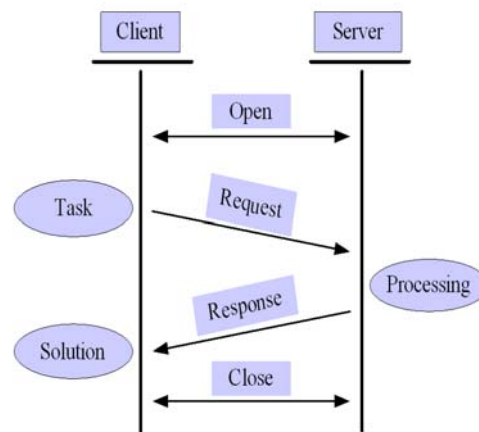

Fig. 2. Communication procedure for calling server-side web service

computers.

The proposed system is programmed using Microsoft's .NET solution [10]. Since Microsoft's .NET is capsulated for SOAP, HTTP, and SML as well, it is not necessary that the programmer deal with those protocols. Fig. 2 diagrams the communication between the client and the server. The data flow is driven by the XML format and HTTP, and SOAP protocol. As shown in Fig. 2, as soon as the web service of a server is triggered, a FEA program is invoked to do a assigned task. The results will, then, be read by the web service

routine and sent back to the client. For implementation of the distributed computing system, the existing finite element analysis programs are installed in each server without any modification for this purpose.

2.2 Static and Dynamic Load Balancing

A Load balancing mechanism for distributed or parallel computing is needed because the total number of tasks should be done is larger than the number of connected servers. It is simple method that the client distributes the same amount of tasks to each processor regardless of the network and server load status. It is called a static load balancing. The scheme of the static load balancing mechanism is shown in Fig. 3, and the procedure is as follows.

- Step 1: An main program such as stochastic optimization creates multiple number of tasks.
- Step 2: The task manager built in a client divides up the tasks according to the number of the connected servers.
- Step 3: The divided tasks are distributed to each server through SOAP.
- Step 4: Each server generates the results for the received tasks using an invoked program.
- Step 5: The results are sent back to the client.
- Step 6: If necessary, one can go back to the step 1.

The static load balancing mechanism is not efficient because of no consideration of the server speed and load status, although it is easier to implement. If there is a server which has low performance, a overall system efficiency become downgraded. Therefore, the dynamic load balancing mechanism is established in this paper. In the dynamic load balancing method, the task manager in the client distributes tasks to the servers according to the network and server load status. Therefore, the dynamic load balancing mechanism will be efficient method, although it is more complicated to set up. The scheme of the dynamic load balancing mechanism is shown in Fig. 4, and the procedure is as follows.

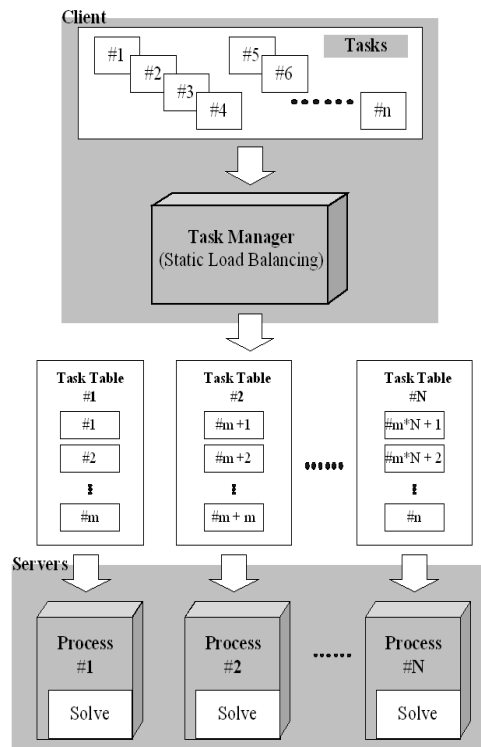

Fig. 3. Static load balancing

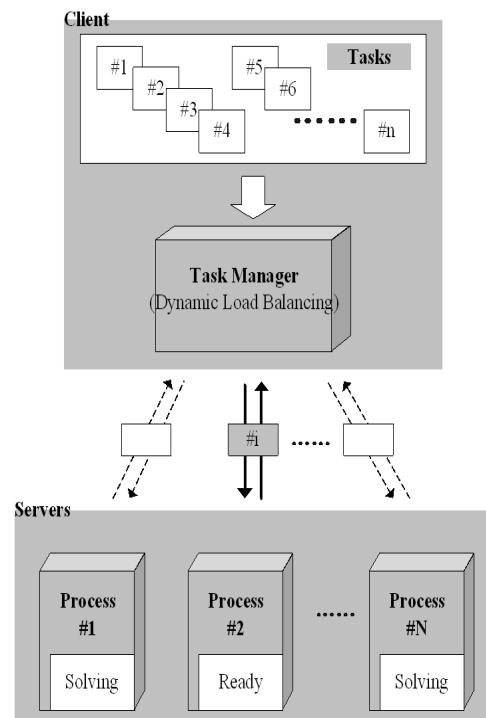

Fig. 4. Dynamic load balancing

- Step 1: Multiple number of tasks are created.
- Step 2: The task manager built in a client identifies an unresolved task and sends it to a server that is ready to solve.
- Step 3: The step 2 repeats itself until there is no server available.
- Step 4: The step 2 resumes when any one of the servers completes a task and becomes available again.
- Step 5: The step 4 repeats itself until all the tasks are completed.

2.3 FEA-based optimization

The FEA-based optimization uses a FEA(finite element analysis) simulation for the evaluation of the objective function and the constraints of the optimization problem. Therefore, many hundreds or thousands of FEA simulations during the optimal solution approaches cause very excessive execution time. To resolve this problem, the distributed computing technique using internet web service is used in this paper.

The combination of optimization module, task manager module and FEA module using internet web service is shown in Fig. 5. The optimization module and the task manager module is executed in the client computer and the FEA module are executed to calculate the objective function in several servers. An main program such as stochastic optimization creates multiple number of tasks. And the task manager built in a client divides up the tasks to servers connected. Therefore, the total execution time during the optimization can be decreased according to the number of connected servers.

2.4 Experimental Test

For the experimental test, six PC's from one lab were used as the web service servers. A PC from another nearby lab was used as the client. In order to study the performance of the proposed internet distributed computing, the well-known mathematical benchmark problem based on the Rosenbrock function is used. The 4-dimensional Rosenbrock function is defined in Equation (1). Its minimum value is known to be 0 for all $x_i=1$.

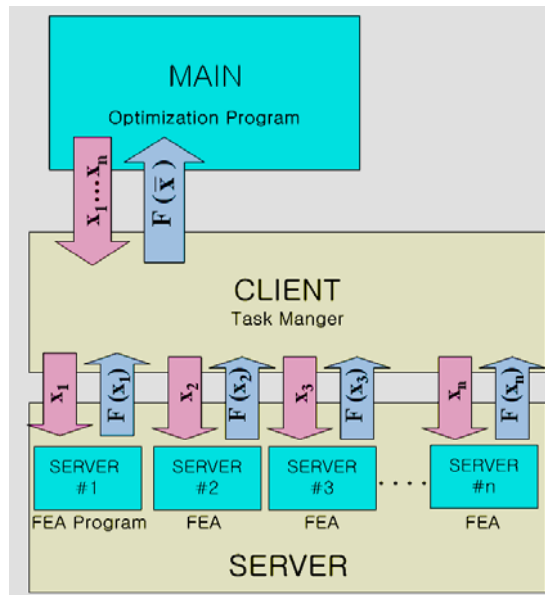
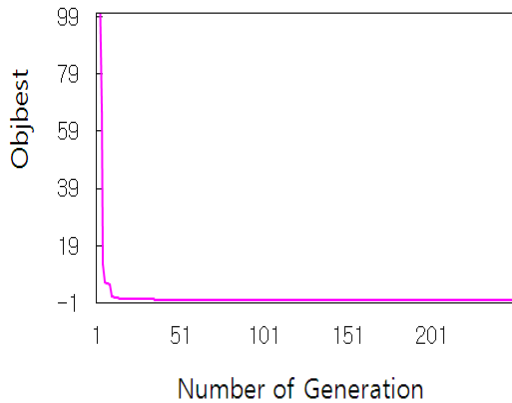

Fig. 5. The combination of optimization module, task manager and FEA module using web service

$$\begin{aligned}
 F_4(x) = & 100(x_2 - x_1^2)^2 + (1 - x_1)^2 \\
 & + 90(x_4 - x_3^2)^2 + (1 - x_3)^2 + 10.1[(x_2 - 1)^2 \\
 & + (x_4 - 1)^2] + 19.8(x_2 - 1)(x_4 - 1) \\
 ,where & -10 \leq x_1, x_2, x_3, x_4 \leq 10 \quad (1)
 \end{aligned}$$

As explained above section, genetic algorithm is used as optimization technique in this paper. For GA, the number of individuals in population is 60 and the maximum number of generation is 250. To emulate the conditions of real engineering problems which use FEA to calculate the objective functions, the evaluation time of the objective function was intentionally increased to three seconds.

Fig. 6 shows the convergence characteristic when the number of servers linked is three. It shows that the proposed method using web service perform the optimization well. Fig. 7 shows that the overall execution time during the optimization decreases according to the number of connected servers. Because of the additional time such as the data exchange time through internet, the internet distributed computing takes longer time than ideal case. The execution time for ideal case is defined as the running time on a single processor divided by the number of connected servers. It is an imaginary time.



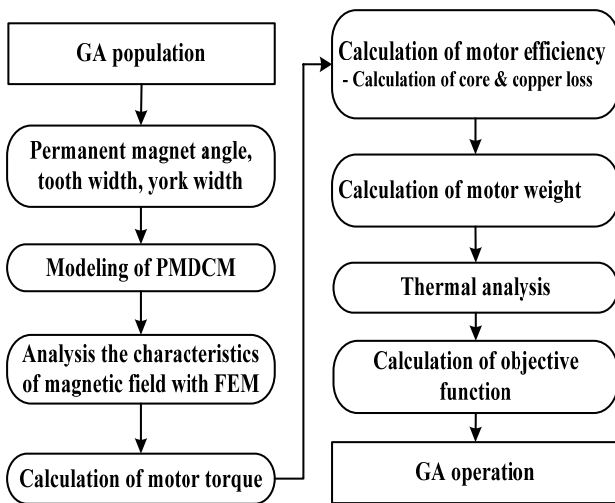

Fig. 8. Motor characteristics calculation using FEA

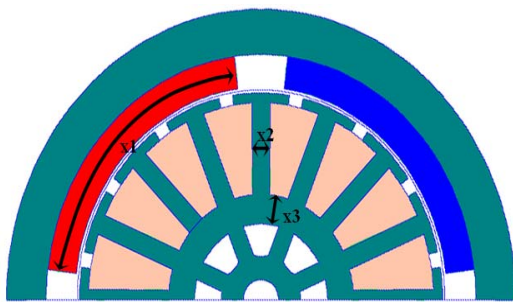

Fig. 9. Cross-section of PMDCM

As stated at section A, the aims of DC motor design for automotive are high rated torque, high efficiency, low motor weight and so on. In single objective optimization problem, the most important criterion is selected as objective function and other criteria are used as constraints. We select rated torque or efficiency of motor as main objective function. For example, the efficiency is selected as objective and others are selected as constraints in case of the efficiency maximization.

In Fig. 10 and Table 2, the results of FEA-based optimization of PMDCM are shown. In case of the torque maximization, armature tooth width is increased and the area of armature slot is decreased. It means that the current density of rotor winding is high and its temperature is also high. In case of the efficiency maximization, it has opposite result to the torque maximization. Fig. 11 shows temperature distribution of PMDCM obtained from

Table 2. Comparison between Single objective Optimization

	Design variables			Torq. [kg -cm]	Eff. [%]	Weight [kg]	Temp. [°C]
	x1 [deg]	x2 [mm]	x3 [mm]				
Original Model	82.00	3.60	19.00	8.44	71.4	0.730	70.0
Torque max.	75.81	4.04	18.16	9.25	70.1	0.730	78.1
Eff. max.	75.84	2.14	21.99	8.40	76.8	0.703	60.4

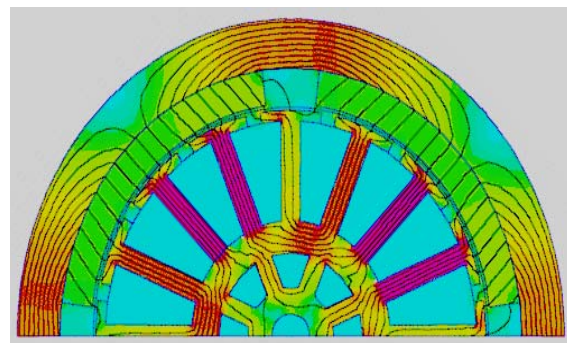

(a) Torque maximization

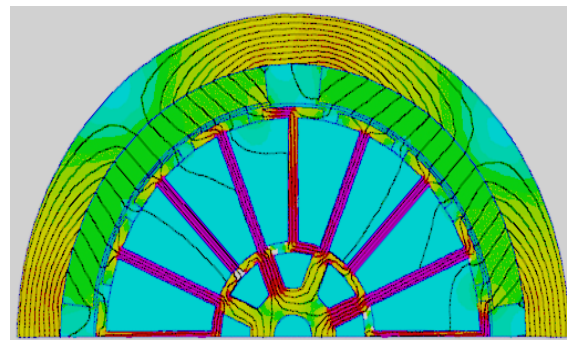

(b) Efficiency maximization

Fig. 10. Single objective optimization result

the thermal field analysis. Fig. 12 shows the convergence characteristics during the optimization approach. It shows that the proposed method can be used to the real world optimization problem such as the motor optimal design.

The speed-up factors for the proposed FEA-based optimization using internet distributed computing are shown in Table 3. When one server is used, the overall time for optimization which uses the

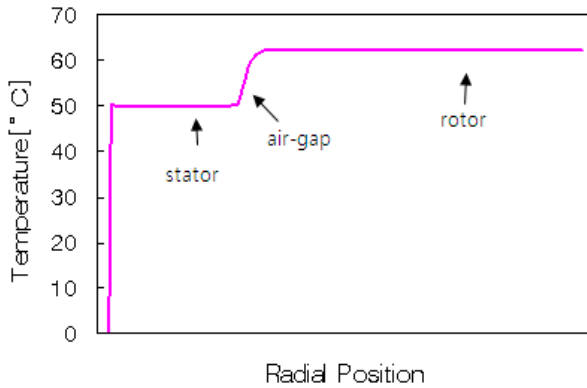

Fig. 11. Temperature distribution of motor

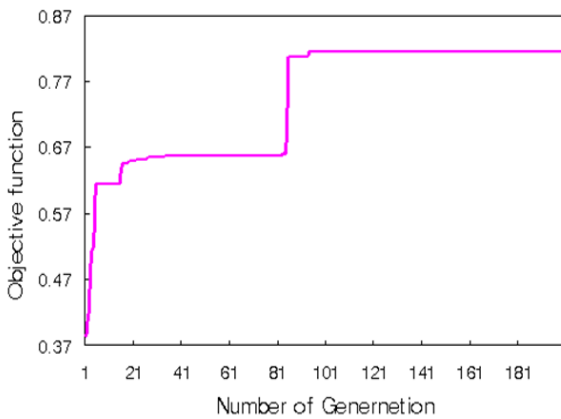

Fig. 12. The convergence characteristic of optimization of PMDCM

Table 3. Performance Evaluation of Parallelism

	Overall calculation time [min]		Speed-up factor S(10)
	1 server	10 server	
Only magnetic field analysis	1200	142	8.45
Magnetic and thermal analysis	1600	186	8.60

magnetic and the thermal field analysis together is 1,600[min]. But, when ten servers are used, the overall time for optimization is decreased to 186[min]. It is a acceptable time to motor designer. Therefore, we knows that the proposed method is very effective in reducing the overall time of FEA-based optimization.

IV. Conclusions

In this paper, the optimization technique using the internet distributed computing was successfully developed for the optimization problem that a FEA should be used for the evaluation of the objective function and the constraints. The dynamic load balancing mechanisms was also established to advance the performance of distributed computing. And we showed that the overall time for the FEA-based optimal design of PMDCM can be decreased by using the proposed method.

References

- [1] O. Arndt, et al., "A Hybrid Global and Local Search Approach Using Prdeiction in Simulation-Based Optimization", *IEEE Int. Conf. on Systems, Man and Cybernetics*, Vol. 3, Oct. 2002.
- [2] D.E.Goleberg, *Genetic Algorithms in Search, Optimization & Machine Learning*, Addison-Wesley Publishin Co., 1989.
- [3] V.F Fusco, "Electromagnetic Field Modelling Using Parallel and Distributed Processing Techniques", *Computation in Electromagnetics*, pp.13-16, April 1996.
- [4] <http://www.w3.org/2002/ws/>
- [5] M. Milenkovic, et al., "Toward Internet distributed computing", *Computer*, pp. 38-46, May 2003.
- [6] Luis F. G. Sarmenta, et al., "Bayanihan Computing .NET: Grid Computing with XML Web Services", *Proceedings of the 2nd IEEE/ACM International Symposium on Cluster Computing and the Grid*, 2002.
- [7] H.S. Choi et al., "A Distributed Computing Technique for Analysis of Electric Machines Using Internet Web Services", *Digest of CEFEC2004*, pp.124.
- [8] Peter S. Pacheco, *Parallel Programming with MPI*, San Francisco, CA: Morgan Kaufmann Publishers, Inc., 1997.
- [9] Al Geist, et al., *PVM : parallel virtual machine - a users' guide and tutorial for networked parallel computing*, The MIT Press, 1997.
- [10] S. Short, *Building XML WebServices for The*

Microsoft .NET Platform, Microsoft Press, 2002.

[11] Y.Hayashi, et al., "Development of a DC Brush Motor with 50% Weight and Volume Reduction Using an Nd-Fe-B Anisotropic Bonded Magnet", *IEEE Trans. on Magnetics*, Vol. 39, NO. 5, pp.2893-2895, 2003.

[12] S.M. Cho, J.K. Kim, H.K. Jung, and C.G. Lee, "Stress and Thermal Analysis Coupled With Field Analysis of Multilayer Buried Magnet Synchronous Machine With a Wide Speed Range", *IEEE Trans. on Magnetics*, Vol. 41, NO. 5, pp.1632-1635, 2005.

BIOGRAPHY

Lee Cheol-Gyun (Member)



1989 : BS degree in Electrical Engineering, Seoul Natil. Univ.
 1991 : MS degree in Electrical Engineering, Seoul Natil. Univ.
 1998 : PhD degree in Electrical Engineering, Seoul Natl. Univ.
 1993~1999 : Research Engineer, Hyundai Heavy Industry.

2007~ present : Professor, Department of Electrical Engineering, Dongeui University
 <Research interests> : Electric Motor Design, Optimization Method.

Choi, Hong Soon (NonMember)



1986 : BS degree in Electrical Engineering, Seoul National University (SNU).
 1988 : MS degree in Electrical Engineering, SNU.
 2000 : PhD degree in Electrical Engineering, SNU.

1988~1994 : Research Engineer, Samsung Mechatronics/Samsung SDS.
 1997~2003 : Technical director, KOMOTEK
 2003~2007 : Research professor, Sungkyunkwan University
 2007~ now : Professor, Kyungpook National University
 <Research interests> : Electric motor design, Fusion dynamics of electrical and mechanical engineering, Applied electromagnetics.