

Development of a Conduction-Cooled Superconducting Magnet System for Material Separation

Y. S. Choi*, D. L. Kim, B. S. Lee, H. S. Yang, W. M. Jung

Korea Basic Science Institute, Daejeon, Korea

Received 4 July 2008

물질분리를 위한 전도냉각형 초전도자석 시스템 개발

최연석*, 김동락, 이병섭, 양형석, 정원목

Abstract

A conduction-cooled superconducting magnet system is developed for material separation. The superconducting magnet for material separation has to be designed to have a strong magnetic field in a control volume. Since the magnetic field gradient is larger at the end rather than at the center of the magnet, we developed a design method to optimize the superconducting magnet for material separation. The safety of the superconducting magnet is evaluated, taking into account the electro-magnetic field, heat and structure. The superconducting coil is successfully wound by the wet-winding method. The superconducting coil is installed in a cryostat maintaining high vacuum, and cooled down to approximately 4 K by a two-stage GM cryocooler. The performance of the conduction-cooled superconducting magnet system is discussed with respect to the supplied current, cooling medium and cooling power of a cryocooler.

Keywords : Superconducting magnet, material separation, conduction cooling, cryocooler

I. Introduction

The conduction cooling system is an attractive design approach for superconducting magnets due to its compactness, easy and safe handling, and low running cost [1-3]. In a conduction-cooled superconducting magnet system, a 4 K Gifford-

McMahon (GM) or a pulse-tube cryocooler is employed as a heat sink to cool the magnet down to a certain operating temperature. Since the cold head of a cryocooler has a positional restriction, it should be located far from the magnet in order to avoid the degradation of cooling capacity. Also, the heat transfer is poor in the conduction cooling system because of the difficulty in thermal contact between the magnet and a cryocooler. Therefore, the cooling medium between the magnet and a cryocooler is

*Corresponding author. Fax : +82 42 865 3913
e-mail : ychoi@kbsi.re.kr

crucial in developing the superconducting magnet system.

The Korea Basic Science Institute (KBSI) has initiated the research program involving the superconducting magnet for material separation. The objective of the program is the development of compact and efficient superconducting magnet system providing high gradient magnetic field to separate magnetite as magnetic particle. This paper presents our progress on the development of the conduction-cooled superconducting magnet system with emphasis on the design, fabrication and preliminary energizing test. The associated analysis and experimental developments are also presented.

II. Design of superconducting magnet system

The magnetic field gradient should be larger at the end of the magnet in order to obtain an efficient separation. The magnetic separation is achieved by a combination of a magnetic field and a field gradient which generates a force on magnetisable particles such that paramagnetic and ferromagnetic particles move towards the higher magnetic field regions and the diamagnetic field particles move towards the lower field regions [4].

The conduction-cooled superconducting magnet system to be considered here is schematically shown in Fig. 1. The low temperature superconducting coil is wound around the magnet form which is thermally connected to the second-stage cold head of a cryocooler through the conduction plate. The room temperature bore with 52 mm diameter is located in the middle of the superconducting coil which is suspended by four gravitational supports. The binary current lead, a series combination of a normal conductor in the high-temperature section and an HTS conductor in the low-temperature section, is employed for this system. The entire cold part is covered by a thermal shield and wrapped with

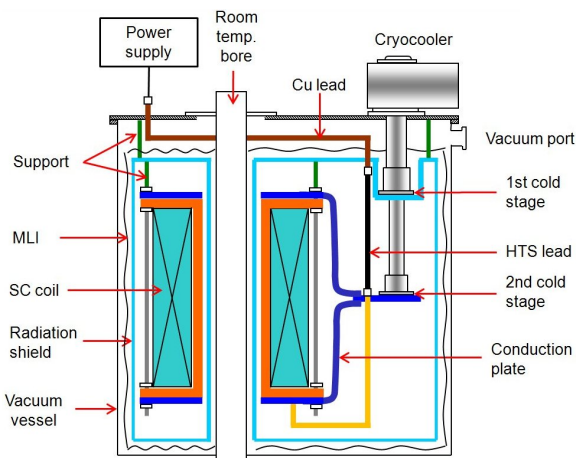

Fig. 1. Schematic of conduction-cooled superconducting magnet system.

Table 1. Design parameters of a conduction-cooled superconducting magnet.

	Parameter	Unit	Description
Superconducting wire	Material	-	NbTi
	Diameter	mm	0.93
	Cu/Non Cu	-	1.38
Superconducting magnet	Central field	T	3
	Inner Diameter	mm	80
	Outer Diameter	mm	103
	Length	mm	170
	Turn	-	176 × 14
	Inductance	H	0.215
	Storage energy	kJ	3.8
	Operation current	A	188

multilayer insulations to minimize the thermal radiation load. The main design parameters of a conduction-cooled magnet system are described in Table 1.

The operation of the cryocooler is limited by the magnetic field. The performance of a two-stage GM cryocooler is slightly degraded when the magnetic field is over 1 Tesla around the second-stage regenerator and the magnetic field should be lower than 500 Gauss for a stepper motor in the warm end [5]. In order to verify the performance of the cryocooler the analysis of the magnetic field in the

system is carried out and the results are plotted in Fig. 2. One of the conservative designs is that a cryocooler is directly mounted on the top of the vacuum vessel, which provides cooling to the radiation shield and 4 K superconducting magnet, as shown in Fig. 2. The magnetic fields at the second-stage regenerator and stepper motor are low enough to allow the normal performance of a cryocooler in this system.

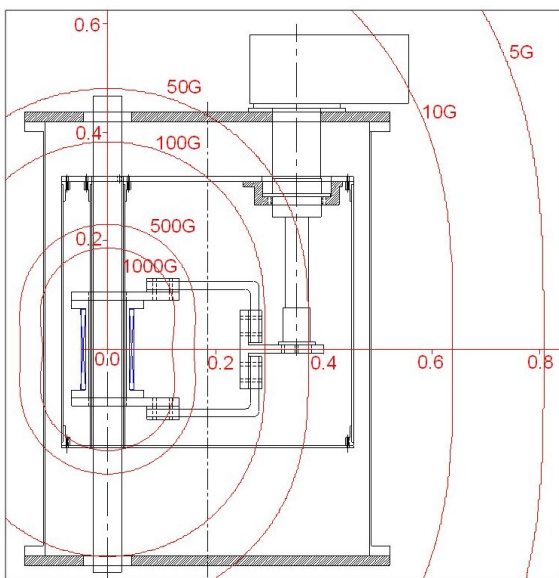

Fig. 2. Magnetic field around the superconducting magnet.

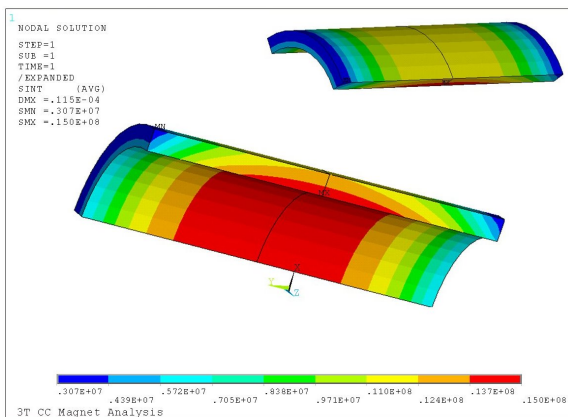

Fig. 3. Structure analysis of superconducting coil.

A parametric structure analysis is carried out in the ANSYS environment, using the linear static analysis option with three dimensional brick elements. Fig. 3 presents the result of the structure analysis considering the differential thermal contraction caused by the cool-down to the magnet operating temperature and the electro-magnetic forces on the coils when the magnet is energized at the designed current level. The maximum equivalent stress of 15 MPa occurred in the middle of coils. It is noted that the above value is far below the allowable stress of coil at 4 K (150 MPa).

III. Fabrication of magnet system

The NbTi superconducting coil is fabricated by the wet-winding method using Stycast[®]. NbTi multifilamentary composite superconducting wire ($I_c = 870$ A at 3 T and 4.2 K) of 0.93 mm diameter is wound on the copper form which has a 1 mm wide slot along the axis to reduce the eddy current losses during magnet energization. The stainless steel wire of 1 mm diameter is employed to support the electro-magnetic force in the coil. The copper form is thermally connected to the second-stage cold head of a cryocooler by flexible tinned copper braids protecting the cold head from thermal contraction during cool-down process. Cryogenic thermal greases or an indium sheet was applied between the copper form and the cold head of cryocooler as a thermal contact medium, ensuring maximum thermal conductance [6]. A copper thermal shield was suspended at the top plate of cryostat with gravitational supports made of threaded G10 rod, and attached to the first-stage cold head.

The temperatures in the magnet system are measured with platinum resistance thermometers for the first stage and Cernox[™] for the second stage at a number of locations as indicated in Fig. 4. At the initial phase of the testing, the cryostat was pumped

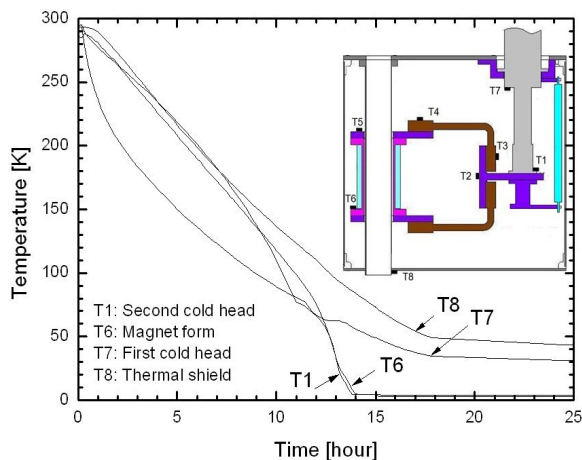

Fig. 4. Temperatures of superconducting magnet system after turning on a cryocooler and the position of temperature sensors.

down to the range of 5×10^{-3} Torr and then it was cooled down to liquid helium temperature by the cooling plate connected to the cryocooler. Once the superconducting coil was cooled down, current was supplied by a magnet power supply and magnetic field at the center of coils is measured using a gaussmeter.

IV. Magnet energization

Fig. 4 presents the temperature history of the conduction-cooled superconducting magnet system after turning on the cryocooler. During the initial cool-down process the temperatures decreased almost at a constant rate; it took approximately 15 hours for the first-stage cold head to reach 50 K, and 14 hours for the second-stage cold head to reach 4.2 K. After 18 hours running of the cryocooler, the temperature of the superconducting magnet was stabilized, and the temperatures at the first and the second cold head were 36.4 and 3.05 K, respectively, while the temperature of the magnet was indicated 3.66 K at the bottom end plate of the superconducting magnet. The cryogenic loads in the system were derived from

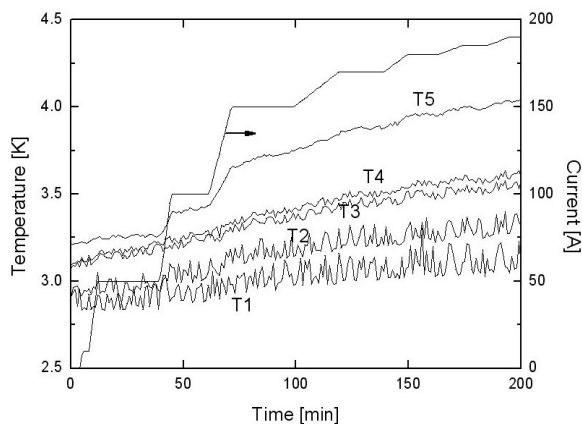

Fig. 5. Temperatures in the magnet system and energizing current with respect to the elapsed time. (Position of temperature sensors is shown in Fig. 4.)

the refrigeration capacity curves [7] of a GM cooler (Sumotomo RDK-415D), which were 39.6 and 0.4 W at the first and the second stage, respectively.

Fig. 5 shows the temperatures at the second stage and energizing current in the system with respect to the elapsed time. The current ramping rate was set to be 30 A/min. The temperatures at the second stage slightly increased with the charging current because of the heat generation at joint between the HTS lead and the superconducting wire. The magnet was trained by repeating the charging and discharging process. Finally designed current (188 A) was supplied by a magnet power supply, resulting in the generation of 3 T magnetic field. The temperature at the magnet form was below 4.1 K when the full current was supplied.

V. Concluding remarks

The conduction-cooled superconducting magnet system using a two-stage GM cryocooler was successfully designed, fabricated and tested. The superconducting magnet was cooled down to approximately 3.5 K and energized, so that the magnet system provided 3 Tesla central magnetic

field in the 52 mm room temperature bore. The material separation jig will be integrated in the room temperature bore in the near future.

Acknowledgments

This work is supported by KBSI grant T28051.

References

- [1] S. Katano, N. Minakawa, T. Hasebe and J. Sakuraba, "New cryocooler-cooled superconducting magnet: A 13.5 T high-field split-pair coil magnet for neutron scattering," *Physica B*, 385-386, 1300-1302 (2006).
- [2] H. Kitaguchi, H. Kumakura, K. Togano, K. Itoh and H. Wada, "10 T Conduction cooled Bi-2212/Ag HTS Solenoid Magnet System," *IEEE Trans. App. Supercond.*, 11, 2523-2526 (2001).
- [3] Y. Dai, L. Yan, B. Zhao, S. Song, Y. Lei and Q. Wang, "Tests on a 6 T conduction-cooled superconducting magnet," *IEEE Trans. App. Supercond.*, 16, 961-964 (2006).
- [4] J.P. Watson and I. Younas, "Superconducting discs as permanent magnets for magnetic separation," *Materials Science and Engineering*, 53, 220-224 (1998).
- [5] Y.S. Choi, D.L. Kim, T.A. Painter, W.D. Markiewicz, B.S. Lee, H.S. Yang and J.S. Yoo, "Closed-loop cryogenic cooling for a 21 T FT-ICR magnet system," *IEEE Trans. App. Supercond.*, 18, 1471-1474 (2008).
- [6] S.W. Van Sciver, M.J. Nilles and J. Pfothenaur, "Thermal and electrical contact conductance between metals at low temperature," *Proc. Space Cryogenic Workshop*, 37-48 (1984).
- [7] Product documentation, Sumitomo Co, [Online] Available: <http://www.shi.co.jp>