

Analysis of a Linkage Coil for Wireless Power Transmission by Inductive Coupling

Youn-Myoung Gimm^{1,2} · Ho-Sang Yoo¹ · Myoung-Wha Kim¹ · Jae-Sung Yoo²

Abstract

Magnetic coupling delivering wireless power in capsular endoscope(CE) is described in this paper. The characteristic of the magnetic flux linkage coil which generates the induced electromotive force(emf) under the magnetic field was analyzed. With the analyzed results, a magnetic flux linkage coil system was developed and tested. It was confirmed that the magnetic flux linkage coil system could supply more than 50 mW power at 125 kHz without changing the structure of conventional CE.

Key words : Wireless Power Transmission, Inductive Coupling, Induction Coil.

I. Introduction

CE(capsular endoscope) was developed since a new form of the gastrointestinal endoscopy was published in the journal *Nature* in May of 2000^[1]. Nowadays CE has been used usefully in evaluating the occult or obscure gastrointestinal bleeding because it is difficult to access the area like a small bowel with the conventional tethered endoscopy. CE contains a miniaturized video camera, LED, communication transmitter and battery. CE transmits high fidelity images to external recording device about 2 frames per second over the wireless.

But faster image transmission requested for better diagnosis is limited and the CE power is sometimes discharged before passing a small bowel by the cause of the battery capacity. As the CE has wide usage, users have required the diverse functions such as picking samples in the internal organs, long battery life being able to pass the small intestine and to reach the anus, and fast image transmission for diagnosing more accurately.

Current CE is not easy to fulfill the requirements because every requirement above is very closely related to the battery capacity and it is almost impossible to enlarge the battery in the limited size of CE. By this reason, the inductive coupling technology has been researched as one of alternative methods delivering the power continuously to CE. It was found that a magnetic field has very low loss inside human body in the frequency below 1 MHz^[2].

II. Power Transmission by Inductive Coupling

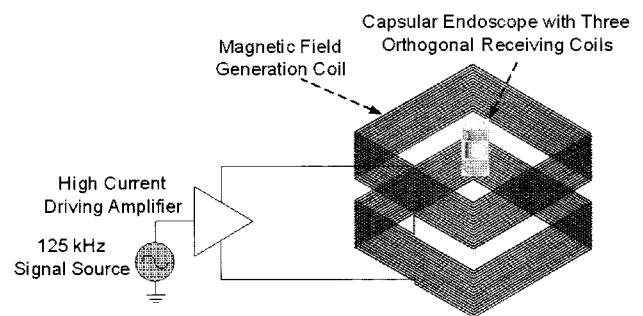

Fig. 1. Wireless power transmission system by inductive coupling.

Fig. 1 depicts wireless power transmission with inductive coupling^[3]. In Fig. 1, the source generates 125 kHz sinusoidal waveform. The source signal drives an rf amplifier which supplies sufficient current for driving the magnetic field generation coil. The current through the coil generates the high magnetic field(~ 100 A/m) inside the coil. The DC power supply needs 25 W for this field generation.

The winding wire pitch of the field generation coil should be adjusted properly to get the uniform magnetic field characteristic inside the coil. The time-varying magnetic flux penetrates the linkage coils in CE. The cross sectional area of the linkage coils in CE receives it and generates the induced electro motive force(emf). The emf is rectified and filtered and then converted to the DC output voltage. The DC voltage of the regulator in Fig. 4 operates the whole CE system.

2-1 Magnetic Field Generation System

Manuscript received January 18, 2008 ; March 3, 2008. (ID No. 20080118-002J)

¹EMF Safety Inc., Seoul, Korea.

²Graduate School of Electronics and Computer Engineering, Dankook University, Gyeonggi, Korea.

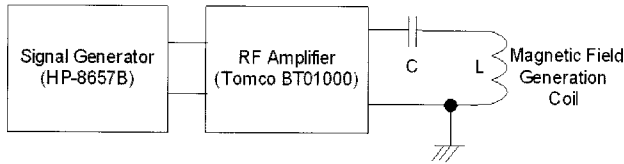

Fig. 2. 125 kHz current driving circuit for a 100 A/m magnetic field generation.

Fig. 2 is the circuit of the magnetic field generation system. It includes a signal generator and an RF power amplifier for generating the magnetic field. Magnetic field inside of the coil is easily approached to 100 A/m for the sufficient magnetic flux linkage at 125 kHz.

If the frequency is higher, we can acquire more power delivery efficiency by Faraday's electromagnetic induction law. If the frequency is even higher, the susceptance of the capsule receptor coil by intercapacitance between wound wires grows bigger, which decreases the output power efficiency. Because of these reasons, most of the wireless power transmission to the implanted medical devices utilizes frequency range between 100 kHz and a few MHz. We initially started near 100 kHz for easy signal amplification and H-field generation.

The capacitor and the magnetic field generation coil are designed to be serially resonated at 125 kHz. The resonating capacitor was used to reduce the driving voltage to the load. Without the capacitor RF amplifier could drive very small current to the coil because of the high reactance of the coil. RF power amplifier can drive high current to the magnetic field generation coil through the capacitor resonating serially with the coil, which would produce only a few ohms of resistance (real number) plus less than one ohm of reactance (imaginary number). The serial resonance also removes the harmonic signals caused by the power amplifying devices. The dimension of the magnetic field generating wood frame is 400 mm(width)×400 mm(depth)×300 mm (height), and the coil has 38 wire turns.

2-2 Magnetic Field Receiving System

Fig. 3 illustrates the conventional CE which is operated with the batteries. The space for the two batteries is Φ 9.8 mm×10 mm (length) and the magnetic field receiver (induction system) is placed in this space replacing the two batteries.

One of the issues in designing the magnetic field receiver is that the orientation of CE is in random direction. Therefore the circuit should be designed to have a magnetic linkage in any direction of CE in the unidirectional magnetic field outside. To solve this problem, three orthogonal magnetic field linkage coils wound on a

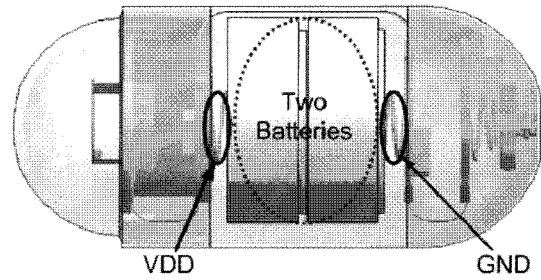

Fig. 3. Schematic of the power system of the capsular endoscope.

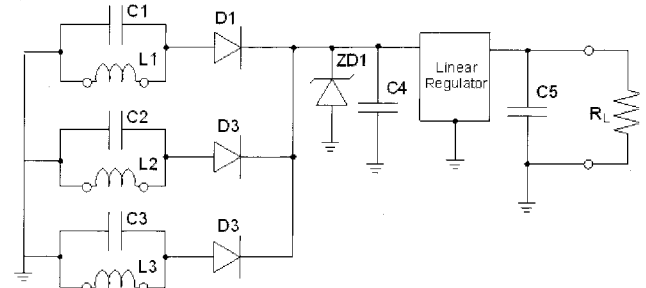

Fig. 4. The circuit of DC generation system in the capsular endoscope.

single core are used.

Fig. 4 is the circuit of the magnetic field receiving system which is coupled with the transmitted magnetic field by three orthogonally arranged receiving coils (L_1, L_2, L_3).

The linkage coils are resonating at the same frequency of the outside field (125 kHz) by being connected with the parallel capacitor (C_1, C_2, C_3) each other. The capacitances are adjusted for the resonance with the separated coils at the identical frequency. The three ac voltages are rectified by the diodes (D_1, D_2, D_3) and the highest of three rectified DC voltages is selected by diode OR circuit. The Zener diode protects the linear regulator from the over-voltage. The capacitor (C_4) converts the rectified AC voltage of the induced emf to the smooth DC voltage. The DC voltage is regulated to 3.3 VDC by the linear regulator. The output of the linear regulator is supplied to the load R_L and to the capacitor (C_5) which is used for the deletion of high frequency noise.

2-3 Human Safety Consideration to H-field Exposure

Human influence by hundreds kHz electromagnetic field is the interim region between non-thermal and thermal effect. By non-thermal effect human feels electric current flow in the body and by thermal effect human feels warmth in the body.

H-field safety guideline at 125 kHz is 12.8 A/m by ICNIRP(International organization) and 64 A/m by NRPB (Great Britain). In this experiment H-field is near around 100 A/m which is 1.6 times of NRPB guideline. Because this system is a kind of medical devices, it is usually permitted to generate the field more than the protection guideline because it gives more benefit than harm to human health.

III. Coil System for a Magnetic Flux Linkage

3-1 Design of a Linkage Coil

The core having high relative permeability is normally used to obtain higher induced emf by pulling nearby magnetic flux. The ferrite core of the linkage coil is shown in Fig. 5. The core size is Φ 9.5 mm (outermost diameter) \times 6.8 mm(top and bottom height) and the wires for three coils are wound around each axis(x, y, z).

Fig. 6 demonstrates the magnetic flux vector near and inside simulated the ferrite core computed by commer-

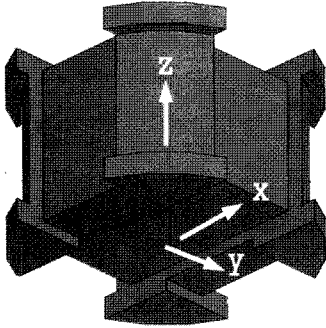

Fig. 5. The ferrite core structure for 3 flux linkage coils.

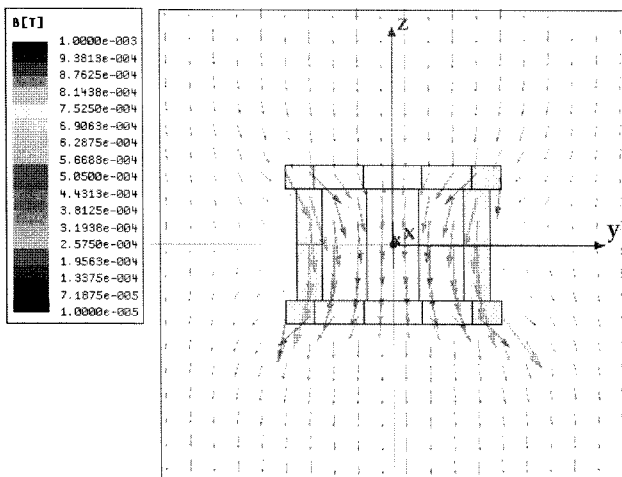
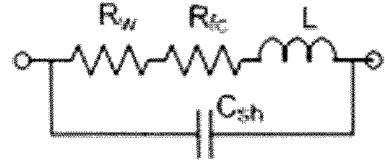
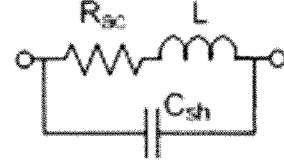

Fig. 6. Magnetic flux vector around and inside the ferrite core.



(a) Lumped parameter equivalent circuit



(b) Simplified lumped parameter equivalent circuit



(c) Equivalent series circuit of (b)

Fig. 7. The equivalent circuit model of the coil with a ferrite core.

cial Electronic Design Automation(EDA) tool(Ansoft Maxwell). It is confirmed that the ferrite core pulls the close magnetic flux and so the magnetic flux density B inside of the ferrite core increases about 4 times of B without the core if the relative permeability of the core is 1,000. If relative permeability is more than 200, B still remains almost the same value when $\mu_r=1,000$ ^[4].

The z -axis coil for a magnetic flux linkage has 56-turns in the simulation process for the intention of 4.0 Vp-p Faraday's induced emf without the parallel resonance capacitor(C_3) under the 100 A/m(rms) magnetic field environment. The wire diameter used in the linkage coil is 0.15 mm.

Fig. 7(a) is the equivalent circuit model of the coil with a ferrite core^[5]. In Fig. 7, R_w is the resistance of the winding, R_{fc} denotes the ferrite core losses which might be negligibly small, R_{ac} is the total resistance of the previous model, C_{sh} is the parasitic shunt capacitance, L is the low-frequency inductance of a coil, R_s is serial resistance and X_s is serial reactance. The parasitic shunt capacitor C_{sh} in Fig. 7(b) is 86.7 pF by Eq. (1) and is negligible at 125 kHz when it is compared with the reactance of L ($\omega L \ll 1/\omega C$). Parasitic shunt capacitance of the wire is calculated as [6]

$$C_{sh}(F) = \epsilon_o \epsilon_r \frac{2\epsilon_r \arctan \left[\frac{(-1+\sqrt{3}) \left(2\epsilon_r + \ln \frac{D_o}{D_c} \right)}{(1+\sqrt{3}) \sqrt{\ln \frac{D_o}{D_c} \left(2\epsilon_r + \ln \frac{D_o}{D_c} \right)}} \right]}{\sqrt{2\epsilon_r \ln \frac{D_o}{D_c} + \left(\ln \frac{D_o}{D_c} \right)^2}} \quad (1)$$

where ϵ_o is permittivity($=8.854 \times 10^{-12}$ F/m) in vacuum, l_t is turn length(m), ϵ_r is the dielectric constant of the enamel($=3$) used for coating a conductor, D_o is the outer diameter($=1.52 \times 10^{-4}$ m) of a wire coated by enamel, D_c is the conductor diameter($=1.12 \times 10^{-4}$ m) of a wire.

The inductance L of the coil in Fig. 7 is given by Eq. (2)^[7].

$$L = \frac{\mu_o A_e N^2}{\ell_e} \quad (2)$$

where μ_o is permeability in vacuum($=4 \pi \times 10^{-7}$ H/m), A_e is the core's effective cross sectional area in m^2 , N is the turn number of a wound wire, ℓ_e is the core's effective magnetic path length in m .

If a core is used, it is not very easy to calculate the inductance of a coil manually by Eq. (2), because the effective cross sectional area and the effective magnetic path length is variable according to the shape and the dimension of the core. Therefore we calculated the equivalent circuit impedance of a coil having a ferrite core ($\mu_r=1,000$, $\epsilon_r=12$, $\sigma=0.01$ S/m) by simulating the coil model with 3D field analysis tool(Ansoft Maxwell). The 56-turns coil model around the z-axis in Fig. 8(a) is drawn for simulation. The dimensions of the core are the same as in Fig. 5 and the wire diameter is 0.15 mm. Fig. 8(b) is the parameter values of the equivalent circuit obtained after simulation. On the basis of this result, the commercially available 15 nF capacitor is selected as the capacitance(C_3) in Fig. 4 to make resonance at 125 kHz.

3-2 Fabrication and Test of the Linkage Coil

Fig. 9 displays the fabricated three-axes linkage coils with the circuit. The average measurement values of 5 identical coils of winding around z-axis is that the

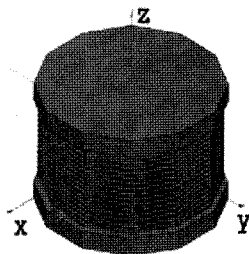

(a) The 56-turns coil drawn for simulation



(b) The parameter values of the equivalent circuit after simulation.

Fig. 8. The model and result.



Fig. 9. The fabricated DC generating system with the coils and the circuit.

inductance is 98.3 μ H, the resistance is 1.70 ohm and Q is 35.5 at 100 kHz by Instek LCR-821 whose nearest measurement frequency to 125 kHz is 100 kHz. Another one and a half turns will add quickly the inductance to near 104 μ H. Three 49, 51, 57 turns around x-axis, y-axis, z-axis are wound on the core for their inductance to be about 104 μ H at 100 kHz because the structure and dimensions of the wound core are not identical in each axis in Fig. 5.

Under the environment of 100 A/m(rms) inside the magnetic field generation coil, the measured emf of the fabricated flux linkage coil alone around z-axis is about 3.20 Vp-p. The emf of the flux linkage coil is enlarged to 9.7 Vp-p with the resonance capacitor(C_3). This emf is converted to 3.3 VDC power source for the CE system operation after rectification and regulation.

IV. Conclusion

In this paper the inductive coupling concept is described for transmitting the power continuously to capsular endoscope by wireless. The coil which can link the magnetic flux within the battery size in the conventional CE is designed. The magnetic flux flow around and inside the core is simulated. The equivalent circuit model of the coil with a ferrite core is suggested and the parameter values of the coil are derived with the commercial simulator.

On the basis of the analysis of the linkage coil, the power generating system in CE was fabricated. We confirmed that the fabricated coil system supplies more than 50 mW power at 3.3 VDC and it was possible to replace the battery consuming less than 25 mW in the conventional CE.

This research has been supported by the Intelligent Microsystem Center(IMC; <http://www.microsystem.re.kr>), which carries out one of the 21st century's Frontier R&D Projects sponsored by the Korea Ministry of Commerce, Industry and Energy.

References

- [1] G. Iddan, G. Meron, A. Glukhovsky, and P. Swain, "Wireless capsule endoscopy", *Nature*, pp. 405-417, 2000.
- [2] Youn-Myoung Gimm et al., "125 kHz magnetic field attenuation characteristics in some of the homogeneous human organs", *Electronic Proceedings of the 2007 International Symposium on Antennas and Propagation*, Niigata, Japan, pp. 430-433, Apr. 2007.
- [3] Youn-Myoung Kim et al., "Receiving coil analysis of wireless power transmission with inductive coupling", *Proceeding of 2007 Korea-Japan Microwave (KJMW) Conference*, Okinawa, Japan, pp. 117-120, Nov. 2007.
- [4] Youn-Myoung Gimm et al., "Magnetic field analysis of a ferrite core in high frequency magnetic field environment", *KEES Proceeding of M/W & RF Propagation Workshop*, Seoul, Korea, vol. 30, pp. 549-552, May 2007.
- [5] M. Bartoli, A. Reatti, and M. K. Kazimierczuk, "High-frequency models of ferrite core inductors", *IECON94 20th International Conference*, vol. 3, pp. 1670-1675, 1994.
- [6] Antonio Massarini, Marian K. Kazimierczuk, "Self-capacitance of inductors", *IEEE Trans. Power Elect.*, vol. 12, no. 4, pp. 671-676, 1997.
- [7] George G. Orenchak, "Measuring soft ferrite core properties", *Electrical Manufacturing & Coil Winding Conference*, pp. 497-500, Sep. 1995.

Yoon-Myoung Gimm

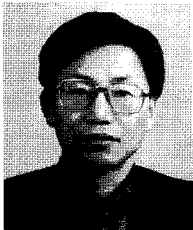

received the B.E. degree in electronics engineering from the Seoul National University, Seoul, Korea in 1975, and the M.E. and Ph.D. degrees in electrical and electronics engineering from Korea Advanced Institute of Science and Technology (KAIST) in 1977 and 1990, respectively. Since 1980 he has been with the department of electronics engineering, Dankook University, Yong-In, Korea, where he is now a professor in the school of electronics and electrical engineering. He is also a CEO of EMF Safety Inc. since 2000. His research interests are the electromagnetic field measurements related with the biological effect.

Ho-Sang Yoo



received the B.E. degree in electronics engineering from the Dankook University, Seoul, Korea in 1991, and the M.E. degree in electronics engineering from Dankook Graduate School in 1993, and Ph. D. degree in electronics and computer engineering from Dankook Graduate School in 2007. He worked in the R&D center of Dongwon Systems, GT&T and EMF Safety for 15 years until 2007. He was awarded the minister prize of information and communication in 5th new radio technology award from RAPA in Korea. He has worked as a director of the R&D center in Alphawave since 2008 and has been a member of Korea Electromagnetic Engineering Society since 2003. His research interests are the RF communication system, the electromagnetic field measurements related with the biological effect.

Myoung-Hwa Kim



received the B.E. degree in electronics engineering from the Korean Educational Development Institute, Seoul, Korea in 2005 and she is now a student for master degree in Graduate School of Communication and Information of Dankook University. Her research interests are the EMI/EMC and electromagnetic field measurements related with the biological effect.

Jae-Sung Yoo

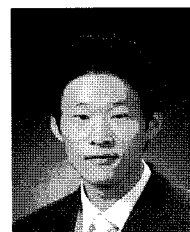

received the B.E. degree in electronics engineering from the Dankook University, Seoul, Korea in 2006, and he is now studying for master degree in the Graduate School of Dankook University. His research interests are the EMI/EMC and electromagnetic field measurements related with the biological effect.