

실리카겔 공극에서의 이산화탄소 및 메탄 하이드레이트 상평형 측정 및 열역학적 예측

강성필*

Phase Equilibrium of the Carbon Dioxide and Methane Hydrate in Silica Gel Pores and Thermodynamic Prediction

Seong-Pil Kang*

Abstract Hydrate phase equilibrium for the binary CO₂+water and CH₄+water mixtures in silica gel pore of nominal 6, 30, and 100 nm were measured and compared with the calculated results based on van der Waals and Platteeuw model. At a specific temperature three-phase hydrate-water-vapor (HLV) equilibrium curves for pore hydrates were shifted to the higher-pressure condition depending on pore sizes when compared with those of bulk hydrates. Notably, hydrate phase equilibria for the case of 100 nominal nm pore size were nearly identical with those of bulk hydrates. The activities of water in porous silica gels were modified to account for capillary effect, and the calculation results were generally in good agreement with the experimental data.

Key words 가스하이드레이트(gas hydrate), 평형(equilibrium), 실리카겔(silica gels), 공극(pores), 이산화탄소(carbon dioxide), 메탄(methane)

* Gasification Research Center, Korea Institute of Energy Research (KIER)
 ■E-mail : spkang@kier.re.kr ■Tel : (042)860-3475 ■Fax : (042)860-3097

Nomenclature

f : fugacity, MPa
 R : gas constant, J/mol · K
 θ : contact angle, °, fraction of cavities
 ν : number of cavities of type m per water molecule in the hydrate phase
 $\Delta\mu$: chemical potential difference between the empty hydrate and filled hydrate phase

subscrip

V : vapor L : liquid
 H : hydrate MT : empty
 I : ice fus : fusion(melting or dissociation)
 w : water

1. Introduction

Clathrate hydrates (or gas hydrates) are a kind of inclusion compounds which are formed by physically stable interactions between water and relatively small guest molecules entrapped in the cavities of a three dimensional lattice-like structure built by water molecules under low temperature and high pressure conditions. These kind of non-stoichiometric crystalline compounds are divided into three distinct structures, I, II and H, which differ in cavity size and shape. CO₂ and CH₄ are known to form the structure I hydrate.

In spite of the importance for understanding the phase behavior of gas hydrates in porous media of sediments in deep ocean, only a few works have been reported in the literature. Handa and Stupin⁽¹⁾ investigated the first work of the effect of porous media on equilibrium pressures of CH₄ and C₃H₈ hydrates. They showed that the equilibrium pressures of the corresponding gas hydrates in silica gel pores were higher than those of the bulk hydrates. Uchida *et al.*⁽²⁾ determined the equilibrium pressures of CH₄, C₃H₈, and CO₂ hydrates in porous glasses. In a series of publications, Wilder *et al.*⁽³⁾, Seshadri *et al.*⁽⁴⁾, Smith *et al.*⁽⁵⁾, and Zhang *et al.*⁽⁶⁾, used a conceptual model to explain the hydrate equilibria in porous media, adopting a pore size distribution. Some workers have modified the thermodynamic model for bulk hydrate originally developed by van der Waals and Platteeuw (vdWP) to elucidate the effect of pore size on hydrate equilibrium conditions.

Whereas most of works on hydrate equilibrium conditions in porous media have been concentrated on simulating the circumstances of simplified sediments, the authors have an interest in employing gas hydrate in porous media as a gas storage method. Porous materials such as silica gels have a great amount of internal volumes to enable to bear waters molecules inside, which can be used for hydrate formation. Seo *et al.*⁽⁷⁾ showed a remarkable result on rapid CO₂ hydrate formation in porous silica gels. Their result showed that the confined water does not hinder gas transport into silica pores, which is the typical phenomenon in bulk hydrates thus gas molecules can easily contact and diffuse into pores through the layer of bound water to participate in the formation of hydrate in pores.

The aim of the present work is to understand the fundamental phase behavior and structure details of pore hydrates for method to store gas molecules in porous media by using gas hydrate formation.

2. Experimental Procedure

CO₂ gas used for the present study was supplied by World Gas (Korea) and had a stated purity of 99.9 mol%. CH₄ gas with a minimum purity of 99.995 mol% was supplied by Matheson Gas Products Co. and deionized water produced by a Millipore purifier was used. As a porous material, spherical silica gels of nominal pore diameter 6 nm, 30 nm, and 100 nm were selected and purchased from Aldrich (6 nm) and Silicycle (30 nm and 100 nm), respectively. All the materials were used without further treatment. The properties of silica gels having three different pore diameters were measure by nitrogen adsorption/desorption experiments with ASAP 2400 (Micrometrics) and listed in Table 1.

Table 1. Physical Properties of Silica Gel Samples

Sample Name	6nm SG	30nm SG	100nm SG
mean particle diameter(μm)	150 to 250	40 to 75	40 to 75
mean pore diameter(nm)	5.51	30.1	94.5
specific pore volume (m^3/kg)	8.4×10^{-4}	8.4×10^{-4}	8.3×10^{-4}
specific surface area (m^2/kg)	586×10^3	94.9×10^3	42.4×10^3

The used silica gels were first dried at 373 K for 24 h before water sorption. The, the pore saturated silica gels were prepared by placing these dried silica gels in a

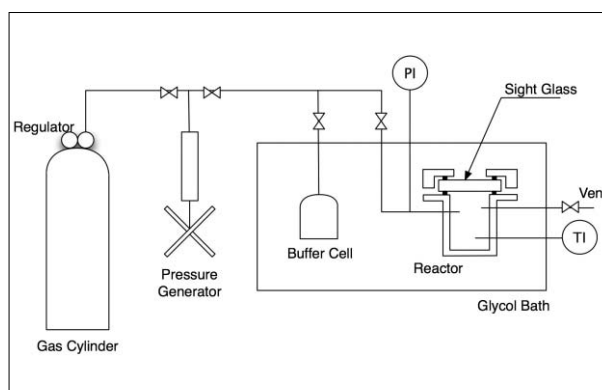

Fig. 1 Schematic illustration of the equilibrium experimental setup

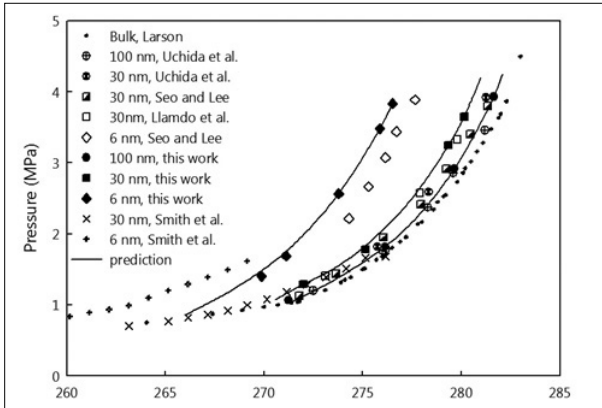

Fig. 2 Hydrate phase equilibria of the binary CO₂+water mixtures in silica gel pores

desiccator containing degassed water, evacuating the desiccator, and allowing more than 3days in order to establish the solid–vapor equilibrium. The total amount of sorbed water in the silica gel pores was confirmed by measuring the mass of silica gels before and after saturation and was found to be almost identical with the pore volume of each silica gel. The pressure–temperature dissociation equilibrium curves for CO₂ and CH₄ hydrates formed in silica gel pores were determined using a high–pressure cell with accompanying experimental setup (Fig. 1). The apparatus was specifically constructed to measure accurately the hydrate dissociation pressures and temperatures. The experimental setup consisted of an equilibrium reactor and a buffer cell, both made of 316 stainless steel (maximum working pressure of 15 MPa).

The equilibrium reactor had an internal volume of about 350 cm³. The experiment for hydrate phase equilibrium measurements starts with charging the equilibrium cell with about 250 cm³ of silica gels containing pore water. After the cell was pressurized to a desired pressure with CO₂ or CH₄, the whole main system was slowly cooled to 263 K. When pressure depression owing to hydrate formation reached a steady–state condition, the cell temperature was increased at a rate of about 0.1 K/h. The nucleation and dissociation steps were repeated at least two times in

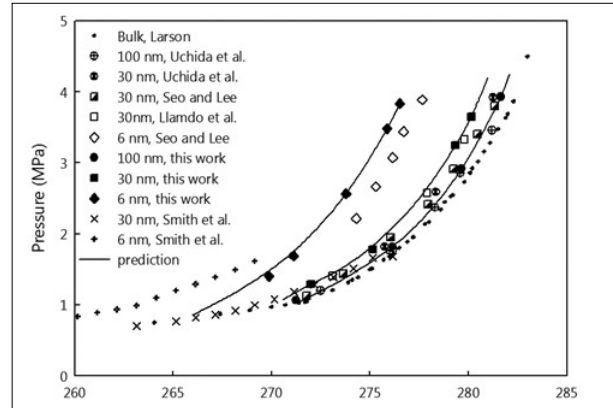

Fig. 3 Hydrate phase equilibria of the binary CH₄+water mixtures in silica gel pores

order to reduce hysteresis phenomenon. While the experiment was performed, the temperature and pressure of the equilibrium cell was gathered by data acquisition system. The equilibrium pressure and temperature of three phases (HLV) were determined by tracing the PT profiles from hydrate formation to dissociation.

3. Thermodynamic Model

The equilibrium criteria of the hydrate–forming mixture (CO₂+water or CH₄+water) are based on the equality of fugacities of the specified component *i* in all phases which coexist simultaneously

$$f_i^H = f_i^L = f_i^V (=f_i^I) \quad (1)$$

where H stands for the hydrate phase, L for the water–rich liquid phase, V for the vapor phase, and I for the ice phase. From the author's previous works, the final equilibrium equation is derived as follows

$$\frac{\Delta \mu_w^\circ}{RT_0} - \int_{T_0}^T \frac{\Delta h_w^{MT-I} + \Delta h_w^{fus}}{RT^2} dT + \int_0^P \frac{\Delta v_w^{MT-I} + \Delta v_w^{fus}}{RT} dP + \sum_m \frac{T_0}{m} v_m \ln(1 - \sum_j \theta_m) - \ln(\gamma_w x_w) \quad (2)$$

In the present study, it is assumed that the pores of silica gels were completely saturated with water, and thus, in the HLV equilibrium, the pores are completely filled with liquid water and hydrate in equilibrium with bulk gas. The decrease of water activity in porous silica gels mainly due to capillary effect occurring by the presence of geometrical constraints, that a cylindrical pore and solid-phase dissociation (ice melting or hydrate dissociation) are assumed, can be modified, thus the last term of (2) is expressed as(9),(10)

$$\ln a_{\omega}^{pore} = \ln a(\gamma_{\omega} x_{\omega}) - \frac{Fv_{L\omega}HW}{\mathcal{R}T} \cos\theta \quad (3)$$

where v_L is the molar volume of pure water, θ is the wetting angle between water and hydrate phase, HW is the interfacial tension between hydrate and water phase, r is the pore radius, and F is the shape factor of the hydrate-water interfacial curvature. Solving (2) and (3) will determine the three-phase HLV equilibrium conditions for pores of radius r . The right side of (3) moves the equilibrium conditions to higher pressures and lower temperatures when compared with those of bulk hydrates.

4. Results and Discussion

Three-phase HLV equilibria of CO_2 and CH_4 hydrates in silica gel pores with nominal pore diameters of 6, 30, and 100 nm were measured. Model prediction results were also presented along with the experimental data in Fig. 2 and 3 for CO_2 +water and CH_4 +water mixture, respectively. All HLV equilibrium lines of each hydrate in silica gel

pores were shifted to the lower temperature and higher pressure region when compared with those of bulk hydrates. This inhibition behavior can appear similarly for melting point depression of ice in small pores. As clearly seen in figures, the measured data

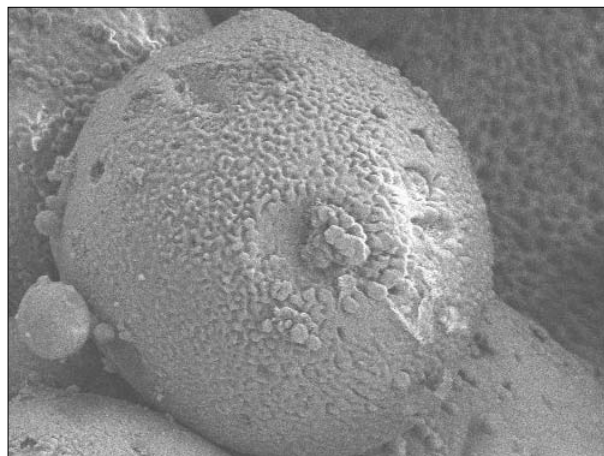

Fig. 4 Field-emission scanning electron image of the silica gel containing gas hydrate in pores

showed in a good agreement with those of Anderson *et al.*⁽¹¹⁾ previously reported data but largely deviated from those of Smith *et al.* In case of 30 and 100 nm silica gel pores, the measured equilibrium pressures in this study was generally in agreement with those of Seo *et al.*, and Uchida *et al.* even though their experimental method is controversial. On the other hand, the difference of the equilibrium dissociation pressures between this study and Seo *et al.* was significant at smaller silica gel pore of 6 nm nominal pore diameter. It was also shown that the equilibrium pressure shifts were found to be larger as the pore size decreases at constant temperature, and the equilibrium pressure shifts become larger as temperature increases at constant pore size.

In silica gel pores, the chemical potential of components had been affected by a consequence of molecular interactions at the hydrophilic pore wall surfaces, and the energy required maintaining capillary equilibrium. Partial ordering and bonding of water molecules with pore surfaces let down water activity, therefore decrease of water activity needs higher pressure at a specific temperature and lower temperature. This phenomenon is also observed in the mixtures containing inhibitors such as salts and alcohols which cause a depression in the freezing point of water thereby reducing its activity.

Even we carefully introduced water to silica gel pores, a significant part of water in the wall of confined spaces would be existed as bound water, All of the To get a solution of predicted equilibrium pressure to (2) at a proposed initial guessed temperature, the only remaining property is now the interfacial tension between hydrate and liquid water, σ_{HW} . Uchida et al. presented the values of σ_{HW} from fitting their experimental data by the Gibbs-Thompson equation for CO₂ and CH₄ hydrates, but the estimated values (0.017 J/m² for CH₄ and 0.014 J/m² for CO₂ hydrate) did not produce good agreement to experimental data. Recently, Anderson *et al.* presented more sophisticatedly estimated values from experimental data for hydrate dissociation condition (0.032 J/m² for CH₄ and 0.030 J/m² for CO₂ hydrate). We employed our previously used ones including the latter two interfacial tension values. All of the parameter values in this model were given in the previous papers.

To confirm the formation of gas hydrate in silica gel pores, the FE-SEM was adopted, and shown in Fig. 4. Ex situ FE-SEM observation of porous silica gel particle shows the wave-like surface, which is guessed owing to hydrate formation in pores. It seems that the confined water among spherical silica gel particles does not occur, although water added to silica gels were controlled not to exceed the adequately absorbed only to inside the pores of particles. This could be a great merit to handle hydrate easily when it is applied to gas transport/storage method. Comparing to bulk hydrate, it seems easier to handle particles than sticky and massive hydrates. Further research will be continued to investigate this method.

Acknowledgement

This work was supported by Ministry of Commerce, Industry and Energy (MOCIE) through Electric Power

Industry Technology Evaluation & Planning Center (ETEP).

References

- (1) Handa YP, Stupin D, Thermodynamic properties and dissociation characteristics of methane and propane hydrates in 70-Å-radius silica gel pores. *Journal of Physical Chemistry* 1992;22:1111-1117
- (2) Uchida T, Ebinuma T, Ishizaki T, Dissociation condition measurements of methane hydrate in confined small pores of porous glass. *Journal of Physical Chemistry B* 1999;103:3659-3662
- (3) Wilder JW, Seshadri K, Smith DH, Modeling hydrate formation in media with broad pore size distribution. *Langmuir* 2001;17:6729-6735
- (4) Seshadri K, Wilder JW, Smith DH, Measurements of equilibrium pressures and temperatures for propane hydrate in silica gels with different pore-size distributions. *Journal of Physical Chemistry B* 2001;105:2627-2631
- (5) Smith DH, Wilder JW, Seshadri K, Methane hydrate equilibria in silica gels with broad pore-size distributions. *AIChE Journal* 2002;48:393-400
- (6) Zhang W, Wilder JW, Smith DH, Interpretation of ethane hydrate equilibrium data for porous media involving hydrate-ice equilibria. *AIChE Journal* 2002;48:2324-2331
- (7) Seo YT, Moudrakovski IL, Ripmeester JA, Lee JW, Lee H, Efficient recovery of CO₂ from flue gas by clathrate formation in porous silica gels. *Environmental Science and Technology* 2005;39:2315-2319
- (8) Kang SP, Lee H, Recovery of CO₂ from flue gas using gas hydrate: thermodynamic verification through phase equilibrium measurements. *Environmental Science and Technology* 2000;34:4397-4400
- (9) Henry P, Thomas M, Clennell MB, Formation of natural gas hydrates in marine sediments 2. thermodynamic

calculations of stability conditions in porous sediments.
Journal of Geophysics Research B 1999:104:22005-23022

- [10] Clarke MA, Pooladi-Darvish M, Bishnoi PR, A method to predict equilibrium conditions of gas hydrate formation in porous media. Industrial and Engineering Chemistry Research 1999:39:2485-2490

강성필

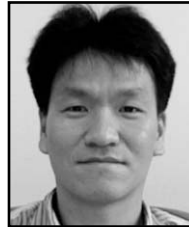

1994년 고려대학교 화학공학과 공학사
1996년 한국과학기술원 화학공학과 공학석사
2000년 한국과학기술원 화학공학과 공학박사

현재 한국에너지기술연구원 가스화연구센터 선임연구원
(E-mail : spkang@kier.re.kr)
