

A Study on the Application of RFID to Container Terminals

Sung-Soo Kim · Myoun-Soo Lee* · Yong-Seok Song** · Ki-Chan Nam*** · Kyu-Suk Kwak****

** Graduate School of Logistics Korea Maritime University, Busan 606-791, Korea*

*** Profesor, College of Commerce & Economics, Department of Distribution Management Dong-Eui University, Busan, 614-714, Korea*

**** Profesor, Department of Logistics Korea Maritime University, Busan, 606-791, Korea*

**** Profesor, Department of Logistics Korea Maritime University, Busan, 606-791, Korea*

Abstract : The container terminals in Korea usually adopts both the bar code and the image recognition systems at the gate complex to capture necessary information on containers passing through the gate. With the rapid advancement of Information Technology(IT) these systems, however, seem to make the user not satisfied due to the inherent limitations such as the long process time taken, low rate of recognition etc., This paper, therefore, examines the adoption of Radio Frequency Identification (RFID) technology to container terminals, and tried to get some implication for the way to improve the productivity of the terminal. The results imply that some improvement in the gate and storage yard operation is feasible by the benefit of using the information of vehicles and containers collected in advance by RFID technology.

Key words : *RFID, RFID tag, Container yard, Gate, Tollgate, Application*

1. Introduction

It seems that the level of information systems and usage in Korean container terminals are higher than overseas ones in general, as the advanced level of domestic Information Technology(IT) has been steering the development. The container terminals have been dependent on the traffic prediction through the past data(Yoo, 2004) and the information transmitted via EDI(Electronic Data Interchange) in advance to plan the operation of the terminals, and the whole process of terminal operation is computerized(Lee, 2003).

One of the major limitations faced by Korean container terminals is the insufficient storage space. In average the capacity of staking yard is around 60 to 70 percent level of quay handling capacity resulting in depending on many off-dock container yards(ODCY) to acquire an additional storage space(Ministry of Commerce, Resource and Energy, 2004). In such situation the critical point for the terminal operators is how to increase the capacity of existing storage space by adopting a new technology. Particularly, the recent emerging technology, RFID, is significantly attracted to compensate the limitations of the existing systems such as bar code or image recognition. It seems to be a general belief that RFID can replace the bar code or the image recognition systems, and it can contribute to improve the efficiency and productivity of terminal operation.

In this paper, therefore, we examine the way to improve the efficiency and the productivity of container terminal by adopting RFID, particularly with respect to the gate complex and the storage yard. For this the flow of the information at the existing container terminals is illustrated followed by the discussion of the practice and problem of the operation of both the gate and the storage yard in container terminals. Then, the concept and the application aspect of RFID are stated with the implication for the improvement of container terminals.

2. The Practice of Container Terminal Operation

2.1 The Flow of Information

In Korea KL-Net(Korea Logistics Network Corporation) is the unique body commissioned to transmit various documents for import and export containers such as 'Bay Plan', 'Container Loading List', 'Booking Prospect for Terminal', 'Terminal Gate Log', 'Pick-up/Arrival Pre-Notification' etc., to container terminals, forwarders, shippers and shipping companies via EDI(Lee, 2003). This means that prior to the physical movement of containers the corresponded information is distributed to the relevant bodied.

In the case of export containers the shipping company will transmit the 'booking prospect' containing information on containers to be loaded on board a designated vessel to

* Corresponding Author : Eun-bang Lee, eunbang@hhu.ac.kr 051)410-4236

the terminal operator, and the operator plans the storage sites for those containers according to the storage rules. When containers arrive at the gate the image recognition or barcode systems confirm both containers and vehicles, and if they are matched with those in 'booking prospect' forwarded in advance, the truck drivers shall receive a gate slip showing the storage site in the yard and proceed to that position(Busan Port Authority, 2004).

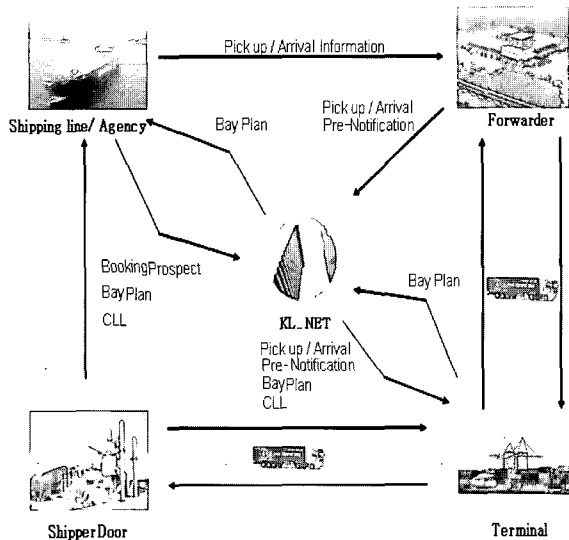

Fig. 1 The flow of information for container via EDI
source : www.klnet.co.kr

2.2 The storage operation

It is a great challenge for terminal operators to efficiently manage the containers received. There are usually two methods for storage the 'grouping' and the 'random grounding' method. The former method is to assign enough storage area to the export containers in a group for a prospective vessel with reference to the relevant documents such as 'booking prospect' and 'container loading list' transmitted by shipping companies prior to the vessel calling. The principles of this method are very simplified, but as the export containers are assigned to only one 'zone' for storage this may not be efficient for a terminal with insufficient storage area.

On the contrary the random grounding method is to assign storage area to the export containers for a prospective vessel in multiple stacking blocks considering the condition of stacking blocks. That is unlike the 'grouping method' the containers to be loaded on board a particular vessel can be stored at several storage blocks. The merit of this is to use existing storage space efficiently on condition that a complex storage management system works(Yoo, 2004).

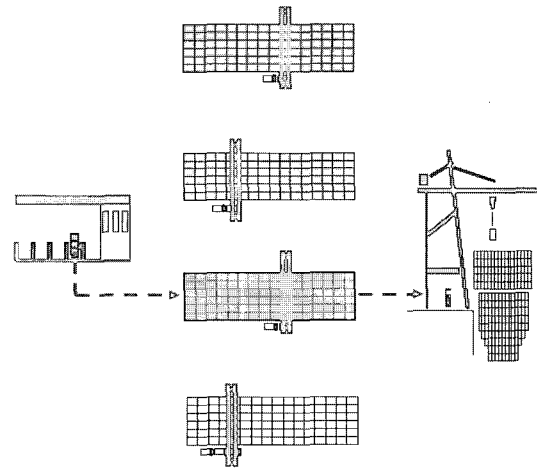

Fig. 2 Grouping method

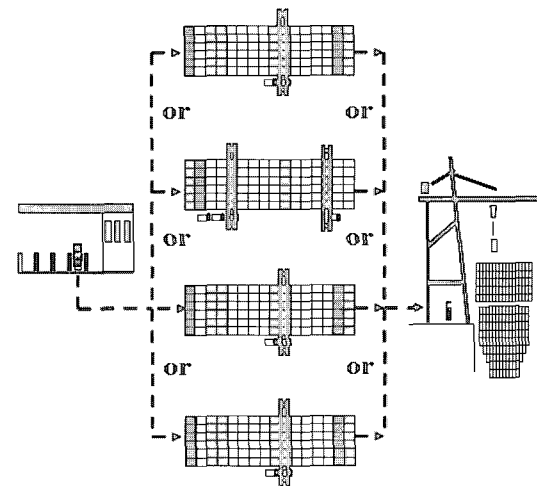

Fig. 3 Random grounding method

2.3 Limitations on Terminal Operation

1) The gate operation

Several problems in the gate operation can be pointed out. The first is the limitation of information on containers. When a vehicle arrives at the gate, the information of the container is not transmitted in advance causing delays in gate process. Moreover, the information of vehicles and containers transmitted in advance is occasionally found to be incorrect. Another point is that the common gate systems, the barcode and the image recognition system, are considered as getting unsatisfied in terms of the processing time. The former takes approximately 30 seconds and the latter 40 to process the arriving containers. Technically, the systems also have some limitations the barcode is vulnerable to the loss and damage and the image recognition system records a low rate of recognition, around 60% in average and even 20% in bad weather condition(Busan Metropolitan City, 2004).

2) The storage yard operation

The most serious problem with storage yard operation faced by Korean container terminals is the insufficient yard space resulting in depending on off-dock container yard(ODCY). In average the capacity of storage is around 60 to 70 percent level of quay handling capacity.

Another aspect, more related to operation, is the unpredictable and wide range of delivery time frequency of exports containers. A statistics shows the arrival time of incoming containers to a terminal ranging from 6 days in advance of the designated vessel arrival to the day of departure of the vessel. The frequency is as: 10% of containers arrive within 24 hours of the vessel calling; 40% of containers arrive in 1 day advance; 20% in two days; 20% in 3 days; and 10% in 4~6 days(Ministry of Commerce, Resource and Energy, 2004).

In such a situation the storage planning is carried out depending on the staff's experience or intuition rather than on the prediction of individual container's arrival time. Consequently, the containers are stored temporarily and subject to rehandling work for ship loading resulting in low utilization of the limited resources such as container yard.

3. The Concept and Application of RFID

3.1 The concept of RFID

Radio Frequency Identification (RFID) seems to emerge as the advanced technology for improving the efficiency and productivity of container terminals. It is expected that this technology will replace barcodes adopted as a gate system in most Korean container terminals in the near future. Basically, RFID is made up of the two components: the transponder and the reader. The former is located on the object to be identified, and the latter can be located on the position desired to identify the object(Ngai, 2005).

Fig. 4 shows the concept of RFID system for container transportation. RFID tag is attached to the container and the windshield of the vehicle.

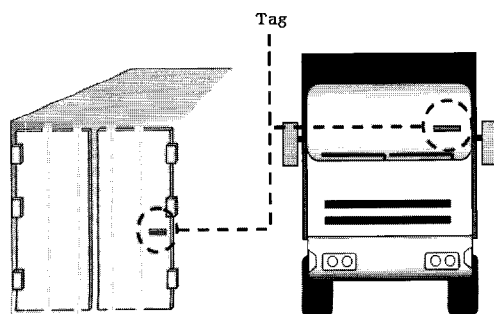

Fig. 4 The location for the installation of RFID tag

The readers are installed at the tollgate on highway and the gate of container terminals.

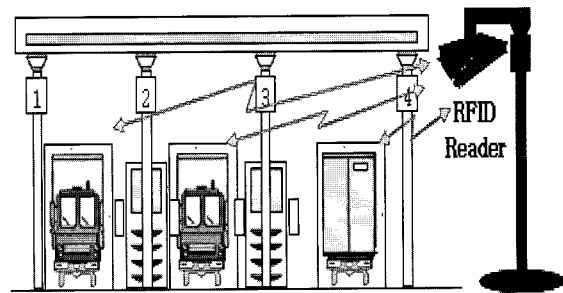

Fig. 5 The location of reader at the tollgate and the gate

A server computer is installed in the container terminal, which allows the readers to communicate with the system. When a vehicle arrives at the tollgate the reader installed there communicates with the tag on vehicles and the acquired information is transmitted to the server computer. The container terminal uses this information to forecast the arrival time of the export containers. This information enables the staff to manage containers on the basis of time in advance which may result in enhancing the efficiency and the productivity of terminal operation.

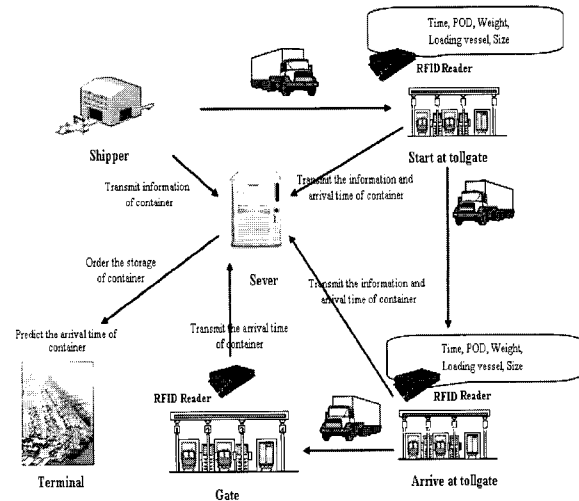

Fig. 6 The concept on RFID system

3.2 The Application of RFID

1) The gate operation

As stated previously the common gate systems, the barcode and the image recognition have some limitations such as shortcomings on data transmission in advance, relatively long processing time and low rate of recognition.

The introduction of RFID seems to cope with such disadvantages entirely or partially. When shippers or forwarders send containers to container terminal, the

information on containers such as discharging port, loading vessel, weight category, size etc., is inputted into RFID tag in detail. The reader at the gate communicates with the tag on the container and the vehicle, and the reader transmits the information to the server computer. Then the server computer compares the information with the holding information. If they match, the container would come in the terminal and the gate operation would send container to the assigned storage site.

In such a situation, a series of the events generate at one time and it takes less than a few seconds to process a container at the gate, significantly reducing the burden on the gate.

2) The storage management

Well-organized storage management is essential for terminal staff to achieve a high productivity at the terminal (Chnt, 1999). In practice, operators make a storage plan depending on the information on 'container loading list' provided by shipping companies without knowing when containers are delivered into the terminal as with the existing system it is impossible to keep tracking the location of the container movements.

With the RFID-based system, however, the terminal staff concerned knows how far away the incoming export containers from the terminal, and then it is possible for him to predict the arrival time and the expected volume of traffic at the terminal at certain time enabling the storage plan based on the time in advance. Table 1 illustrates improvements in a comparison with the previous works

Table 1 Improvements in a comparison with the previous works

Limitation of the previous works	Yoo (2004)	• The traffic prediction through the past data before the storage plan
	Lee (2003)	• When containers arrive at the gate, system plans and storages at the same time
Improvements through this study	• Raise visibility about the container's location • Forecast the arrival time of the export containers. • The decrease on human error	

As an example, the Fig. 7 and Fig. 8 show that RFID system is very useful for the storage planning. The condition is that there are two loading vessels, 'A' and 'B', having different discharging port. The vessel 'A' arrives at a quay in two days time and runs between Busan and Hong Kong, while the vessel 'B' arrives in three days time and run between Busan and Hong Kong via Kaohsiung.

Fig. 7 shows the current storage method annexing the

random grounding and the grouping. This method depends on the information available from the documents such as 'container loading list' or 'booking prospect' provided via EDI. Without knowing the delivery time of the export containers the storage position of containers is determined on their arrival. When the vessel is berthing the export containers are transferred to the quay side to be loaded on board according to the sequence made to secure safety of the vessel and the orderly unloading containers at discharging port. Accordingly the containers stacked in the yard have to be shifted or rehandled to match the loading sequence.

Fig. 8 shows the storage method under the adoption of RFID system. The condition is the same as that of Fig. 7. The container terminal can plan the storage on the basis of the expected delivery time of containers in advance. The plan can determine the place to put the individual container corresponding with the prescheduled sequence, and, so that, fewer container shifting or rehandling movements are needed to load them on board the vessel.

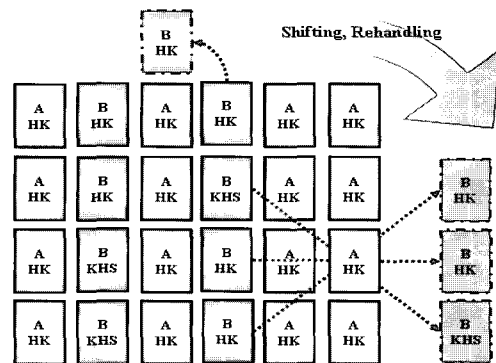

Fig. 7 The storage strategy before using RFID

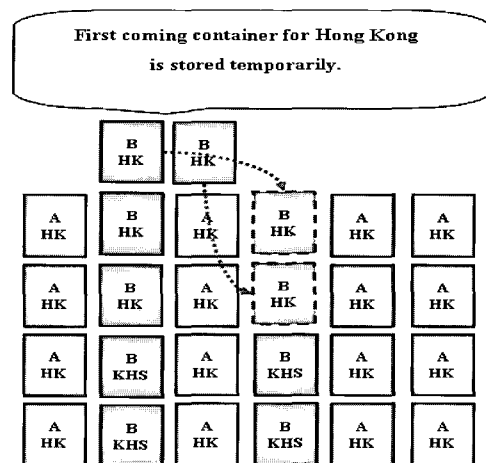

Fig. 8 The storage strategy after using RFID

4. Conclusion

This paper has attempted to examine briefly the

feasibility of adopting RFID system to improve the operational efficiency and productivity with respect to both the gate and the container yard. It is suggested that the RFID system can make the gate operation efficient reducing the processing time taken and improving the reliability of information.

In addition, terminal operators using RFID system will be able to plan the storage of containers in the yard more efficiently than using the existing systems because they can secure the real time information and the expected delivery time of the containers. This can reduce the shifting and rehandling work resulting in increasing the productivity. Considering the insufficient storage space in Korean container terminals the storage yard is the key area where planning and controlling activities can exert a great influence on terminal productivity.

We believe that RFID is an emerging advanced technology for the container terminals. Actually, several countries are undertaking in depth research on adopting RFID in the field of container transportation. Such environment puts more emphasis on the need to carry out a detailed survey of RFID systems in terms of technical feasibility and the application in various sector of terminals such as allocation of handling equipments in the yard etc.,. The cost aspect is also a critical factor which needs to be scrutinized in detail. However, there is a limit to this paper.

In future, we'll try to improve and advance the quality of this research considering the aspect of not only cost but also import containers.

Reference

- [1] Busan Metropolitan City (2004), "A study on the promotion plan of port logistics industry in Busan.", pp.373-409.
- [2] Busan Port Authority (2004), "A Building Project of U-port by RFID".
- [3] Chnt, T. (1999), "Yard Operations in the container terminal—a study in the 'unproductive moves' ", *MARIT. POL. MGMT.*, 26(1), pp.27-38.
- [4] Lee, C. M. (2003), "Export yard planning integrated with yard monitoring system in container terminal", Korea Maritime University.
- [5] Ministry of Commerce, Resource and Energy (2004), "A study on the development of automatic assignment planning systems for container terminal".
- [6] Ministry of Construction and Transportation (1997), "Modelling yard and ship planning for efficient operation of container terminal", a research report.
- [7] Ngai, E.W.T., Cheng, T.C.E., Au, S., and Lai, K. H. (2005), "Mobile commerce integrated with RFID technology in a container depot", *Decision Support Systems*.
- [8] Yoo, J. Y., Song, Y. S., Nam, K. C., and Kwak, K. S. (2004), "An Efficient Method for Terminal", Paper presented at Korea Institute of Navigation and Port Research, April 23-24.

Received 7 December 2005

Accepted 28 December 2005