

# Parametric Approaches for Eigenstructure Assignment in High-order Linear Systems

Guang-Ren Duan

**Abstract:** This paper considers eigenstructure assignment in high-order linear systems via proportional plus derivative feedback. It is shown that the problem is closely related with a type of so-called high-order Sylvester matrix equations. Through establishing two general parametric solutions to this type of matrix equations, two complete parametric methods for the proposed eigenstructure assignment problem are presented. Both methods give simple complete parametric expressions for the feedback gains and the closed-loop eigenvector matrices. The first one mainly depends on a series of singular value decompositions, and is thus numerically very simple and reliable; the second one utilizes the right factorization of the system, and allows the closed-loop eigenvalues to be set undetermined and sought via certain optimization procedures. An example shows the effect of the proposed approaches.

**Keywords:** High-order linear systems, eigenstructure assignment, proportional plus derivative feedback, parametric solutions, singular value decomposition, right factorization.

## 1. INTRODUCTION

This paper is concerned with the control of the following high-order dynamical linear system

$$A_m x^{(m)} + A_{m-1} x^{(m-1)} + \dots + A_1 \dot{x} + A_0 x = Bu, \quad (1)$$

where  $x \in \mathbb{R}^n$ , and  $u \in \mathbb{R}^r$ , are the state vector and the control vector, respectively;  $A_i \in \mathbb{R}^{n \times n}$ ,  $i = 0, 1, 2, \dots, m$ , and  $B \in \mathbb{R}^{n \times r}$ , are the system coefficient matrices, which satisfy the following assumption.

**Assumption A1:**  $\det(A_m) \neq 0$ ,  $\text{rank}(B) = r$ .

The above system (1) reduces to a second-order linear system and a first-order linear system when  $m$  takes the value of 2 and 1, respectively.

Eigenstructure assignment in first-order linear systems has been studied by many authors (see [1-4] and the references therein). As a special case of (1), second-order linear systems have found applications in many fields, such as vibration and structural analysis, spacecraft control and robotics control, and hence have attracted much attention ([5-18]).

Concerning the control of second-order linear systems, many results are focused on stabilization (for e.g. [6,7]) and pole assignment ([8-11]). Regarding eigenstructure assignment in second-order linear systems, there have also been some results ([12-18]).

Reference [12] considers eigenstructure assignment in a special class of second-order linear systems using inverse eigenvalue methods. Reference [13] proposes an algorithm for eigenstructure assignment in second-order linear systems, with the system coefficient matrices satisfying certain symmetric positivity condition. This algorithm is attractive because it utilizes only the original system data. In [14], an effective method for partial eigenstructure assignment is proposed for second-order linear systems with all the coefficient matrices symmetric. In [15], the problem of robust eigenstructure assignment is treated for second-order linear systems. The design degree of freedom provided by eigenstructure assignment is utilized to minimize the condition number of the closed-loop system. Another approach for eigenstructure assignment in second-order linear systems using a proportional plus derivative feedback controller is proposed by [16], where simple, general, and complete parametric expressions in direct closed forms for both the closed-loop eigenvector matrix and the feedback gains are established. As in [13], the approach utilizes directly the original system data, and involves manipulations on only  $n$ -dimensional matrices. However, the approach has the disadvantage that it requires the controllability of the matrix pair  $(A, B)$ , which is not satisfied in some applications. Very recently, [17,18] consider eigenstructure

Manuscript received October 2, 2004; revised March 5, 2005; accepted April 7, 2005. Recommended by Editorial Board member Jae-Weon Choi under the direction of Editor-in-Chief Myung Jin Chung. This work was supported by the National Outstanding Youth Foundation of China (No. 69925308).

Guang-Ren Duan is with the Center for Control and Guidance Technology, Harbin Institute of Technology, P. O. Box 416, Harbin, 150001, P. R. China (e-mails: grduan@ieee.org, grduan@iee.org).

assignment in second-order linear systems via proportional plus derivative feedback. It relates the problem with a type of so-called second-order Sylvester matrix equations. Through establishing two general parametric solutions to the type of matrix equations, two complete parametric methods for the proposed eigenstructure assignment problem are presented. Both methods give simple complete parametric expressions for the feedback gains and the closed-loop eigenvector matrices.

Letting

$$z^T = \begin{bmatrix} x^T & \dot{x}^T & \cdots & (x^{(m-1)})^T \end{bmatrix},$$

the high-order linear system (1) can be converted into the following extended first-order state-space model

$$\dot{z} = A_e z + B_e u, \quad (2)$$

where

$$A_e = \begin{bmatrix} 0 & I_n & & \\ & & \ddots & \\ & & & I_n \\ -A_m^{-1}A_0 & -A_m^{-1}A_1 & \cdots & -A_m^{-1}A_{m-1} \end{bmatrix}, \quad (3)$$

$$B_e = \begin{bmatrix} 0 & \cdots & 0 & (A_m^{-1}B)^T \end{bmatrix}^T. \quad (4)$$

Therefore, control of the high-order linear system (1) can be realized by investigating the corresponding extended first-order state-space model (2)-(4). As a consequence, the results will eventually involve manipulations on  $mn$  dimensional matrices  $A_e$  and  $B_e$ . Furthermore, such a conversion process may be ill-conditioned and produces a first-order model with very low precision.

In this paper we consider eigenstructure assignment in the high-order linear system (1) via proportional plus derivative coordinate control. The intension is to provide simple direct methods which utilize only the original system coefficients  $A_i$ ,  $i=1,2,\dots,m$ . Two complete parametric approaches are presented. Both approaches provide very simple, complete parametric expressions for the closed-loop eigenvector matrices and the feedback gains. These expressions contain a group of parameter vectors which represent the design degrees of freedom and can be properly further chosen to produce a closed-loop system with some desired system specifications. The first approach mainly depends on a series of singular value decompositions, and is thus numerically very simple and reliable; the second one, which utilizes the right factorization of the system, happens to be a natural generalization of the parametric method proposed in [1] (see also [2,3]) for eigenstructure assignment in first-order state-space descriptor linear systems. Furthermore, the presented

results also generalize the parametric methods proposed in [17] (see also [18]) for eigenstructure assignment in second-order linear systems. With this approach, besides the group of parameter vectors, the closed-loop eigenvalues may also be treated as a part of the degrees of design freedom since they appear directly in the expressions of the eigenvector matrix and the feedback gains, and hence are not necessarily chosen *a priori*, and can be set undetermined and sought via certain optimization procedures.

The paper is composed of six sections. Section 2 gives the formulation of the eigenstructure assignment problem for high-order linear systems, and also relates it to a problem of solving a type of high-order Sylvester matrix equations. Section 3 proposes two complete parametric solutions to the type of  $m$ -th order Sylvester matrix equations. Based on these solutions proposed in Section 3, two parametric methods are proposed in Section 4 for the formulated eigenstructure assignment problem. In Section 5, two algorithms are further presented. As an application, the control of a three-axis dynamic flight motion simulator is considered in Section 6.

## 2. PROBLEM FORMULATION

For the high-order dynamical system (1), by choosing the following control law

$$u = F_0 x + F_1 \dot{x} + \cdots + F_{m-1} x^{(m-1)}, \quad F_i \in \mathbb{R}^{r \times n}, \quad (5)$$

we obtain the closed-loop system as follows:

$$\begin{aligned} & A_m x^{(m)} + (A_{m-1} - BF_{m-1})x^{(m-1)} + \cdots \\ & + (A_1 - BF_1)\dot{x} + (A_0 - BF_0)x = 0. \end{aligned} \quad (6)$$

Note that  $\det(A_m) \neq 0$ , the above system (6) can be written in the first-order state-space form

$$\dot{z} = A_{ec} z \quad (7)$$

with

$$A_{ec} = \begin{bmatrix} 0 & I_n & & \\ & & \ddots & \\ & & & I_n \\ A_0^c & A_1^c & \cdots & A_{m-1}^c \end{bmatrix}, \quad (8)$$

where

$$A_i^c = -A_m^{-1}(A_i - BF_i), \quad i=0,1,2,\dots,m-1.$$

Recall the fact that a nondefective matrix possesses eigenvalues which are less sensitive to the parameter perturbations in the matrix, we here require the closed-loop matrix  $A_{ec}$  to be nondefective, that is, the Jordan form of the matrix  $A_{ec}$  possesses a diagonal form:

$$\Lambda = \text{diag}(s_1, s_2, \dots, s_{mn}), \quad (9)$$

where  $s_i, i=1,2,\dots, mn$ , are clearly the eigenvalues of the matrix  $A_{ec}$ .

**Lemma 1:** Let  $A_{ec}$  and  $\Lambda$  be given by (8) and (9), respectively. Then there exist matrices  $V_i \in \mathbb{C}^{n \times mn}$ ,  $i=0,1,2,\dots,m-1$ , satisfying

$$A_{ec} \begin{bmatrix} V_0 \\ V_1 \\ \vdots \\ V_{m-1} \end{bmatrix} = \begin{bmatrix} V_0 \\ V_1 \\ \vdots \\ V_{m-1} \end{bmatrix} \Lambda \quad (10)$$

if and only if there exists a matrix  $V \in \mathbb{C}^{n \times mn}$  satisfying

$$A_m V \Lambda^m + (A_{m-1} - BF_{m-1}) V \Lambda^{m-1} + \dots + (A_1 - BF_1) V \Lambda + (A_0 - BF_0) V = 0. \quad (11)$$

In this case, the set of matrices  $V_i, i=0,1,2,\dots,m-1$ , satisfying (10) are given by

$$V_0 = V, \text{ and } V_i = V_{i-1} \Lambda, \quad i=1,2,\dots,m. \quad (12)$$

**Proof:** Since

$$\begin{bmatrix} V_0 \\ V_1 \\ \vdots \\ V_{m-1} \end{bmatrix} \Lambda = \begin{bmatrix} V_0 \Lambda \\ V_1 \Lambda \\ \vdots \\ V_{m-1} \Lambda \end{bmatrix},$$

and

$$A_{ec} \begin{bmatrix} V_0 \\ V_1 \\ \vdots \\ V_{m-1} \end{bmatrix} = \begin{bmatrix} 0 & I_n & & \\ & & \ddots & \\ & & & I_n \end{bmatrix} \begin{bmatrix} V_0 \\ V_1 \\ \vdots \\ V_{m-1} \end{bmatrix} = \begin{bmatrix} V_1 \\ \vdots \\ V_{m-1} \\ \sum_{i=0}^{m-1} A_i^c V_i \end{bmatrix},$$

the equation (10) is clearly equivalent to

$$V_i = V_{i-1} \Lambda, \quad i=1,2,\dots,m \quad (13)$$

and

$$-\sum_{i=0}^{m-1} A_m^{-1} (A_i - BF_i) V_i = V_{m-1} \Lambda. \quad (14)$$

Clearly, the equation (14) can be equivalently converted into

$$\sum_{i=0}^{m-1} (A_i - BF_i) V_i + A_m V_{m-1} \Lambda = 0. \quad (15)$$

Using the relations in (13), we can obtain the relations

$$V_i = V \Lambda^i, \quad i=1,2,\dots,m-1.$$

Substituting these relations into (15) yields

$$A_m V_0 \Lambda^m + (A_{m-1} - BF_{m-1}) V_0 \Lambda^{m-1} + \dots + (A_1 - BF_1) V_0 \Lambda + (A_0 - BF_0) V_0 = 0.$$

With the above deduction, the conclusion obviously follows.  $\square$

The above lemma states that the Jordan matrix of  $A_{ec}$  is  $\Lambda$  if and only if there exists a matrix  $V \in \mathbb{C}^{n \times mn}$  satisfying (15), and in this case the corresponding eigenvector matrix of  $A_{ec}$  is given by

$$V_{ec} = \begin{bmatrix} V \\ V \Lambda \\ \vdots \\ V \Lambda^{m-1} \end{bmatrix}. \quad (16)$$

With the above understanding, the problem of eigenstructure assignment in the high-order dynamical system (1) via the proportional plus derivative feedback law (5) can be stated as follows.

**Problem ESA** (Eigenstructure assignment): Given system (1) satisfying Assumption A1, and the matrix  $\Lambda = \text{diag}(s_1, s_2, \dots, s_{mn})$ , with  $s_i, i=1,2,\dots, mn$ , being a group of self-conjugate complex numbers (not necessarily distinct), find a general parametric form for the matrices  $F_i \in \mathbb{R}^{r \times n}$ ,  $i=0,1,2,\dots,m-1$ , and  $V \in \mathbb{C}^{n \times mn}$  such that the matrix equation (11) and the condition

$$\det \begin{bmatrix} V \\ V \Lambda \\ \vdots \\ V \Lambda^{m-1} \end{bmatrix} \neq 0, \quad (17)$$

are satisfied.

Letting

$$W = F_{m-1} V \Lambda^{m-1} + \dots + F_1 V \Lambda + F_0 V$$

$$= [F_0 \quad F_1 \quad \dots \quad F_{m-1}] \begin{bmatrix} V \\ V \Lambda \\ \vdots \\ V \Lambda^{m-1} \end{bmatrix}, \quad (18)$$

then (11) becomes

$$A_m V \Lambda^m + \dots + A_1 V \Lambda + A_0 V = BW. \quad (19)$$

Clearly, (19) becomes the type of generalized Sylvester matrix equation investigated in [1,2,19] when  $m=1$ , and becomes the second-order (or quadratic) Sylvester matrix equation [17,18] when

$m \neq 2$ . Due to this fact, we call the equation (19) the  $m$ -th order generalized Sylvester matrix equation.

It follows from the above deduction that, once a pair of matrices  $V$  and  $W$  satisfying the high-order generalized Sylvester matrix equation (19) and condition (17) are obtained, the control gain matrices  $F_i, i = 0, 1, 2, \dots, m-1$ , can be easily obtained as

$$[F_0 \ F_1 \ \dots \ F_{m-1}] = W \begin{bmatrix} V \\ V\Lambda \\ \vdots \\ V\Lambda^{m-1} \end{bmatrix}^{-1}.$$

Therefore, to solve Problem ESA, the key step is to solve the following problem.

**Problem HSE** (High-order Sylvester equation):

Given the matrices  $A_i \in \mathbb{R}^{n \times n}, i = 0, 1, 2, \dots, m, B \in \mathbb{R}^{n \times r}$  satisfying Assumption A1, and a diagonal matrix

$$\Lambda = \text{diag}(s_1, s_2, \dots, s_q) \in \mathbb{C}^{q \times q}, \tag{20}$$

find a parameterization for all the matrices  $V \in \mathbb{C}^{n \times q}$  and  $W \in \mathbb{C}^{r \times q}$  satisfying the  $m$ -th order Sylvester matrix equation (19).

It should be noted that the number of columns of the matrices  $V, W$  and  $\Lambda$  in the above Problem HSE are changed to  $q$  because this makes the Problem HSE more general.

### 3. SOLUTION TO PROBLEM HSE

Denote

$$V = [v_1 \ v_2 \ \dots \ v_q], \tag{21}$$

$$W = [w_1 \ w_2 \ \dots \ w_q], \tag{22}$$

then, in view of (20), we can convert the high-order Sylvester matrix equation (19) into the following column form

$$(s_i^m A_m + s_i^{m-1} A_{m-1} + \dots + s_i A_1 + A_0)v_i = Bw_i, \tag{23}$$

$i = 1, 2, \dots, q.$

#### 3.1. Case of prescribed $s_i, i = 1, 2, \dots, q$

The equations in (23) can be further written in the following form

$$\Pi_i \begin{bmatrix} v_i \\ w_i \end{bmatrix} = 0, \quad i = 1, 2, \dots, q, \tag{24}$$

where

$$\Pi_i = \begin{bmatrix} s_i^m A_m + s_i^{m-1} A_{m-1} + \dots + s_i A_1 + A_0 & -B \end{bmatrix}, \tag{25}$$

$i = 1, 2, \dots, q.$

This states that

$$\begin{bmatrix} v_i \\ w_i \end{bmatrix} \in \ker \Pi_i, \quad i = 1, 2, \dots, q. \tag{26}$$

The following algorithm produces two sets of constant matrices  $N_i$  and  $D_i, i = 1, 2, \dots, q$ , to be used in the representation of the solution to the matrix equation (19).

**Algorithm P1** (Solving  $N_i$  and  $D_i$ ):

**Step 1:** Through applying SVD to the matrices  $\Pi_i, i = 1, 2, \dots, q$ , obtain two sets of unitary matrices  $P_i \in \mathbb{C}^{n \times n}$  and  $Q_i \in \mathbb{C}^{(n+r) \times (n+r)}, i = 1, 2, \dots, q$ , satisfying

$$P_i \Pi_i Q_i = \begin{bmatrix} \text{diag}(\sigma_1, \sigma_2, \dots, \sigma_{n_i}) & 0 \\ 0 & 0 \end{bmatrix}, \quad i = 1, 2, \dots, q, \tag{27}$$

where  $\sigma_k > 0, k = 1, 2, \dots, n_i$ , are the singular values of  $\Pi_i$ , and

$$n_i = \text{rank} \begin{bmatrix} s_i^m A_m + s_i^{m-1} A_{m-1} + \dots + s_i A_1 + A_0 & B \end{bmatrix}, \tag{28}$$

$i = 1, 2, \dots, q.$

**Step 2:** Obtain the matrices  $N_i \in \mathbb{C}^{n \times (n+r-n_i)}$  and  $D_i \in \mathbb{C}^{r \times (n+r-n_i)}, i = 1, 2, \dots, q$ , by partitioning the matrices  $Q_i$  as follows:

$$Q_i = \begin{bmatrix} * & N_i \\ * & D_i \end{bmatrix}, \quad i = 1, 2, \dots, q. \tag{29}$$

As a result of (27) and (29), the matrices  $N_i \in \mathbb{C}^{n \times (n+r-n_i)}$  and  $D_i \in \mathbb{C}^{r \times (n+r-n_i)}, i = 1, 2, \dots, q$ , obtained through above Algorithm P1 satisfy

$$\Pi_i \begin{bmatrix} N_i \\ D_i \end{bmatrix} = 0, \quad \text{rank} \begin{bmatrix} N_i \\ D_i \end{bmatrix} = n+r-n_i, \tag{30}$$

$i = 1, 2, \dots, q.$

This indicates that the columns of  $\begin{bmatrix} N_i \\ D_i \end{bmatrix}$  form a set of basis for  $\ker \Pi_i$ .

The above deduction clearly yields the following result.

**Theorem 1:** Let  $n_i, i = 1, 2, \dots, q$ , be defined by (28), and  $N_i \in \mathbb{C}^{n \times (n+r-n_i)}$  and  $D_i \in \mathbb{C}^{r \times (n+r-n_i)}, i = 1, 2, \dots, q$ , be obtained via Algorithm P1. Then all the matrices  $V$  and  $W$  satisfying the high-order Sylvester matrix equation (19) can be parameterized by columns as follows:

$$\begin{bmatrix} v_i \\ w_i \end{bmatrix} = \begin{bmatrix} N_i \\ D_i \end{bmatrix} f_i, \quad i = 1, 2, \dots, q, \tag{31}$$

where  $f_i \in \mathbb{C}^{n+r-n_i}$ ,  $i=1,2,\dots,q$ , are a set of arbitrary parameter vectors.

**Definition 1:** The high-order dynamical system (1) is called controllable if and only if the corresponding extended first-order state-space representation (2)-(4) is controllable.

Regarding the controllability of system (1), we have the following basic result which is an extension of the well-known PBH criterion.

**Lemma 2:** The high-order dynamical system (1) is controllable if and only if

$$\text{rank} \begin{bmatrix} s^m A_m + \dots + sA_1 + A_0 & B \end{bmatrix} = n, \quad \forall s \in \mathbb{C}. \quad (32)$$

**Proof:** By the well-known PBH criterion, we need only to show that condition (32) is equivalent to

$$\text{rank} \begin{bmatrix} A_e - sI_{mn} & B_e \end{bmatrix} = mn, \quad \forall s \in \mathbb{C},$$

where  $A_e$  and  $B_e$  are given by (3).

Since

$$\begin{aligned} & \text{rank} \begin{bmatrix} A_e - sI_{mn} & B_e \end{bmatrix} \\ &= \text{rank} \begin{bmatrix} -sI_n & I_n & & & 0 \\ & \ddots & & & \vdots \\ & & -sI_n & I_n & 0 \\ -A_m^{-1}A_0 & -A_m^{-1}A_1 & \dots & -A_m^{-1}A_{m-1} - sI_n & A_m^{-1}B \end{bmatrix} \\ &= \text{rank} \begin{bmatrix} -sI_n & I_n & & & 0 \\ & \ddots & & & \vdots \\ & & -sI_n & I_n & 0 \\ -A_0 & -A_1 & \dots & -A_{m-1} - sA_m & B \end{bmatrix} \\ &= \text{rank} \begin{bmatrix} 0 & I_n & & & 0 \\ 0 & -sI_n & I_n & & 0 \\ \vdots & & \ddots & & \vdots \\ 0 & & & -sI_n & I_n & 0 \\ -\sum_{i=0}^m A_i s^i & -A_1 & -A_2 & \dots & -A_{m-1} - sA_m & B \end{bmatrix} \\ &= n(m-1) + \text{rank} \begin{bmatrix} \sum_{i=0}^m A_i s^i & B \end{bmatrix}, \end{aligned}$$

the conclusion clearly follows.  $\square$

Based on the above lemma, the following corollary of Theorem 1 can be immediately derived.

**Corollary 1:** Let system (1) be controllable, and  $\Lambda$  be given by (20), then the degrees of freedom existing in the general solution to the high-order Sylvester matrix equation (19) is  $qr$ .

**Proof:** Due to the controllability of system (1), we have from Lemma 2 that  $n_i = n$ ,  $i=1,2,\dots,q$ . Thus the conclusion immediately follows from Theorem 1.

### 3.2. Case of undetermined $s_i$ , $i=1,2,\dots,q$

By performing the right factorization of

$$G(s) = \left( s^m A_m + s^{m-1} A_{m-1} + \dots + sA_1 + A_0 \right)^{-1} B,$$

we can obtain a pair of polynomial matrices  $N(s) \in \mathbb{R}^{n \times r}[s]$  and  $D(s) \in \mathbb{R}^{r \times r}[s]$  satisfying

$$(s^m A_m + \dots + sA_1 + A_0)^{-1} B = N(s)D^{-1}(s). \quad (33)$$

**Theorem 2:** Let the system (1) be controllable, and  $N(s) \in \mathbb{R}^{n \times r}[s]$  and  $D(s) \in \mathbb{R}^{r \times r}[s]$  satisfy the right factorization (33). Then

(1) The matrices  $V$  and  $W$  given by (21), (22) with

$$\begin{bmatrix} v_i \\ w_i \end{bmatrix} = \begin{bmatrix} N(s_i) \\ D(s_i) \end{bmatrix} f_i, \quad i=1,2,\dots,q \quad (34)$$

satisfy the high-order Sylvester matrix equation (19) for all  $f_i \in \mathbb{C}^r$ ,  $i=1,2,\dots,q$ .

(2) When

$$\text{rank} \begin{bmatrix} N(s_i) \\ D(s_i) \end{bmatrix} = r, \quad i=1,2,\dots,q \quad (35)$$

hold, (34) gives all the solutions to Problem HSE.

**Proof:** It follows from (33) that

$$(s_i^m A_m + \dots + s_i A_1 + A_0)N(s_i) - BD(s_i) = 0, \quad (36) \\ i=1,2,\dots,q.$$

Using (34) and (36), yields

$$\begin{aligned} & (s_i^m A_m + \dots + s_i A_1 + A_0)v_i - Bw_i \\ &= \left[ (s_i^m A_m + \dots + s_i A_1 + A_0)N(s_i) - BD(s_i) \right] f_i \\ &= 0, \quad i=1,2,\dots,q. \end{aligned}$$

This states that the equations in (23) hold. Therefore, the first conclusion of the theorem is true.

It follows from Corollary 1 that, under the controllability of system (1), the degrees of freedom existing in the general solution to the matrix equation (19), with  $\Lambda$  given by (20), is  $qr$ , while in the solution (34), the number of free parameters just equal to  $qr$ . Further, it is clear that all these parameters in the solution (34) have contributions when condition (35) holds. With this we complete the proof.  $\square$

**Remark 1:** The right factorization (33) performs a fundamental role in the solution (34). When  $s_i$ ,  $i=1,2,\dots,q$ , are chosen to be different from the zeros of  $\det(s^m A_m + s^{m-1} A_{m-1} + \dots + sA_1 + A_0)$ , we can take

$$\begin{cases} N(s) = \text{Adj} \left( s^m A_m + s^{m-1} A_{m-1} + \dots + sA_1 + A_0 \right) B \\ D(s) = \det \left( s^m A_m + s^{m-1} A_{m-1} + \dots + sA_1 + A_0 \right) I_r. \end{cases} \quad (37)$$

In many practical applications, we often have  $r = n$ , and  $\det B \neq 0$ . In this case, note that

$$\begin{aligned} & \left( s^m A_m + s^{m-1} A_{m-1} + \dots + sA_1 + A_0 \right)^{-1} B \\ &= \left[ B^{-1} \left( s^m A_m + s^{m-1} A_{m-1} + \dots + sA_1 + A_0 \right) \right]^{-1}, \end{aligned}$$

we can take

$$\begin{cases} N(s) = I_n \\ D(s) = B^{-1} \left( s^m A_m + s^{m-1} A_{m-1} + \dots + sA_1 + A_0 \right). \end{cases} \quad (38)$$

For the general case, one can refer to [21,22] for some general numerical algorithms solving such right factorizations. Alternatively, the following simple procedure can also be used.

**Algorithm P2** (Right coprime factorization):

**Step 1:** Under the controllability of system (1), find a pair of unimodular matrices  $P(s)$  and  $Q(s)$ , of appropriate dimensions, satisfying

$$P(s) \begin{bmatrix} s^m A_m + \dots + sA_1 + A_0 & -B \end{bmatrix} Q(s) = \begin{bmatrix} I_n & 0 \end{bmatrix}.$$

**Step 2:** Obtain the pair of polynomial matrices  $N(s) \in \mathbb{R}^{n \times r}[s]$  and  $D(s) \in \mathbb{R}^{r \times r}[s]$  by partitioning the unimodular matrix  $Q(s)$  as follows:

$$Q(s) = \begin{bmatrix} * & N(s) \\ * & D(s) \end{bmatrix}.$$

It is worth pointing out that the pair of polynomial matrices  $N(s) \in \mathbb{R}^{n \times r}[s]$  and  $D(s) \in \mathbb{R}^{r \times r}[s]$  satisfying the right factorization (33) obtained from the above Algorithm P2 are right coprime since

$$\text{rank} \begin{bmatrix} N(s) \\ D(s) \end{bmatrix} = r, \quad \forall s \in \mathbb{C}.$$

This condition certainly implies the condition (35), which ensures the completeness of the solution (34).

To finish this section, let us finally give a remark on the extension of the result.

**Remark 2:** The main results in this section can be easily extended into the case that the matrix  $\Lambda$  is a general Jordan form. In fact, when  $\Lambda$  is replaced with the following Jordan matrix

$$J = \text{Blockdiag}(J_1, J_2, \dots, J_p) \in \mathbb{C}^{q \times q},$$

with

$$J_i = \begin{bmatrix} s_i & 1 & & \\ & s_i & \ddots & \\ & & \ddots & 1 \\ & & & s_i \end{bmatrix} \in \mathbb{C}^{p_i \times p_i}, \quad i=1,2,\dots,p,$$

following the development in [1,2,19], we can show that all the matrices  $V$  and  $W$  satisfying the high-order Sylvester matrix equation (19) are given by

$$\begin{cases} V = [V_1 & V_2 & \dots & V_p] \\ V_i = [v_{i1} & v_{i2} & \dots & v_{ip_i}], \end{cases}$$

and

$$\begin{cases} W = [W_1 & W_2 & \dots & W_p] \\ W_i = [w_{i1} & w_{i2} & \dots & w_{ip_i}], \end{cases}$$

with

$$\begin{aligned} \begin{bmatrix} v_{ik} \\ w_{ik} \end{bmatrix} &= \begin{bmatrix} N(s_i) \\ D(s_i) \end{bmatrix} f_k + \begin{bmatrix} N^{(1)}(s_i) \\ D^{(1)}(s_i) \end{bmatrix} f_{k-1} \\ &+ \dots + \frac{1}{(k-1)!} \begin{bmatrix} N^{(k-1)}(s_i) \\ D^{(k-1)}(s_i) \end{bmatrix} f_1, \\ &k=1,2,\dots,p_i, \quad i=1,2,\dots,p, \end{aligned}$$

where  $N(s) \in \mathbb{R}^{n \times r}[s]$  and  $D(s) \in \mathbb{R}^{r \times r}[s]$  are a pair of polynomial matrices satisfying the right factorization (33) and condition (35).

### 4. SOLUTION TO PROBLEM ESA

Regarding the solution to Problem ESA, we have the following two results based on the discussion in Section 2 and the results in Section 3.

**Theorem 3:** Let  $n_i, i=1,2,\dots,mn$ , be given by (28), and  $N_i \in \mathbb{C}^{n \times (n+r-n_i)}$  and  $D_i \in \mathbb{C}^{r \times (n+r-n_i)}$ ,  $i=1,2,\dots,mn$ , be given by Algorithm P1. Then

(1) Problem ESA has a solution if and only if there exist a group of parameters  $f_i \in \mathbb{C}^{n+r-n_i}$ ,  $i=1,2,\dots,mn$ , satisfying the following constraints:

Constraint  $C1$ :  $f_i = \bar{f}_j$  if  $s_i = \bar{s}_j$ .

Constraint  $C2_a$ :  $\det V_{ca} \neq 0$ , with

$$V_{ca} = \begin{bmatrix} N_1 f_1 & N_2 f_2 & \dots & N_{mn} f_{mn} \\ s_1 N_1 f_1 & s_2 N_2 f_2 & \dots & s_{mn} N_{mn} f_{mn} \\ \vdots & \vdots & \vdots & \vdots \\ s_1^{m-1} N_1 f_1 & s_2^{m-1} N_2 f_2 & \dots & s_{mn}^{m-1} N_{mn} f_{mn} \end{bmatrix}. \quad (39)$$

(2) When the above condition is met, all the solutions to the Problem ESA are given by

$$V = [N_1 f_1 \quad N_2 f_2 \quad \dots \quad N_{mn} f_{mn}], \quad (40)$$

and

$$\begin{aligned} & [F_0 \quad F_1 \quad \dots \quad F_{m-1}] \\ &= [D_1 f_1 \quad D_2 f_2 \quad \dots \quad D_{mn} f_{mn}] V_{ca}^{-1}, \end{aligned} \quad (41)$$

where  $f_i \in \mathbb{C}^{n+r-n_i}$ ,  $i=1,2,\dots, mn$ , are an arbitrary group of parameter vectors satisfying Constraints  $C1$  and  $C2_a$ .

**Theorem 4:** Let system (1) be controllable, and  $N(s) \in \mathbb{R}^{n \times r}[s]$  and  $D(s) \in \mathbb{R}^{r \times r}[s]$  be a pair of polynomial matrices satisfying the right factorization (33) and condition (35). Then

(1) Problem ESA has a solution if and only if there exist a group of parameters  $f_i \in \mathbb{C}^r$ ,  $i=1,2,\dots, mn$ , satisfying Constraint  $C1$  and

Constraint  $C2_b$ :  $\det V_{cb} \neq 0$ , with

$$V_{cb} = \begin{bmatrix} N(s_1)f_1 & N(s_2)f_2 & \cdots & N(s_{mn})f_{mn} \\ s_1 N(s_1)f_1 & s_2 N(s_2)f_2 & \cdots & s_{mn} N(s_{mn})f_{mn} \\ \vdots & \vdots & \vdots & \vdots \\ s_1^{m-1} N(s_1)f_1 & s_2^{m-1} N(s_2)f_2 & \cdots & s_{mn}^{m-1} N(s_{mn})f_{mn} \end{bmatrix}. \quad (42)$$

(2) When the above condition is met, all the solutions to the Problem ESA are given by

$$V = [N(s_1)f_1 \quad N(s_2)f_2 \quad \cdots \quad N(s_{mn})f_{mn}], \quad (43)$$

and

$$\begin{aligned} & [F_0 \quad F_1 \quad \cdots \quad F_{m-1}] \\ & = [D(s_1)f_1 \quad D(s_2)f_2 \quad \cdots \quad D(s_{mn})f_{mn}] V_{cb}^{-1}, \end{aligned} \quad (44)$$

where  $f_i \in \mathbb{C}^r$ ,  $i=1,2,\dots, mn$ , are an arbitrary group of parameter vectors satisfying Constraints  $C1$  and  $C2_b$ .

The proof of the above two theorems can be easily carried out based on the discussion in Section 2 and the results in Section 3. The only thing which needs to be mentioned is that Constraint  $C1$  is required because it is a necessary and sufficient condition for the matrices  $F_i$ ,  $i=0,1,\dots, m-1$ , given by (41) or (44) to be real.

Before ending this section, let us make some remarks on the main results obtained above.

**Remark 3:** The above two theorems give complete parametric solutions to the Problem ESA. The free parameter vectors  $f_i$ ,  $i=1,2,\dots, mn$ , represent the degrees of freedom in the eigenstructure assignment design, and can be sought to meet certain desired system performances. It should be noted that Constraint  $C1$  is not a restriction at all, it only gives a way of selecting these design parameter vectors.

**Remark 4:** It follows from well-known pole assignment result that Problem ESA has a solution when the system (1) is controllable and the closed-loop eigenvalues  $s_i$ ,  $i=1,2,\dots, mn$ , are restricted to be distinct. In this case, there exist parameter vectors  $f_i$ ,  $i=1,2,\dots, mn$ , satisfying Constraint  $C2_a$  or  $C2_b$ .

As a matter of fact, it can be reasoned that, in this case, "almost all" parameter vectors  $f_i$ ,  $i=1,2,\dots, mn$ , satisfy Constraint  $C2_a$  or  $C2_b$ . Therefore, in such applications Constraint  $C2_a$  or  $C2_b$  can often be neglected.

**Remark 5:** The solution given in Theorem 3 utilizes only a series of singular value decompositions, and hence is numerically very simple and reliable. As for the solution given in Theorem 4, it has the advantage that the closed-loop eigenvalues  $s_i$ ,  $i=1,2,\dots, mn$ , can be set undetermined and used as a part of extra design degrees of freedom to be sought with  $f_i$ ,  $i=1,2,\dots, mn$ , by certain optimization procedures. Furthermore, it happens that these solutions are natural generalizations of the parametric solutions in [17] (see also [18]) proposed for eigenstructure assignment in second-order linear systems, and the solution given in Theorem 4 is a natural generalization of the parametric solution in [1] (see also [2,3]) proposed for eigenstructure assignment in first-order state-space systems.

**Remark 6:** The eigenstructure assignment results can be easily extended into the defective case, that is, the case that the closed-loop system possesses a general Jordan form (refer to Remark 2). However, from the control systems design point of view, this is not desired since the eigenvalues of defective matrices are more sensitive to parameter perturbations than those of nondefective ones.

## 5. ALGORITHMS AND IMPLEMENTATION

In Section 4, we have presented two complete parametric solutions to the problem of eigenstructure assignment in the high-order linear system (1) via the controller (5). In this section, we further give two algorithms for solving this problem based on these two solutions.

### 5.1. Utilization of design parameters

An extreme advantage of the two solutions provided in Section 4 to the eigenstructure assignment problem is that they provide all the degrees of design freedom, which are represented by the set of parameter vectors  $f_i \in \mathbb{C}^r$ ,  $i=1,2,\dots, mn$ . With the second parametric approach using right factorization, the closed-loop eigenvalues  $s_i \in \mathbb{C}$ ,  $i=1,2,\dots, mn$ , may also be taken as a part of the design degrees of freedom. In practical applications, these degrees of freedom may be properly chosen to obtain a closed-loop system with some desired specifications. The key step in doing this is to relate a certain desired specification to the design degrees of freedom, and convert the specification into certain constraints on the design parameters.

Generally speaking, such constraints can be divided into three classes:

- the inequality constraints, which take the form of

$$g(s_i, f_i, i=1,2,\dots,mn) \geq 0, \quad (45)$$

with  $g$  being some scalar function of  $s_i$  and  $f_i$ ,  $i=1,2,\dots,mn$ ;

- the equality constraints, which take the form of

$$h(s_i, f_i, i=1,2,\dots,mn) = 0, \quad (46)$$

with  $h$  being some vector function of  $s_i$  and  $f_i$ ,  $i=1,2,\dots,mn$ ; and

- the minimization constraints, which take the form of

$$J(s_i, f_i, i=1,2,\dots,mn) = \min, \quad (47)$$

with  $J$  being some positive scalar index function of the design parameters  $s_i$  and  $f_i$ ,  $i=1,2,\dots,mn$ .

## 5.2. Algorithms

When a system in the form of (1) is given, and a set of desired closed-loop eigenvalues are specified, according to Theorem 3 we can realize the control of the system using the following algorithm.

**Algorithm A1** (Solution based on SVD):

**Step 1:** Solve the two series of constant matrices  $N_i$  and  $D_i$ ,  $i=1,2,\dots,mn$ , using the Algorithm P1 proposed in Section 3.

**Step 2:** Find a group of parameter vectors  $f_i$ ,  $i=1,2,\dots,mn$ , satisfying Constraints C1 and C2<sub>a</sub> together with any additional constraints in the forms of (45)-(47) (if exist).

**Step 3:** Compute, based on the parameters obtained in Step 2, the feedback gain matrices according to (39) and (41).

Based on Theorem 4, we can give the following algorithm for control of the high-order linear system (1) via the controller (5). Please note that in this algorithm the closed-loop eigenvalues can also be taken as a set of design parameters.

**Algorithm A2** (Solution based on factorization):

**Step 1:** Solve a pair of polynomial matrices  $N(s)$  and  $D(s)$  satisfying the right factorization (33) (refer to Remark 1).

**Step 2:** Find a group of parameter  $s_i$ , and  $f_i$ ,  $i=1,2,\dots,mn$ , satisfying Constraints C1 and C2<sub>b</sub>, together with any additional constraints in the forms of (45)-(47) (if exist).

**Step 3:** Compute, based on the parameters obtained in Step 2, the feedback gain matrices according to (42) and (44).

## 5.3. Matlab implementation

The above Algorithms A1 and A2 have been implemented with Matlab 6.0. A toolbox called sfpa2 has been created, which contains three main matlab functions, namely, sfpars2.m, sfpaga2.m, and sfpaqn2.m. These functions minimize, in the second step of these algorithms, the following condition number

$$J_a = \|V_{ca}\| \|V_{ca}^{-1}\| \quad \text{or} \quad J_b = \|V_{cb}\| \|V_{cb}^{-1}\|.$$

Such a requirement is well-known to ensure the robustness of the closed-loop system in the sense that the closed-loop poles are as insensitive as possible to perturbations in the system coefficient matrices. sfpars2.m performs the minimization by a random search scheme, sfpaga2.m performs the minimization using a genetic algorithm, while sfpaqn2.m performs the minimization using a quadratic Newton method. All the three programs have been verified via numerous examples to be very convenient and effective.

## 6. THE EXAMPLE

Consider a three-axis dynamic flight motion simulator system shown as in Fig. 1, which possesses a linearized model in the form of

$$A_3\ddot{x} + A_2\dot{x} + A_1\dot{x} + A_0x = Bu + f. \quad (48)$$

The state vector  $x$  and the control vector  $u$  are taken as

$$x = [\alpha \quad \beta \quad \gamma]^T, \quad u = [u_1 \quad u_2 \quad u_3]^T,$$

with  $\alpha$ ,  $\beta$  and  $\gamma$  being the angles of the three directions, and  $u_1$ ,  $u_2$  and  $u_3$  being the voltage inputs along the three axes. The coefficient matrices and the vector  $f$  are given by  $A_0 = 0_{3 \times 3}$ ,  $B = I_{3 \times 3}$ , and

$$A_3 = \begin{bmatrix} 1 & 0 & 0 \\ K_m \omega_m^2 & 0 & 0 \\ 0 & \frac{1}{K_p \omega_p^2} & 0 \\ 0 & 0 & K_e T_s T_m \end{bmatrix},$$

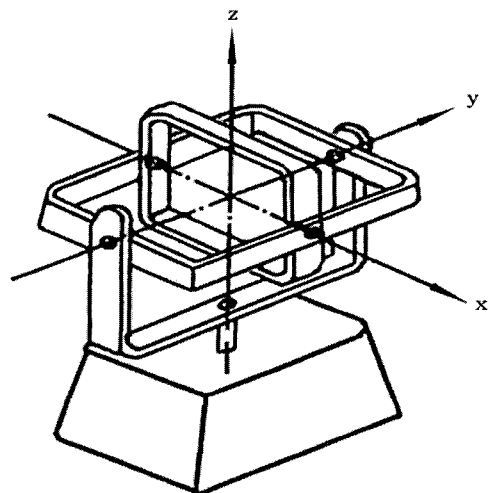

Fig. 1. The three-axis dynamic flight motion simulator.



$$A_2 = \begin{bmatrix} \frac{2\xi_m}{\omega_m K_m} & \frac{K_6}{K_m} & 0 \\ \frac{K_2}{K_p} & \frac{2\xi_p}{K_p \omega_p} & 0 \\ 0 & 0 & K_e T_m \end{bmatrix},$$

$$A_1 = \begin{bmatrix} \frac{1}{K_m} & 0 & \frac{K_6}{K_m} \\ \frac{K_1}{K_p} & \frac{1}{K_p} & \frac{K_1 + K_2}{K_p} \\ 0 & 0 & K_e \end{bmatrix}, \quad f = \begin{bmatrix} 0 \\ \frac{K_3}{K_p} \\ 0 \end{bmatrix}.$$

For the particular experimental system, the parameters in these coefficient matrices are

$$\begin{aligned} K_p &= 0.741, \quad K_m = 0.635, \quad K_e = 3.11, \\ T_s &= 1.2 \times 10^{-3}, \quad T_m = 3.19 \times 10^{-2}, \quad \omega_p = 215.37, \\ \xi_m &= 0.0332, \quad \omega_m = 205.62, \quad \xi_p = 0.0794, \\ K_1 &= 1.51 \times 10^{-5}, \quad K_2 = 4.80 \times 10^{-7}, \\ K_3 &= 2.12 \times 10^{-2}, \quad K_6 = -1.78 \times 10^{-7}, \end{aligned}$$

and they give

$$A_3 = 10^{-5} \times \begin{bmatrix} 3.724737 & 0 & 0 \\ 0 & 2.909453 & 0 \\ 0 & 0 & 11.90508 \end{bmatrix},$$

$$A_2 = 10^{-7} \times \begin{bmatrix} 5085.445 & -2.80315 & 0 \\ 6.477733 & 9950.55 & 0 \\ 0 & 0 & 992090 \end{bmatrix},$$

$$A_1 = 10^{-7} \times \begin{bmatrix} 1.5748030 & 0 & -2.80315 \\ 203.7787 & 13495280 & 210.2564 \\ 0 & 0 & 31100000 \end{bmatrix},$$

$$f = \begin{bmatrix} 0 \\ 0.0286 \\ 0 \end{bmatrix}.$$

For this system, it can be obtained that the set of open-loop poles is

$$\begin{aligned} \Gamma &= \{0, 0, 0, -6.826585 \pm 205.506625i, \\ &\quad -17.100377 \pm 214.690078i, \\ &\quad -32.625251, -800.708083\}, \end{aligned}$$

which includes three zero ones. The purpose of the design is to design a feedback in the following form

$$u = F_0 x + F_1 \dot{x} + F_2 \ddot{x},$$

such that the closed-loop system has the following desired set of poles

$$\begin{aligned} s_1 &= -110, \quad s_{2,3} = -30 \pm 25i, \\ s_i &= s_{i-2} - 20, \quad i = 4, 5, \dots, 9. \end{aligned}$$

Note that  $B = I_{3 \times 3}$ , it follows from (38) that a pair of  $N(s)$  and  $D(s)$  satisfying the right factorization (33) can be taken as

$$\begin{cases} N(s) = I_{3 \times 3} \\ D(s) = A_3 s^3 + A_2 s^2 + A_1 s. \end{cases} \quad (49)$$

Therefore, it follows from Theorem 4 that

$$\begin{aligned} V &= [f_1 \quad f_2 \quad \dots \quad f_9], \\ W &= [D(s_1)f_1 \quad D(s_2)f_2 \quad \dots \quad D(s_9)f_9], \end{aligned}$$

and

$$\begin{aligned} &[F_0 \quad F_1 \quad F_2] \\ &= [D(s_1)f_1 \quad D(s_2)f_2 \quad \dots \quad D(s_9)f_9] V_{cb}^{-1}, \end{aligned} \quad (50)$$

with

$$V_{cb} = \begin{bmatrix} f_1 & f_2 & \dots & f_9 \\ s_1 f_1 & s_2 f_2 & \dots & s_9 f_9 \\ s_1^2 f_1 & s_2^2 f_2 & \dots & s_9^2 f_9 \end{bmatrix}.$$

The design parameter vectors  $f_i \in \mathbb{C}^3$ ,  $i = 1, 2, \dots, 9$ , are required to satisfy Constraints C1 and C2<sub>b</sub>. Simply choosing

$$\begin{aligned} f_1 &= \begin{bmatrix} 1 \\ 0 \\ 0 \end{bmatrix}, \quad f_2 = \bar{f}_3 = \begin{bmatrix} 1+i \\ 0 \\ 0 \end{bmatrix}, \quad f_4 = \bar{f}_5 = \begin{bmatrix} 0 \\ 1+i \\ 0 \end{bmatrix}, \\ f_6 = \bar{f}_7 &= \begin{bmatrix} 0 \\ 0 \\ 1+i \end{bmatrix}, \quad f_8 = \bar{f}_9 = \begin{bmatrix} 1 \\ 1 \\ 1 \end{bmatrix}, \end{aligned}$$

we obtain

$$\begin{aligned} F_0 &= 10^2 \times \begin{bmatrix} -6.248246 & 23.13411 & -87.97596 \\ 0 & -0.681903 & -32.95319 \\ 0 & 13.48622 & -113.4629 \end{bmatrix}, \\ F_1 &= 10^{-5} \times \begin{bmatrix} 127216.8 & 74029.15 & -222925.5 \\ 2.037787 & 123678.7 & -83499.2 \\ 0 & 43155.91 & -42283.25 \end{bmatrix}, \\ F_2 &= 10^{-7} \times \begin{bmatrix} -58235.08 & 74026.34 & -159232.5 \\ 6.477733 & -21326.07 & -59643.79 \\ 0 & 43155.91 & 620056.3 \end{bmatrix}. \end{aligned}$$

The corresponding closed-loop eigenvalues are

$-109.999930$ ,  $-30.000029 \pm 24.999982i$ ,  
 $-49.999496 \pm 25.000211i$ ,  $-70.000287 \pm 24.999781i$ ,  
 $-90.000196 \pm 25.000554i$ , and

$$J_b = \|V_{cb}\| \|V_{cb}^{-1}\| = 444890, \|[F_0 \ F_1 \ F_2]\| = 149.34.$$

For the same problem, using our Matlab function `sfpaga2.m`, which minimizes the  $J_b$  index, we obtain the set of design parameter vectors as

$$f_1 = \begin{bmatrix} 11.55292 \\ -76.70877 \\ -24.54636 \end{bmatrix},$$

$$f_2 = \bar{f}_3 = \begin{bmatrix} 62.89707 + 76.0494i \\ -42.21224 + 41.39475i \\ 52.69122 - 60.22392i \end{bmatrix},$$

$$f_4 = \bar{f}_5 = \begin{bmatrix} 19.47224 - 12.88081i \\ -97.7156 + 97.6349i \\ -66.1718 + 65.96142i \end{bmatrix},$$

$$f_6 = \bar{f}_7 = \begin{bmatrix} -66.57559 - 74.20366i \\ -39.07198 + 37.21365i \\ 52.97427 - 81.33047i \end{bmatrix},$$

$$f_8 = \bar{f}_9 = \begin{bmatrix} 72.90513 + 59.60403i \\ 5.11942 + 35.4133i \\ 59.11232 - 53.7313i \end{bmatrix}$$

and the corresponding feedback gain matrices as

$$F_0 = \begin{bmatrix} -9.124586 & 3.555382 & -5.096869 \\ -1.972745 & -9.191742 & -2.475766 \\ 14.98329 & -3.684043 & -27.20568 \end{bmatrix},$$

$$F_1 = 10^{-2} \times \begin{bmatrix} 111.1872 & 7.294695 & -11.76649 \\ -3.724621 & 95.66864 & -6.156975 \\ 32.25638 & -4.378725 & 171.8674 \end{bmatrix},$$

$$F_2 = 10^{-4} \times \begin{bmatrix} -67.56116 & 4.78143 & -8.561459 \\ -1.831703 & -49.69357 & -5.079366 \\ 24.11178 & -2.674033 & 765.9404 \end{bmatrix}.$$

The corresponding closed-loop eigenvalues are

$-109.99999$ ,  $-30.000009 \pm 25.000052i$ ,  
 $-50.000006 \pm 25.000021i$ ,  $-69.999885 \pm 24.999975i$ ,  
 $-90.000077 \pm 24.999879i$ , and

$$J_b = \|V_{cb}\| \|V_{cb}^{-1}\| = 21776, \|[F_0 \ F_1 \ F_2]\| = 31.419.$$

## 7. CONCLUSIONS

This paper treats the problem of eigenstructure assignment in the high-order linear system (1) via

proportional plus derivative coordinate control and has achieved the following:

- Two parametric approaches are proposed, which provide very simple, complete parametric expressions for the closed-loop eigenvector matrices and the feedback gains. These expressions contain a group of parameter vectors which represent the design degrees of freedom and can be properly further chosen to produce a closed-loop system with some desired system specifications.
- The first approach mainly depends on a series of singular value decompositions, and is thus numerically very simple and reliable; the second one utilizes the right factorization of the system and also allows the closed-loop eigenvalues to be treated as a part of the degrees of design freedom since they appear directly in the expressions of the eigenvector matrix and the feedback gains.
- The second approach happens to be a natural generalization of the parametric method proposed in [3] for eigenstructure assignment in first-order state-space descriptor linear systems and that proposed in [18] for eigenstructure assignment in second-order state-space descriptor linear systems.
- The presented results are generalizations of the parametric methods proposed in [1-3,17,18] for eigenstructure assignment in first- and second-order linear systems.
- Based on the presented approaches, a matlab toolbox, `sfpa2`, for eigenstructure assignment in high-order linear systems has been created, which has been approved to be very efficient and effective.

## REFERENCES

- [1] G. R. Duan, "Solutions to matrix equation  $AV+BW=VF$  and their application to eigenstructure assignment in linear systems," *IEEE Trans. on Automatic Control*, vol. 38, no. 2, pp. 276-280, 1993.
- [2] G. R. Duan, "Solution to matrix equation  $AV+BW=EVF$  and eigenstructure assignment for descriptor systems," *Automatica*, vol. 28, no. 3, pp. 639-643, 1992.
- [3] G. R. Duan, "Eigenstructure assignment and response analysis in descriptor linear systems with state feedback control," *International Journal of Control*, vol. 69, no. 5, pp. 663-694, 1998.
- [4] G. R. Duan, "Eigenstructure assignment in descriptor linear systems via output feedback," *International Journal of Control*, vol. 72, no. 4, pp. 345-364, 1999.
- [5] M. J. Balas, "Trends in large space structurecontrol theory: Fondest hopes, wildest dreams," *IEEE Trans. on Automatic Control*, vol. 27, no. 3, pp. 522-535, 1982.

- [6] F. Rincon, *Feedback Stabilisation of Second-order Models*, Ph.D. dissertation, Northern Illinois University, De Kalb, Illinois, USA, 1992.
- [7] B. N. Datta and F. Rincon, "Feedback stabilization of a second-order system: A nonmodal approach," *Linear Algebra Applications*, vol. 188, pp. 138-161, 1993.
- [8] A. Bhaya and C. Desoer, "On the design of large flexible space structures (LFSS)," *IEEE Trans. on Automatic Control*, vol. 30, no. 11, pp. 1118-1120, 1985.
- [9] J. N. Juang, K. B. Lim, and J. L. Junkins, "Robust eigensystem assignment for flexible structures," *Journal of Guidance, Control and Dynamics*, vol. 12, no. 3, pp. 381-387, 1989.
- [10] J. Juang and P. G. Maghami, "Robust eigensystem assignment for state estimators using second-order models," *Journal of Guidance, Control and Dynamics*, vol. 15, no. 4, pp. 920-927, 1992.
- [11] E. K. Chu and B. N. Datta, "Numerically robust pole assignment for second-order systems," *International Journal of Control*, vol. 64, no. 4, pp. 1113-1127, 1996.
- [12] D. J. Inman and A. Kress, "Eigenstructure assignment using inverse eigenvalue methods," *Journal of Guidance, Control and Dynamics*, vol. 18, no. 3, pp. 625-627, 1995.
- [13] Y. Kim and H. S. Kim, "Eigenstructure assignment algorithm for mechanical second-order systems," *Journal of Guidance, Control and Dynamics*, vol. 22, no. 5, pp. 729-731, 1999.
- [14] B. N. Datta, S. Elhay, Y. Ram, and D. Sarkissian, "Partial eigenstructure assignment for the quadratic matrix pencil," *Journal of Sound and Vibration*, vol. 230, pp. 101-110, 2000.
- [15] N. K. Nichols and J. Kautsky, "Robust eigenstructure assignment in quadratic matrix polynomials," *SIAM J. Matrix Anal. Appl.*, vol. 23, pp. 77-102, 2001.
- [16] G. R. Duan, and G. P. Liu, "Complete parametric approach for eigenstructure assignment in a class of second-order linear systems," *Automatica*, vol. 38, no. 4, pp. 725-729, 2002.
- [17] G. R. Duan, "Two parametric approaches for eigenstructure assignment in second-order linear systems," *Journal of Control Theory and Applications*, vol. 1, no. 1, pp. 59-64, 2003.
- [18] G. R. Duan, "Parametric eigenstructure assignment in second-order descriptor linear systems," *IEEE Trans. on Automatic Control*, vol. 49, no. 10, pp. 1789-1795, 2004.
- [19] G. R. Duan, "On the solution to the Sylvester matrix equation  $AV + BW = EVF$ ," *IEEE Trans. on Automatic Control*, vol. 41, no. 4, pp. 612-614, 1996.
- [20] A. Laub and W. F. Arnold, "Controllability and observability criteria for multivariate linear second-order models," *IEEE Trans. on Automatic Control*, vol. 29, pp. 163-165, 1984.
- [21] N. F. Almuthairi and S. Bingulac, "On coprime factorization and minimal-realization of transfer-function matrices using the pseudo-observability concept," *International Journal of Systems Science*, vol. 25, no. 27, pp. 1819-1844, 1994.
- [22] T. G. J. Beelen and G. W. Veltkamp, "Numerical computation of a coprime factorization of a transfer-function matrix," *Systems & Control Letters*, vol. 9, no. 4, pp. 281-288, 1987.

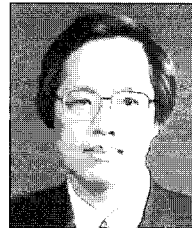

**Guang-Ren Duan** was born in Heilongjiang Province, P. R. China, on April 5, 1962. He received his BSc. degree in Applied Mathematics, and both his MSc and PhD degrees in Control Systems Theory. From 1989 to 1991, he was a post-doctoral researcher at Harbin Institute of Technology, where he became a professor of control systems theory in 1991. Prof. Duan visited the University of Hull, UK, and the University of Sheffield, UK from December 1996 to October 1998, and worked at the Queen's University of Belfast, UK from October 1998 to October 2002. Since August 2000, he has been elected Specially Employed Professor at Harbin Institute of Technology sponsored by the Cheung Kong Scholars Program of the Chinese government. He is currently the Director of the Center for Control Systems and Guidance Technology at Harbin Institute of Technology. He is the author and co-author of over 400 publications. His main research interests include robust control, eigenstructure assignment, descriptor systems, missile autopilot control and magnetic bearing control. Dr Duan is a Chartered Engineer in the UK, a Senior Member of IEEE and a Fellow of IEE.