

Expression of a Recombinant Cry1Ac Crystal Protein Fused with a Green Fluorescent Protein in *Bacillus thuringiensis* subsp. *kurstaki* CryB

Jong Yul Roh, In Hee Lee, Ming Shun Li, Jin Hee Chang, Jae Young Choi, Kyung Saeng Boo and Yeon Ho Je*

School of Agricultural Biotechnology, Seoul National University, Seoul 151-742, Republic of Korea

(Received January 2, 2004 / Accepted September 20, 2004)

To investigate the co-expression and crystallization of a fusion gene between the *Bacillus thuringiensis* crystal protein and a foreign protein in *B. thuringiensis*, the expression of the Cry1Ac fused with green fluorescent protein (GFP) genes in a *B. thuringiensis* CryB strain was examined. The *cry1Ac* gene was cloned in the *B. thuringiensis*-*E. coli* shuttle vector, pHT3101, under the control of the native *cry1Ac* gene promoter, while the GFP gene was inserted into the *Xho*I site upstream of the proteolytic cleavage site, in the middle region of the *cry1Ac* gene (pProAc-GFP). The *B. thuringiensis* CryB strain carrying pProAc-GFP (ProAc-GFP/CB) did not produce any inclusion bodies. However, the transformed strain expressed fusion protein forms although the expression level was relatively low. Furthermore, an immunoblot analysis using GFP and Cry1Ac antibodies showed that the fusion protein was not a single species, but rather multiple forms. In addition, the N-terminal fragment of Cry1Ac and a non-fused GFP were also found in the *B. thuringiensis* CryB strain after autolysis. The sporulated cells before autolysis and the spore-crystal mixture after autolysis of ProAc-GFP/CB exhibited insecticidal activities against *Plutella xylostella* larvae. Accordingly, the current results suggest that a fusion crystal protein produced by the transformant, ProAc-GFP/CB, can be functionally expressed but easily degraded in *B. thuringiensis*.

Key words: *Bacillus thuringiensis*, recombinant, Cry1Ac, GFP, fusion protein

Bacillus thuringiensis strains produce one or more crystal inclusions, which contain one or more insecticidal proteins that are often toxic to a variety of insect species (Kronstad *et al.*, 1983). Generally, most *B. thuringiensis* insecticidal proteins were synthesized during stationary phase and accumulated in the mother cell as a crystal inclusion. The amount of crystal protein accumulated by a *B. thuringiensis* is about 0.5 mg of protein per ml of culture medium and up to 25% of the dry weight of a sporulated cell (Agaïsse and Lereclus, 1995).

The *B. thuringiensis cry1Ac* gene is a typical example of a sporulation-dependent *cry* gene that is only expressed in the mother cell compartment of *B. thuringiensis*. Two overlapping transcription start sites of the *cry1A* gene group, defining two overlapping promoters (BtI and BtII) used sequentially, have been mapped (Wong *et al.*, 1983). In a previous report on the expression efficiency of the *B. thuringiensis* promoter system, the β -galactosidase activity, due to a *cry1Aa-lacZ* fusion, is about 15,000 Miller units on average during sporulation in *B. thuringiensis* (Agaïsse and Lereclus, 1995). This result demonstrated

that these two promoters involved in the *cry1Aa* expression are very strong and could be a very useful tool for the expression of foreign proteins with specific functions (e.g. insecticidal activity or synergistic effects).

Concerning the enhancement of the toxicity of *B. thuringiensis* as insecticides, some researchers have already attempted to express foreign protein genes, such as chitinase and *B. sphaericus* binary toxin, as fusion protein forms with a crystal protein in *B. thuringiensis* strains for increasing mosquitocidal activity (Li *et al.*, 2000; Sirichotpakorn *et al.*, 2001). For example, the co-application of commercial chitinase preparations with *B. thuringiensis* subsp. *israelensis* toxin enhances the larvicidal activity of this bacterium (Lysenko, 1976; Morris, 1976). However, when using the co-expression of chitinase together with Cry11A under the *cry11A* promoter in *B. thuringiensis* 4Q2-72, there is no significant increase of toxicity although the co-application resulted in decreased LC₅₀ values (Sirichotpakorn *et al.*, 2001). They suggested that the reason why the toxicity was not increased might be due to the soluble expression of chitinase. It resulted in no-assembly of the chitinase into the crystal inclusion body, so a soluble chitinase produced by recombinant strains might be diluted into a culture media at an insufficient concentration.

* To whom correspondence should be addressed.
(Tel) 82-2-880-4706; (Fax) 82-2-878-4706
(E-mail) btrus@snu.ac.kr

Accordingly, in the current study, to verify the co-expression and crystallization of a fusion gene between the *B. thuringiensis* Cry1 type-crystal protein and a foreign protein in *B. thuringiensis*, the *cry1Ac* gene was fused with a green fluorescent protein (GFP) gene as a model. Our study of a transformant harboring the Cry protein-GFP fusion construct investigated the fusion expression and the larvicidal effect against *Plutella xylostella* larvae. The objective of this study was to determine whether a coproduction of a foreign protein and a crystal protein would produce fusion crystals and affect the original efficacy of an insecticidal crystal protein as a fundamental study.

Materials and Methods

Bacterial strains and culture media

E. coli XL1-Blue strain was used as the host for transformation and amplification of the recombinant plasmids. *B. thuringiensis* subsp. *kurstaki* CryB (CryB) was used as the host for the expression of the fusion protein and *B. thuringiensis* subsp. *kurstaki* HD-73 (HD-73) as the positive control strain. *B. thuringiensis* cultures were grown at 30°C with vigorous shaking in the SPY (Spizizen medium) medium for the plasmid preparation and in the GYS (Glucose-yeast extract salt medium) medium for the expression of the fusion protein. The spore yields were checked using a colony count and the data were evaluated by standard statistical procedures.

Plasmids and oligonucleotides

The GFP gene (derived from the jelly fish, *Aequorea vic-*

toria; Chalfie *et al.*, 1994) was amplified from the plasmid pGFP (Clontech Co., USA) using *Xho*I-linked PCR primers of GF (GFP forward, 5'-TACTCGAGATGAGTAAAGGAGAAGAA-3') and GR (GFP reverse, 5'-CTCTC-GAGTTTGTATAGTTCCATCCA-3'). For the expression of the *B. thuringiensis* fusion crystal protein, the GFP PCR product, after digestion with *Xho*I, was inserted into the *Xho*I site of pProAc (Roh *et al.*, 2000) and named pProAc-GFP. The fusion gene, pProAc-GFP, had the promoter, ribosomal binding site and the terminator of the *cry1Ac* gene (Fig. 1).

PCR

For amplification of the GFP fragment, a PCR was performed with *Pyrobest*TM DNA polymerase (Takara Co., Japan) using a DNA Thermal Cycler (Perkin Elmer Co., USA) based on a 30-cycle program, with each cycle consisting of denaturation at 98°C for 10 sec, annealing at 55°C for 30 sec, and extension at 72°C for 1 min. Other PCR amplifications were also conducted with *Taq* DNA polymerase in a PreMix[®]-Top (Bioneer Co., Korea) based on a 35-cycle program of denaturation at 94°C for 1 min, annealing at 55°C for 1 min, and extension at 72°C for 1 min. To confirm the fusion gene in the CryB transformant, 1Ac (*cry1Ac* specific forward, 5'-TCACTTCCC-ATCGACATCTACC-3') and 13 (*cry1* type-conserved region reverse, 5'-ATCACTGAG-TCGCTTCGCATGTT-TGACTTTCTC-3') primers as well as the GF and GR primers were used.

Electroporation

Electroporation was performed according to the method of

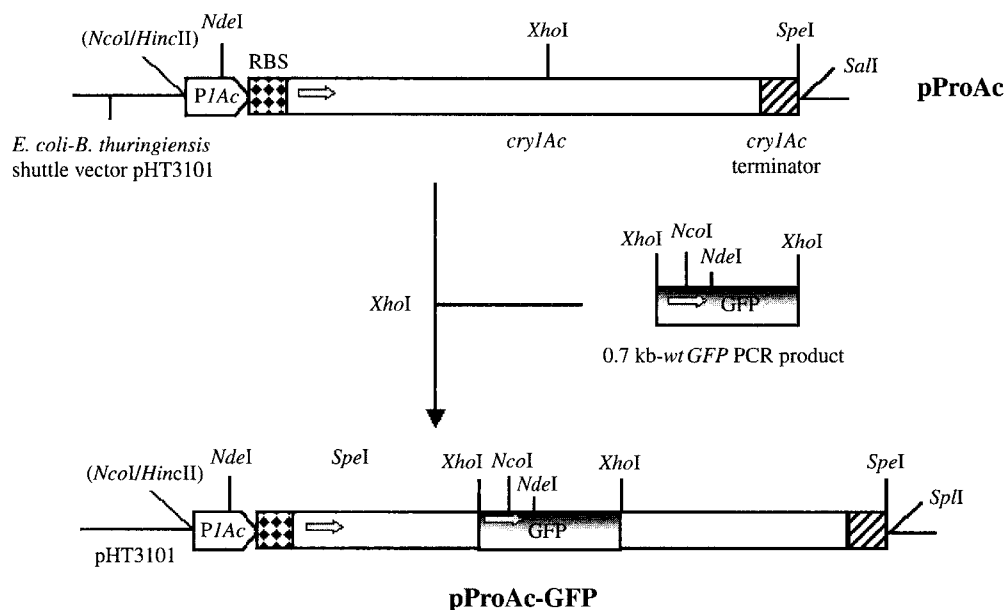

Fig. 1. Construction of a pProAc-GFP vector. pProAc-GFP contains a *cry1Ac* coding region (open box), ribosomal binding sequence (RBS, dotted box), and a terminator (lined box) by incorporating the GFP gene without its stop codon. The open arrowhead in each plasmid drawing indicates the reading orientation of the *cry1Ac* and the GFP gene.

Lereclus *et al.* (1989), with a slight modification. *B. thuringiensis* cells were grown to an OD₆₀₀ of 1 in 100 ml of a Brain Heart Infusion (BHI, BD diagnostic systems, USA) with shaking at 30°C. The cells were harvested and washed once in 10 ml of cold distilled water. The pellet was then resuspended in 4 ml of cold sterile polyethylene-glycol (PEG) 6000 (40%, w/v). Thereafter, cell aliquots of 0.4 ml were mixed with the plasmid DNA in 0.2 cm electroporation cuvettes (Bio-Rad Co., USA) at 4°C. A Bio-Rad Gene Pulser apparatus was set at 25 µF and 2.5 kV, and the pulse controller was set to 400 Ω. The cuvette was placed in the safety chamber and the pulse was applied once. Following electroporation, the cells were diluted in 2 ml of a pre-warmed BHI medium and incubated for 2 h at 30°C. After this expression period, the cells were then plated on a nutrient agar medium (BD diagnostic systems, USA) supplemented with erythromycin (25 g/ml) for growth and sporulation.

SDS-PAGE and immunoblot analysis

The *B. thuringiensis* strains were grown in GYS media and then sporulated cells were collected after 36 h (sporulated cell before autolysis) and spore-crystal mixtures after autolysis were collected after 96 h. The sporulated cells, spores, and crystal proteins were treated as SDS-PAGE samples and SDS-PAGE was performed on a 12% polyacrylamide separating gel with a 3% stacking gel.

For an immunoblot analysis, the Cry1Ac antibody raised against Cry1Ac crystals from the HD-73 strain, and rabbit GFP antibody (Clontech Co., USA) were used. The GFP antibody was then detected with a second antibody conjugated to alkaline phosphatase, which was allowed to show a chromogenic reaction based on the addition of 5-bromo-4-chloro-3-indolyl phosphate disodium salt/nitro blue tetrazolium (BCIP/NBT). The Cry1Ac antibody was

detected with a second antibody conjugated to horseradish peroxidase and ECL Western blotting detection reagents (Amersham biosciences, UK).

Bioassay on *Plutella xylostella* larvae

In the case of the CryB strain transformed with pProAc-GFP, bioassays were performed on the third instar larvae of *P. xylostella* with two preparations, sporulated cells and spore-crystal mixtures. Thirty larvae were applied to each treatment. The tested larvae were reared at 25°C and 60% humidity. The treatment dosages were diluted using a log scale from 1×10⁸ CFU per cm² of Chinese cabbage leaf (2×2 cm²) and each treatment was repeated three times. Mortality was calculated by counting the dead larvae after 24 h, and the median lethal concentration was calculated using a Probit analysis (Russell *et al.*, 1977).

Results

Construction and electroporation of recombinant plasmids for fusion proteins with GFP and the cry1Ac gene

To construct a fusion gene for the expression of a foreign protein, a GFP gene without its stop codon was introduced into the *Xho*I site of the *cry1Ac* gene of pProAc (named as pProAc-GFP). An outline describing the generation of the recombinant plasmid is shown in Fig. 1. The promoter region, ribosomal binding site, and terminator regions of pProAc came from HD-73 containing only the *cry1Ac* gene. The vector construction of pProAc-GFP was confirmed with restriction endonuclease analysis and DNA sequencing.

The recombinant plasmid, pProAc-GFP, was extracted from the *E. coli* XL1-Blue strain and electroporated into the crystal-negative strain, CryB. The presence of a recombinant plasmid in the strain CryB after electroporation was confirmed by a PCR with a set of oligonucleotide primers to detect the presence of the GFP gene and the *cry1Ac* gene (Fig. 2). The expected PCR products were detected in the transformant (Fig. 2B). The CryB transformant harboring pProAc-GFP was named ProAc-GFP/CB.

Expressions of a fusion protein in *B. thuringiensis*

The ProAc-GFP/CB transformant did not produce any parasporal inclusions when it was observed by phase contrast microscopy during sporulation. The expression of the fusion protein gene in the ProAc-GFP/CB cells was analyzed by SDS-PAGE and an immunoblot analysis. In SDS-PAGE, the fusion protein and the other (N-terminal of *cry1Ac* or GFP) bands of the ProAc-GFP/CB transformant were simultaneously absent in the cell samples before autolysis and spore-crystal mixture after autolysis, but HD-73 and ProAc/CB exhibited a 130 kDa Cry1Ac protein band (Fig. 3A). However, the immunoblot analysis using a Cry1Ac antibody identified a weak band of the

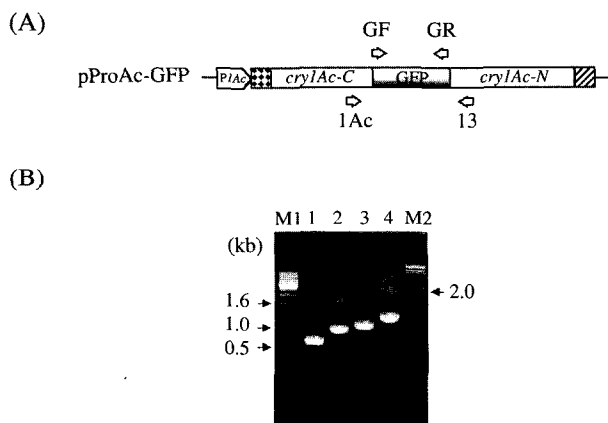

Fig. 2. Structure of pProAc-GFP (A) and an electrophoresis pattern of the PCR products of a *B. thuringiensis* CryB strain transformed with pProAc-GFP. A: binding sites of primers shown. B: PCR products from GF and GR (lane 1), GF and 13 (lane 2), 1Ac and GR (lane 3) and, 1Ac and 13 (lane 4). M1 and M2 indicate a 1 kb DNA ladder (Bioneer Co.) and lambda DNA digested with *Hind*III, respectively.

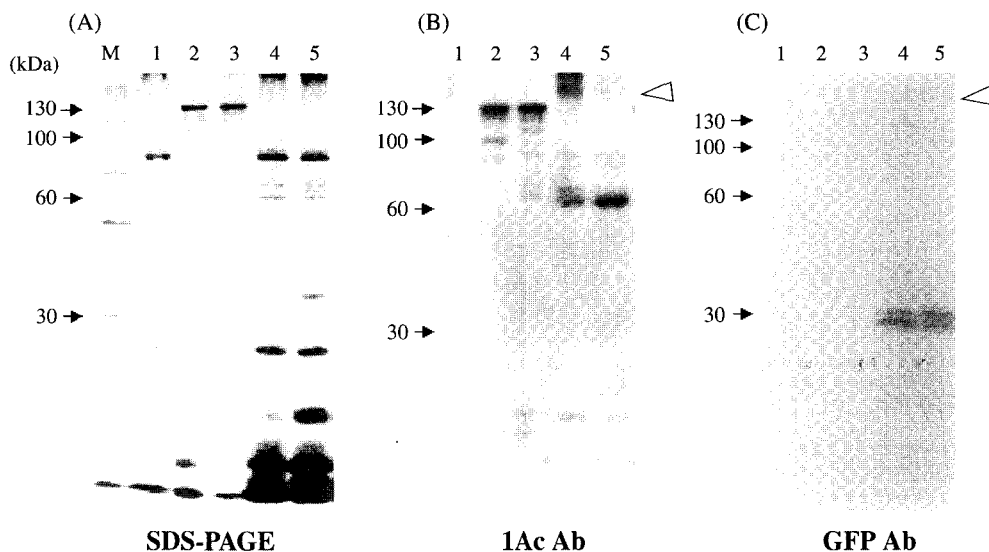

Fig. 3. SDS-PAGE (A) and Immunoblot analysis using Cry1Ac (B) and GFP (C) antibodies. Lane 1: CryB; 2: HD-73; 3: ProAc/CB; 4: cells before autolysis of ProAc-GFP/CB; 5: cells after lysis of ProAc-GFP/CB; M: a 10 kDa protein ladder (Difco Co.). An arrowhead indicates Cry1Ac (A) or multiple forms of the fusion proteins of ProAc-GFP/CB (B and C).

full fusion protein, a 67 kDa N-terminal of the Cry1Ac band, and several weak bands, which were apparently the degradation products of the fusion protein (Fig. 3B). In the case of detection with the GFP antibody, GFP itself, GFP plus the remains of Cry1Ac, and several degradation forms were also found (Fig. 3C). A full-sized band was detected in the sporulated cell samples before autolysis though this signal was very weak.

Spore production and insecticidal activity of recombinant *B. thuringiensis* strains

To compare the growth of the recombinants producing the fusion protein, each strain was cultured in the GYS medium for 24 h. The two transformants and CryB produced about 80-90% of the spores produced by the wild type, HD-73 (Table 1). This result showed an identical tendency with a report that stated the introduction of a high-copy-number plasmid into a *B. thuringiensis* host probably results in a reduction in sporulation that in turn, affects toxin synthesis (Sirichotpakorn *et al.*, 2001).

The insecticidal activity of the crystal proteins produced by the ProAc-GFP/CB transformant was evaluated against *P. xylostella* larvae and compared with those of HD-73

and ProAc/CB from two different period cell samples, before autolysis and after autolysis (Table 2). Because we could not observe a recombinant inclusion form by phase contrast microscopy and most recombinant proteins existed as a soluble form, we divided protein samples into two phases based on autolysis. Overall, the median lethal concentration (LC₅₀) after autolysis was slightly higher than that of the sporulated cells. The LC₅₀ of the ProAc-GFP/CB transformant was 3-5 times higher in the sporulated cells, yet 10-15 times higher in the spore-crystal mixtures when compared to that of HD-73 or ProAc/CB. However, the crystal protein produced by the ProAc-GFP/

Table 1. Relative efficiency of spore production of the wild-type (HD-73) and transformed *Bacillus thuringiensis* strains in GYS

Strain	No. (of × 10 ⁶ CFU/ml)	SD (±)
HD-73	232.33a*	10.69
CryB	186.00b	15.39
ProAc/CB	212.00ab	17.58
ProAc-GFP/CB	194.00b	16.64

*Numbers with the same letter shows no significant difference by the Duncan's multiple range test (α = 0.05).

Table 2. Insecticidal activities of sporulated cells before autolysis and of a spore-crystal mixture after autolysis of *B. thuringiensis* transformants against the third instar larvae of *P. xylostella*

Strain	Sporulated cells before autolysis		Spore-crystal mixture after autolysis	
	LC ₅₀ *	95% fiducial limits	LC ₅₀	95% fiducial limits
HD-73	16.95	8.25–35.08	21.27	8.45 – 57.57
CryB	> 2,500.00	–	> 2,500.00	–
ProAc/CB	25.56	10.41–69.84	30.50	13.24 – 71.12
ProAc-GFP/CB	72.54	29.51–229.75	202.60	75.61 – 632.72

*All median lethal concentrations are presented as ×10⁴ CFU/cm².

CB transformant was still functional in killing the *P. xylostella* larvae. Accordingly, these results suggest that the N-terminal toxic domain of CryIAc, GFP, and other fusion forms existed in the sporulated cells and the toxic domain among them exhibited insecticidal activity towards *P. xylostella* larvae.

Discussion

Until now, studies on the expression of *B. thuringiensis* crystal proteins have mainly concentrated on two areas. The first is their expression in adaptable hosts, such as a leaf or a root-colonizing bacterium or plant against target pest insects (Stock *et al.*, 1990; Strizhov *et al.*, 1996), while the second is the overproduction of crystal proteins per cell through an overexpression in *B. thuringiensis* cells (Lereclus *et al.*, 1995; Park *et al.*, 1998). Therefore, in contrast to previous reports, this study focused on the possibility of expressing *B. thuringiensis* crystal proteins fused with other insecticidal proteins or proteins containing synergistic effects. Thus, we aimed to co-express a CryIAc-GFP fusion protein as a model system. This co-expression and crystallization of the *B. thuringiensis* crystal protein and others in a parasporal inclusion could have significant effects on insecticidal activity and possibly delay the development of insect resistance.

To construct a fusion gene comprised of the *cryIAc* and the GFP gene, the GFP gene was inserted into the *XhoI* site in the middle region of the *cryIAc* gene. This site is located at residue 612 (Leu) and 613 (Glu) and also in front of the predicted proteolytic cleavage site, residue 623 (Lys) (Schnepf *et al.*, 1985; Schnepf *et al.*, 1998). Furthermore, Adang *et al.* (1985) previously expressed a functionally truncated CryIAc protein using the *XhoI* site between residue 612 (Leu) and 613 (Glu). Therefore, it was considered that such a scheme would conserve the inherent N-terminal toxic domain and the functional foreign protein upon ingestion by insect larvae.

The current results confirm that the fusion protein was expressed in the *B. thuringiensis* cells although it was apparently quickly degraded. Moreover, in contrast to the case of ProAc/CB, ProAc-GFP/CB did not produce any typical parasporal inclusions before autolysis when it was observed by phase-contrast microscopy. Possible reasons for this degradation may have been due to the instability of the fusion protein and the existence of a variety of proteolytic enzymes against foreign proteins in the cytoplasm of *B. thuringiensis*. First, the expressed full-size fusion protein may have been very degradable at an early stage of the expression and this may have resulted in failure of accumulation of the fusion protein and crystallization of the recombinant parasporal inclusion. Second, the expression of a foreign protein in *B. thuringiensis* cells may have interfered with numerous endogenous proteases of *B. thuringiensis*. Proteases endogenous to the bacterium have

been described from the cysteine, metallo and serine families of enzymes (Oppert, 1999). *B. thuringiensis* protease may degrade crystal proteins and affect insect toxicity. Resulting from these reasons, the recombinant *B. thuringiensis* strain may have failed to accumulate massive crystal proteins in the protease-resistant inclusion bodies in the sporulated cells. The failure to observe GFP in the cytoplasm, based on irradiation by near UV, may have been the reason why the GFP gene was not bright enough to be observed in the prokaryotic cells (Lewis *et al.*, 1999).

Future studies will focus on the merits of *B. thuringiensis* recombinant crystals that can be expressed and massively accumulated as a foreign insecticidal protein in parasporal inclusions. Furthermore, the production of multiple-functional recombinant proteins through the construction of a fusion system is expected to increase insecticidal activity or delay insect resistance development. It is still unknown whether a fusion protein can be expressed in a protease-deficient *Bacillus* strain (Kawamura *et al.*, 1984); therefore, this possibility is also currently under evaluation. Additionally, we will try various type-fusion manners between a Cry protein and a foreign protein.

Acknowledgement

This work was supported by the Brain Korea 21 Project.

References

- Adang, M.J., M.J. Staver, T.A. Rocheleau, J. Leighton, R.F. Barker, and D.V. Thompson. 1985. Characterized full-length and truncated plasmid clones of the crystal protein of *Bacillus thuringiensis* subsp. *kurstaki* HD-73 and their toxicity to *Manduca sexta*. *Gene* 36, 289-300.
- Agaisse, H. and D. Lereclus. 1995. How does *Bacillus thuringiensis* produce so much insecticidal crystal protein? *J. Bacteriol.* 177, 6027-6032.
- Chalfie, M., Y. Tu, G. Euskirchen, W.W. Ward, and D.C. Prasher. 1994. Green fluorescent protein as a marker for gene expression. *Science* 263, 802-805.
- Kawamura, F. and R.H. Doi. 1984. Construction of a *Bacillus subtilis* double mutant deficient in extracellular alkaline and neutral proteases. *J. Bacteriol.* 160, 442-444.
- Kronstad, J.W. and H.R. Whiteley. 1986. Three classes of homologous *Bacillus thuringiensis* crystal protein genes. *Gene* 43, 29-40.
- Lereclus, D., H. Agaisse, M. Gominet, and J. Chaufaux. 1995. Overproduction of encapsulated insecticidal crystal proteins in a *Bacillus thuringiensis* *spoOA* mutant. *BioTechnology* 13, 67-71.
- Lereclus, D., O. Arantes, J. Chaufaux, and M.M. Lecadet. 1989. Transformation and expression of a cloned δ -endotoxin gene in *Bacillus thuringiensis*. *FEMS Microbiol. Lett.* 60, 211-218.
- Lewis, P.J. and A.L. Marston. 1999. GFP vectors for controlled expression and dual labeling of protein fusions in *Bacillus subtilis*. *Gene* 227, 101-109.

- Li, T., F. Sun, Z. Yuan, Y. Zhang, J. Yu, and Y. Pang. 2000. Coexpression of *cyt1Aa* of *Bacillus thuringiensis* subsp. *israelensis* with *Bacillus sphaericus* binary toxin gene in acrySTALLIFEROUS strain of *B. thuringiensis*. *Curr. Microbiol.* 40, 322-326.
- Lysenko, O. 1976. Chitinase of *Serratia marcescens* and its toxicity to insects. *J. Invertebr. Pathol.* 27, 385-386.
- Morris, O.N. 1976. A two year study of the efficacy of *Bacillus thuringiensis*-chitinase combinations in spruce budworm (*Choristoneura fumiferana*) control. *Can. Entomol.* 108, 3225-3233.
- Oppert, B. 1999. Protease interactions with *Bacillus thuringiensis* insecticidal toxins. *Arch. Insect Biochem. Physiol.* 42, 1-12.
- Park, H.W., B. Ge, L.S. Bauer, and B.A. Federici. 1998. Optimization of Cry3A yields in *Bacillus thuringiensis* by use of sporulation-dependent promoters in combination with the STAB-SD mRNA sequence. *Appl. Environ. Microbiol.* 64, 3932-3938.
- Roh, J.Y., I.H. Lee, J.H. Li, M.S. Li, H.S. Kim, Y.H. Je, and K.S. Boo. 2000. Expression of the *cryIAc1* gene under the control of the native or the α -amylase promoters in an acrySTALLIFEROUS *Bacillus thuringiensis* strain. *Int. J. Indust. Entomol.* 1, 123-129.
- Russell, R.M., J.L. Robertson, and S.E. Sauvin. 1977. POLO: A new computer program for probit analysis. *Bull. Entomol. Soc. Am.* 23, 209-213.
- Schnepf, E., N. Crickmore, J. Van Rie, D. Lereclus, J. Baum, J. Feitelson, D. R. Zeigler, and D.H. Dean. 1998. *Bacillus thuringiensis* and its pesticidal crystal proteins. *Microbiol. Mol. Biol. Rev.* 62, 775-806.
- Schnepf, H.E. and H.R. Whiteley. 1985. Delineation of a toxin-encoding segment of a *Bacillus thuringiensis* crystal protein gene. *J. Biol. Chem.* 260, 6273-6280.
- Sirichotpakorn, N., P. Rongnoparut, K. Choosang, and W. Panbangred. 2001. Coexpression of chitinase and the *cryIIAa1* toxin genes in *Bacillus thuringiensis* serovar *israelensis*. *J. Invertebr. Pathol.* 78, 160-169.
- Stock, C.A., T.J. McLoughlin, J.A. Klein, and M.J. Adang. 1990. Expression of a *Bacillus thuringiensis* crystal protein in *Pseudomonas cepacia* 526. *Can. J. Microbiol.* 36, 879-884.
- Strizhov, N., M. Keller, J. Mathur, Z. Koncz-Kalman, D. Bosch, E. Prudovsky, J. Schell, B. Sneh, C. Koncz, and A. Zilberstein. 1996. A synthetic *cryIC* gene, encoding a *Bacillus thuringiensis* δ -endotoxin, confers *Spodoptera* resistance in alfalfa and tobacco. *Proc. Natl. Acad. Sci. USA.* 93, 15012-15017.
- Wong, H.C., H.E. Schnepf, and H.R. Whiteley. 1983. Transcriptional and translational start sites for the *Bacillus thuringiensis* crystal protein gene. *J. Biol. Chem.* 258, 1960-1967.