

## A Simple Nonlinear Control of a Two-Wheeled Welding Mobile Robot

Trong Hieu Bui, Tan Tien Nguyen, Tan Lam Chung, and Sang Bong Kim

**Abstract:** This paper proposes a simple, robust, nonlinear controller based on Lyapunov stability for tracking the reference welding path and velocity of a two-wheeled welding mobile robot (WMR). The system has three degrees of freedom including two wheels and one torch slider. Torch slider motion is used for faster tracking because the welding speed is very slow. Control law is obtained from the Lyapunov control function to ensure the asymptotical stability of the system. The controller has three free parameters for adjusting the performance of the controlled system. A simple way of measuring the errors using two potentiometers is introduced. The effectiveness of the proposed controller is shown through simulation results.

**Keywords:** Welding mobile robot (WMR), tracking, welding path reference.

### 1. INTRODUCTION

Today, the welding process is strongly encouraged for improvements in quality, productivity and labor conditions. In naval construction, the automation welding process is ultimately necessary, since the welding sites are spatially enclosed by floors and girders and the welders are exposed to severe working conditions. To solve this problem, some robotic welding systems have recently been developed. Santos et al. [11] developed the ROWER system, a complex, four-legged, mobile platform welding machine, for application in the naval construction process. Kim et al. [7] proposed a system of visual sensing and welding environment recognition, for intelligent shipyard welding robots. Jeon et al. [4] and Kam et al. [6] proposed a simple welding mobile robot (WMR) for lattice-type of welding. The WMR combines a platform of a two-wheeled mobile robot and a torch slider that carries the welding electrode, so the WMR has properties of a two-wheeled mobile robot.

A mobile robot is one of the well-known systems

with non-holonomic constraints, and many works on tracking control methods for mobile robots are available in the literature. Kanayama et al. [5] proposed a stable tracking control method for a non-holonomic vehicle using the Lyapunov function in which the error configuration is defined and the error dynamics are used for deriving the controller. Sarkar et al. [12] proposed a nonlinear feedback that guarantees input-output stability and Lagrange stability for the overall system. Fierror [1] developed a combined kinetic/torque control law using a back-stepping approach. Zeng and Moore [16] dealt with time-optimal control strategies for mobile robots to track a moving target with the Pontryagin maximum principle. Yun and Sarkar [15] focused on kinematics and control of a vehicle with two steerable wheels using a dynamic feedback linearization. Mukherjee et al. [10] proposed an asymptotic feedback stabilization of a non-holonomic mobile robot using a nonlinear oscillator. Taybei [13] presented a back-stepping procedure for the design of discontinuous, time-invariant, state feedback controllers for the stabilization of non-holonomic systems and an exponentially stabilizing adaptive controller for conditions in which inputs disturbances exist. Tsuchia et al. [14] designed a controller based on the kinematic model by extending the Lyapunov control. Fukao et al. [2] dealt with the adaptive tracking control of a two-wheeled mobile robot. An adaptive law was proposed for updating the error of unknown parameters. Lee et al. [9] used a saturation feedback controller for tracking control of a unicycle-modeled mobile.

Jeon et al. [3] applied the two-wheeled mobile robot for welding automation. Jeon proposed a seam-tracking and motion control of WMR for lattice-type welding. Three controllers were available for control-

Manuscript received February 4, 2002; accepted July 4, 2002.

Trong-Hieu Bui is with the Department of Mechanical Engineering, College of Eng., Pukyong National University, Korea. (e-mail: hieupknu@yahoo.com.).

Tan-Tien Nguyen is with the Department of Mechanical Engineering, Hochiminh City University of Technology, Vietnam. (e-mail: tiennt@yahoo.com).

Tan-Lam Chung is with the Department of Mechanical Engineering, College of Eng., Pukyong National University, Korea. (e-mail: chungtanlam@yahoo.com).

Sang-Bong Kim is with the Department of Mechanical Engineering, College of Eng., Pukyong National University, Korea. (e-mail: kimsb@mail.pknu.ac.kr).

ling, straight and turning locomotion and the torch slider. Kam proposed a control algorithm for straight welding based on "trial and error" method in each step time. The seam-tracking sensor moves together with the torch slider. If there is an "error," the controller will adjust the WMR motion based on pre-programmed schedule. The controllers are used only for straight-line tracking and cannot be extended for a smooth, curved-line tracking. Both controllers proposed by Jeon and Kam have been successfully applied for real systems, but both controllers are complex and experience loss of generality when allying for general, smooth path tracking.

This paper proposes a simple nonlinear controller based on the Lyapunov control function to enhance the tracking properties of the WMR. To design a tracking performance, an error configuration is defined and the controller is designed to drive the error to zero as fast as desired. The controlled system attains Lyapunov stability. To design a controller, a simple method for measuring the errors using potentiometers is proposed. Two cases are considered: fixed torch and controlled torch WMRs. The WMR has a geometrical property: the welding point is outside its wheels and is far from its center. This property leads to the slow convergence of tracking errors in the case of a fixed torch WMR. This disadvantage can be overcome by using a controlled torch slider. The simulation for a WMR with a straight welding path shows the effective-ness of the proposed controller.

**2. SYSTEM MODELING**

The WMR used in this paper is the MR-SL model which was developed by CIMEC Lab., Pukyong National University, and was used for Jeon and Kam's works et al.[6] The model is presented in Fig.1. This WMR model was originally developed to automatically weld the straight-line but with an appropriate controller, as shown in this paper, it can be used for welding a smooth curved line. By including the welding torch motion into the system dynamics, the welding robot can track the reference path and welding speed well.

We assume that the wheels roll and avoid slipping. The kinematic equation of the WMR and the relation of its coordinates with its reference welding path are shown in Fig. 2. The ordinary form of a mobile robot with two actuated wheels can be derived as follows

$$\begin{bmatrix} \dot{x} \\ \dot{y} \\ \dot{\phi} \end{bmatrix} = \begin{bmatrix} \cos \phi & 0 \\ \sin \phi & 0 \\ 0 & 1 \end{bmatrix} \begin{bmatrix} v \\ \omega \end{bmatrix}, \tag{1}$$

where  $C(x, y)$  is the Cartesian coordinate of the WMR's center point,  $\phi$  is the heading angle of the

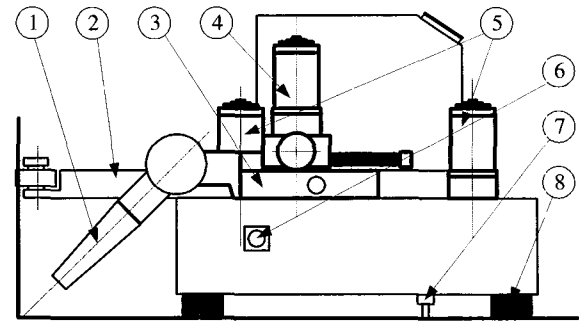

- ① welding torch
- ② sensor
- ③ torch slider
- ④ torch-sliding driving motor
- ⑤ wheel-driving motors
- ⑥ proximity sensor
- ⑦ lower limit switch
- ⑧ driving wheels

Fig. 1. WMR configuration.

WMR, and  $v$  and  $\omega$  are the straight and angular velocities of the WMR at its center point

The relationship between  $v$ ,  $\omega$  and the angular velocities of the two driving wheels is

$$\begin{bmatrix} \omega_{rw} \\ \omega_{lw} \end{bmatrix} = \begin{bmatrix} 1/r & b/r \\ 1/r & -b/r \end{bmatrix} \begin{bmatrix} v \\ \omega \end{bmatrix}, \tag{2}$$

where  $\omega_{rw}$ ,  $\omega_{lw}$  represent the angular velocities of the right and left wheels,  $b$  is the distance from the WMR's center point to the driving wheel, and  $r$  is driving wheel radius. The welding point coordinates,  $W(x_w, y_w)$ , and the heading angle,  $\phi_w$ , can be calculated from the WMR's center point:

$$\begin{cases} x_w = x - l \sin \phi, \\ y_w = y + l \cos \phi, \\ \phi_w = \phi. \end{cases} \tag{3}$$

Hence, we have

$$\begin{cases} \dot{x}_w = v \cos \phi - l \omega \cos \phi - \dot{l} \sin \phi, \\ \dot{y}_w = v \sin \phi - l \omega \sin \phi + \dot{l} \cos \phi, \\ \dot{\phi}_w = \omega. \end{cases} \tag{4}$$

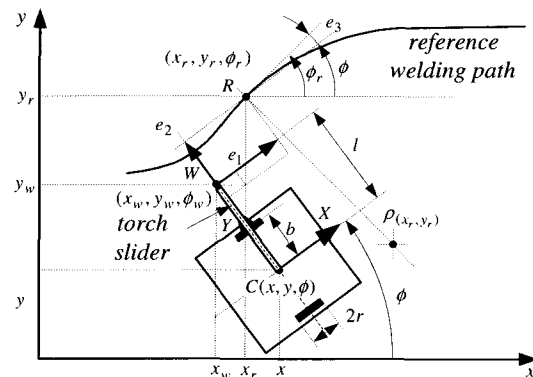

Fig. 2. Scheme for deriving the kinematic equations of WMR.

A reference point,  $R(x_r, y_r)$ , moving with the constant velocity of  $v_r$  on the reference path, has the coordinates  $(x_r, y_r)$ , and the heading angle,  $\phi_r$ , satisfies the dynamic equation

$$\begin{cases} \dot{x}_r = v_r \cos \phi_r, \\ \dot{y}_r = v_r \sin \phi_r, \\ \dot{\phi}_r = \omega_r, \end{cases} \quad (5)$$

where  $\phi_r$  is defined as the angle between  $\bar{v}_r$  and  $x$  coordinates and  $\omega_r$  is the rate of change of  $\bar{v}_r$  direction.

### 3. CONTROLLER DESIGN

Our objective is to design a controller so that the welding point  $W$  tracks to the reference point  $R$ . We define the tracking errors  $e = [e_1, e_2, e_3]^T$ , as shown in Fig. 2, as

$$\begin{bmatrix} e_1 \\ e_2 \\ e_3 \end{bmatrix} = \begin{bmatrix} \cos \phi & \sin \phi & 0 \\ -\sin \phi & \cos \phi & 0 \\ 0 & 0 & 1 \end{bmatrix} \begin{bmatrix} x_r - x_w \\ y_r - y_w \\ \phi_r - \phi_w \end{bmatrix}. \quad (6)$$

We will design a controller to achieve  $e_i \rightarrow 0$  when  $t \rightarrow \infty$ , and hence the welding point  $W$  tracks to its reference point  $R$ . We will consider two cases: using and omitting the torch slider.

#### 3.1. Fixed torch length

In this case, the torch is adjusted only before welding. Angular velocities of the left wheel and the right wheel are the two inputs to the system. When torch length  $l$  is constant, from Eqs. (1, 3-6), we can confirm that  $\dot{e}_i$  satisfies

$$\begin{bmatrix} \dot{e}_1 \\ \dot{e}_2 \\ \dot{e}_3 \end{bmatrix} = \begin{bmatrix} v_r \cos e_3 \\ v_r \sin e_3 \\ \omega_r \end{bmatrix} + \begin{bmatrix} -1 & e_2 + l \\ 0 & -e_1 \\ 0 & -1 \end{bmatrix} \begin{bmatrix} v \\ \omega \end{bmatrix}. \quad (7)$$

The chosen Lyapunov function and its derivative are given as

$$V_c = \frac{1}{2}e_1^2 + \frac{1}{2}e_2^2 + \frac{1 - \cos e_3}{k_2}, \quad (8)$$

$$\begin{aligned} \dot{V}_c &= e_1 \dot{e}_1 + e_2 \dot{e}_2 + \frac{\sin e_3}{k_2} \dot{e}_3 \\ &= e_1(-v + l\omega + v_r \cos e_3) + \frac{\sin e_3}{k_2}(-\omega + \omega_r + k_2 e_2 v_r). \end{aligned} \quad (9)$$

An obvious way to achieve negativity of  $\dot{V}_c$  is to choose  $(v, \omega)$  as

$$\begin{cases} v = l(\omega_r + k_2 e_2 v_r + k_3 \sin e_3) + v_r \cos e_3 + k_1 e_1, \\ \omega = \omega_r + k_2 e_2 v_r + k_3 \sin e_3, \end{cases} \quad (10)$$

where  $k_1, k_2, k_3$  are positive values. The controller in Eq. (10) is good for deriving the errors as  $e_i \rightarrow 0$  ( $i=1,2,3$ ) only when the reference velocity  $v_r$  is large enough. In our application, the reference welding speed  $v_r$  is usually very low (about  $7.5 \times 10^{-3} m/s$ ), so that the error  $e_2$  slowly converges to zero. This problem can be seen from Fig. 2: with the geometrical structure of the WMR, the welding point lies out of the two wheels and far from the WMR's center. As a result, only the errors  $e_1$  and  $e_3$  easily to converge to zeros. The slow convergence of error  $e_2$  can be avoided by using a controlled torch slide.

#### 3.2. Controlled torch length

In this case, the torch is adjusted during welding. The linear velocity of the torch slider is an additional system input. The configuration of the torch slider is given in Fig. 3. When the torch slider is used, the torch length  $l$  is changeable. (7) is rewritten as

$$\begin{bmatrix} \dot{e}_1 \\ \dot{e}_2 \\ \dot{e}_3 \end{bmatrix} = \begin{bmatrix} v_r \cos e_3 \\ v_r \sin e_3 - \dot{l} \\ \omega_r \end{bmatrix} + \begin{bmatrix} -1 & e_2 + l \\ 0 & -e_1 \\ 0 & -1 \end{bmatrix} \begin{bmatrix} v \\ \omega \end{bmatrix}. \quad (11)$$

Now the Lyapunov function is chosen as

$$V_l = \frac{1}{2}e_1^2 + \frac{1}{2}e_2^2 + \frac{1}{2}e_3^2 \geq 0 \quad (12)$$

and its derivative is

$$\begin{aligned} \dot{V}_l &= e_1 \dot{e}_1 + e_2 \dot{e}_2 + e_3 \dot{e}_3 \\ &= e_1(-v + l\omega + v_r \cos e_3) + e_2(v_r \sin e_3 - \dot{l}) \\ &\quad + e_3(-\omega + \omega_r). \end{aligned} \quad (13)$$

To achieve the negativity of  $\dot{V}_l$ , we choose  $(v, \omega)$  as

$$\begin{cases} v = l(\omega_r + k_3 e_3) + v_r \cos e_3 + k_1 e_1, \\ \omega = \omega_r + k_3 e_3, \end{cases} \quad (14)$$

and the torch length  $l$  satisfies

$$\dot{l} = v_r \sin e_3 + k_2 e_2. \quad (15)$$

From Eqs. (2) and (10) or Eq. (14), we can calculate the necessary velocities of the two driving wheels  $\omega_{rw}$  and  $\omega_{hw}$ .

### 4. MEASUREMENT OF THE ERRORS

In the mobile robot control problem, environment information is very important for robot operation.

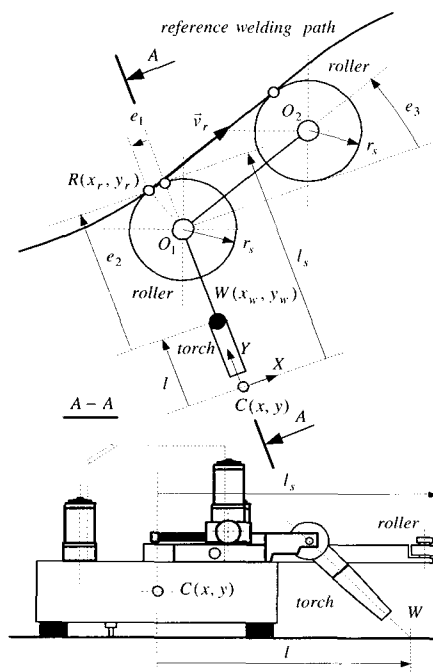

Fig. 3. Scheme for measuring the errors.

Of the two types of unknown and known environments, our application belongs to the first type: the WMR follows an unknown smooth curved steel wall to do its lattice-type of welding. For the WMR's operation, first the free space around the WMR must be determined for its operation and next, the WMR itself must be located in its position relative to working path. In this paper, the controller is derived based on measuring the tracking errors. Hence, measurability of tracking error components is very important. Some methods for measuring these errors depend on the type of sensor to be used. When some restricted measurability of error occurs, an observer is used as in the work of Leferber (2001). To attain the controllers of Eq. (10) or Eqs. (14-15), errors  $e_1, e_2, e_3$  must be measured. We propose a simple measurement scheme using potentiometers to obtain these values as shown in Fig. 3. Two rollers are placed at points  $O_1$  and  $O_2$ . The distance between the two rollers  $O_1, O_2$ , is chosen according to the curve radius of the reference welding path at contact point  $R(x_r, y_r)$  such as  $\bar{v}_r // \overline{O_1 O_2}$ . The roller diameters are chosen to be small enough to overcome the friction force. From Fig. 3, we have the relationships

$$\begin{cases} e_1 = -r_s \sin e_3, \\ e_2 = (l_s - l) - r_s (1 - \cos e_3), \\ e_3 = \angle(O_1 C, O_1 O_2) - \pi/2, \end{cases} \quad (16)$$

where  $r_s$  is the radius of the roller, and  $l_s$  is the length of the sensor. Hence, we need two sensors for measuring the errors, that is, one linear sensor for

measuring  $(l_s - l)$  and one rotating sensor for measuring the angle between the X coordinate of the WMR and  $\bar{v}_r$ . If the path is a straight line, no measuring error, except measurement noise, occurs. If the path is a curved line, a measuring error occurs when we use the above method to measure the tracking error. This error depends on the radius of the roller,  $r_s$ , the length of the sensor,  $l_s$ , and the length of  $O_1 O_2$ . However, the effect of this error on the overall performance is acceptable as shown in simulation results in the next section.

## 5. SIMULATION RESULTS AND DISCUSSION

To verify the effectiveness of the proposed modeling and controller, simulations have been done for a WMR with a defined reference-welding path. The numerical values used in this simulation are given in Table 1. The welding speed is 7.5 mm/s. The positive constants in the controller are chosen as

$k_1 = 4.2, k_2 = 5000, k_3 = 1$  for the fixed torch case and  $k_1 = 1.2, k_2 = 0.8, k_3 = 0.34$  for the controlled torch length case. The reference path is chosen as shown in Fig. 4.

The first simulation was conducted with a fixed torch WMR with the controller of Eq. (10). Simulation results are given in Figs. 5-8. As shown in Fig. 5 the errors converge to zero after about 12 seconds.

If sensor error is considered, tracking errors occurs, as shown in Fig. 6, when the WMR passes through the curved line. These errors can be overcome with the controlled torch WMR. The welding velocity and the WMR velocities are shown in Fig. 7. The welding velocity still tracks the reference without oscillation. The control inputs are shown in Fig. 8.

The second simulation was done for a WMR with a controllable torch and considering measurement error. The controller in Eqs. (14) and (15) is used. Simulation results are given in Figs. 9-17. For tracking a

Table 1. The numerical values and initial values for simulation.

| Parameters | Values | Units |
|------------|--------|-------|
| $b$        | 0.105  | m     |
| $x_r$      | 0.280  | m     |
| $x_w$      | 0.270  | m     |
| $v$        | 0      | mm/s  |
| $\phi_r$   | 0      | deg   |
| $l$        | 0.15   | m     |
| $r$        | 0.025  | m     |
| $y_r$      | 0.400  | m     |
| $y_w$      | 0.390  | m     |
| $\omega$   | 0      | rad/s |
| $\phi$     | 15     | deg   |
| $\phi_r$   | 0      | rad/s |

straight line, the convergence of the errors is very fast as shown in Fig. 10. With this simulation value, the errors go to nearly zero after 1.5 seconds, faster than in the first simulation. The velocities of the WMR and reference and welding points are given in Fig. 11. The control in-puts are given in Fig. 12. The torch must be controlled according to Eq. (15) and the results are shown in Figs. 13 and 14.

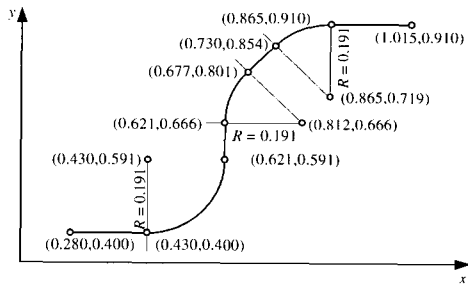

Fig. 4. Reference welding path.

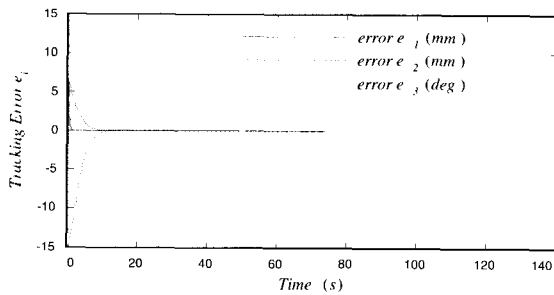

Fig. 5. The tracking errors without measurement error.

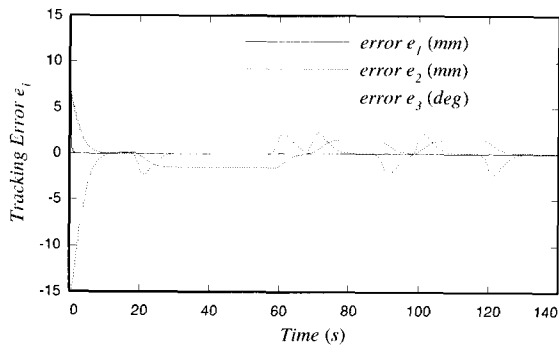

Fig. 6. The tracking errors with measurement error.

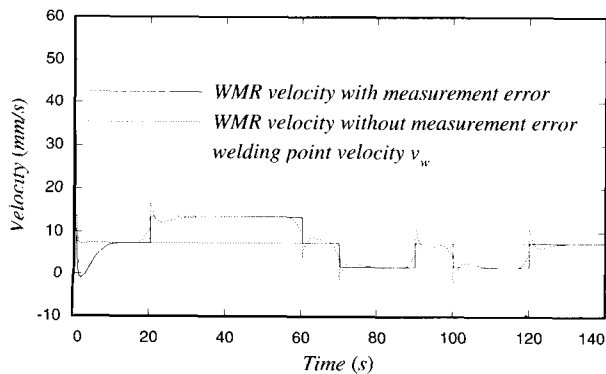

Fig. 7. The velocities of the welding point and the WMR.

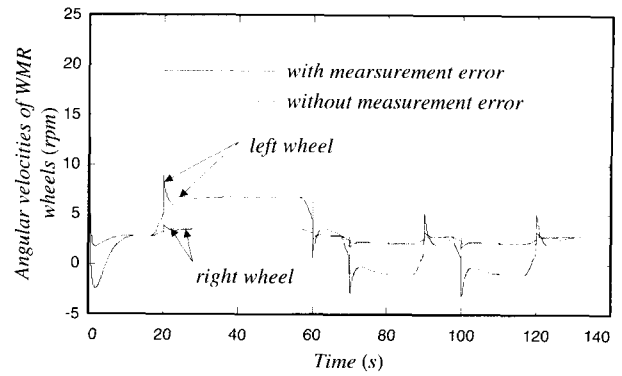

Fig. 8. Control input: angular velocities of the WMR wheels.

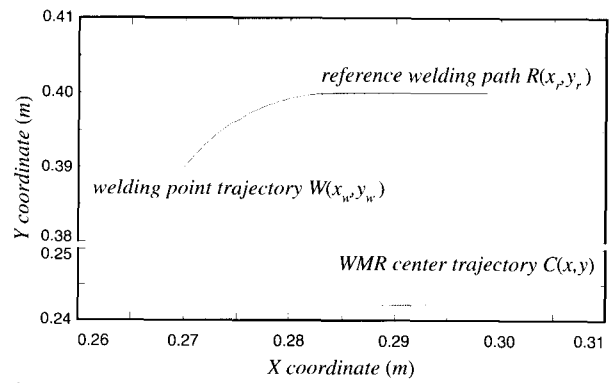

Fig. 9. Trajectories of the WMR and its reference.

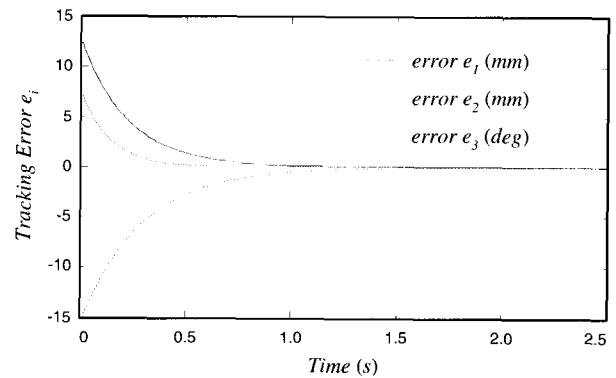

Fig. 10. The tracking errors.

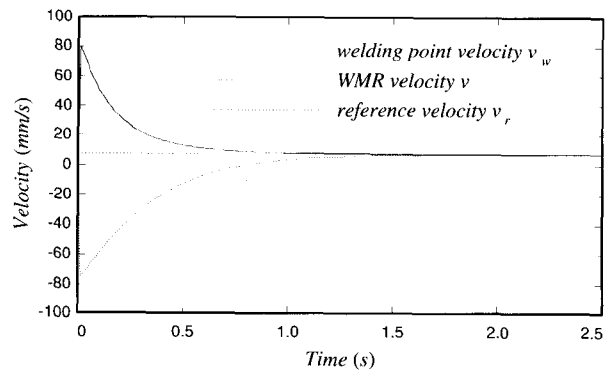

Fig. 11. The velocities of the welding point and the WMR.

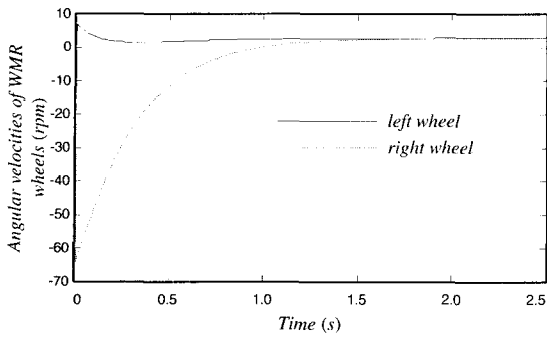

Fig. 12. Control input: angular velocities of the WMR wheels.

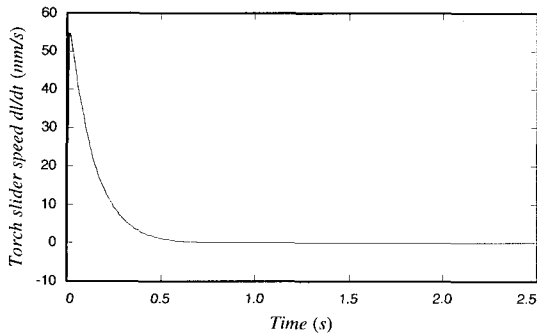

Fig. 13. The torch slider speed  $dl/dt$ .

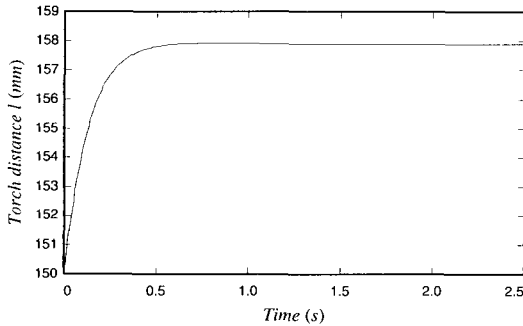

Fig. 14. The torch length  $l$ .

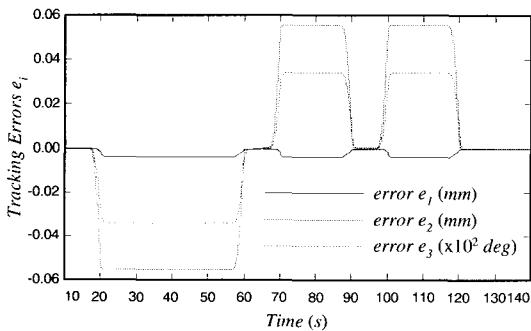

Fig. 15. The tracking errors.

Figs. 15-18 show the differences when the WMR passes through the curved line with and without measurement errors. As shown in Fig. 15, although measurement error is present, the tracking errors have small oscillation. This is acceptable for the WMR application. The welding velocity is unaffected as shown in Fig. 16. The torch slider length is changed as shown in Figs. 17 and 18.

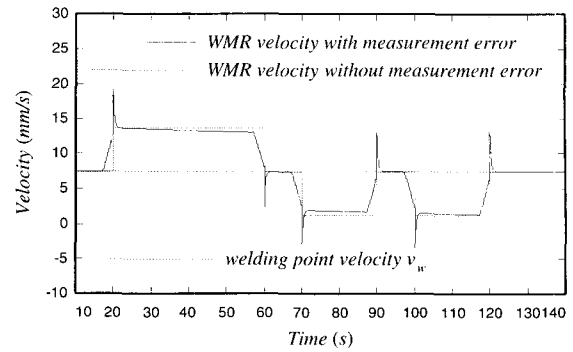

Fig. 16. The velocities of the welding point and the WMR.

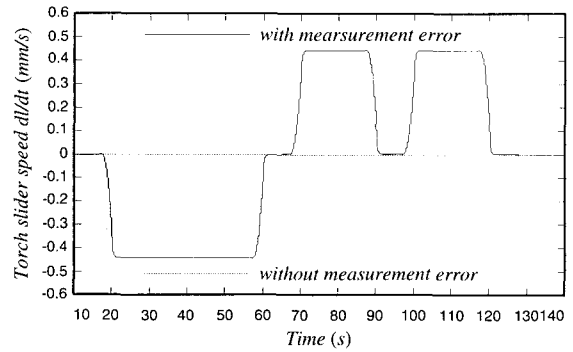

Fig. 17. The torch slider speed  $dl/dt$ .

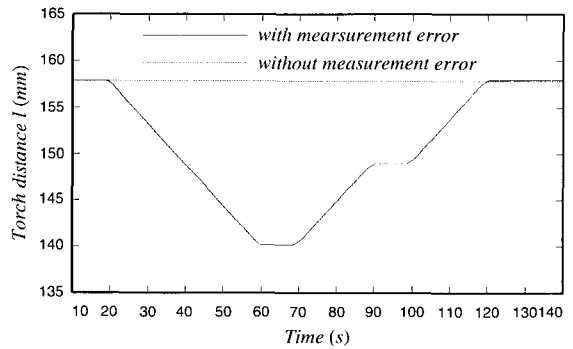

Fig. 18. The torch distance  $l$ .

From the simulation results, we come to the following conclusions. First, a fixed torch WMR can track a straight line, but more time is required for the errors to converge to zero as desired. In addition, when measurement error is considered, large errors occur when the WMR with a fixed torch tracks a curved line, so it is impossible for a WMR with a fixed torch to track any smooth curved line. Secondly, a WMR with a controllable torch can track its reference path faster than a WMR with a fixed torch and can be used for tracking any smooth curved line with acceptable small errors. Thirdly, the proposed simple method for measuring tracking error can be used for two-wheeled WMR.

## 6. CONCLUSIONS

A simple nonlinear controller based on the Lyapunov

control function has been introduced to enhance the WMR's tracking performances. To design the tracking performance, an error configuration is defined and the controller is designed to drive the error to zero as fast as desired. The controlled system attains Lyapunov stability and the controller is flexible with three adjustable parameters. In addition, a simple method is proposed for measuring the errors and deriving the control law. The simulation results show that the controller can be used for the WMR control with good performance.

### REFERENCES

- [1] R. Fierro and F. L. Lewis, "Control of a non-holonomic mobile robot: backstepping kinematics into dynamics," *Proc. of the 34th IEEE Conf. on Decision & Control*, vol. 4, pp. 3805-3810, 1995.
- [2] T. Fukao, H. Nakagawa, and N. Adachi, "Adaptive track-ing control of a nonholonomic mobile robot", *IEEE Trans. on Robotics and Automation*, vol. 16, no. 5, pp. 609-615, 2000.
- [3] Y. B. Jeon, S. S. Park, and S. B. Kim, "Modeling and motion control of mobile robot for lattice type of welding line", *Trans. of KSME International Journal*, vol. 16, no. 1, pp. 1207-1216, 2001.
- [4] Y. B. Jeon, B. O. Kam, S. S. Park, and S. B. Kim, "Seam tracking and welding speed control of mobile robot for lattice type of welding," *Proc. of the 6th IEEE Intl. Symposium on Industrial Electronics*, vol. 2, pp. 857-862, 2001.
- [5] Y. Kanayama, Y. Kimura, F. Miyazaki, and T. Noguchi, "A stable tracking control method for a non-holonomic mobile robot," *Proc. of the 1991 IEEE/RSJ Int. Workshop on Intelligent Robots and Systems*, vol. 3, pp. 1236-1241, 1991.
- [6] B. O. Kam, Y. B. Jeon, and S. B. Kim, "Motion control of two-wheeled welding mobile robot with seam tracking sensor," *Proc. of the 6th IEEE Int. Symposium on Industrial Electronics*, vol. 2, pp. 851-856, 2001.
- [7] M. Y. Kim, K. W. Ko, H. S. Cho, and J. H. Kim, "Visual sensing and recognition of welding environment for intelligent shipyard welding robots," *Proc. of the 2000 IEEE/RSJ Intl. Conf. on Intelligent Robots and Systems*, vol. 3, pp. 2159-2165, 2000.
- [8] E. Lefeber, J. Jakubiak, K. Tchou, and H. Nijmeijer, "Observer based kinematic tracking controller for a unicycle-type mobile robot," *Proc. of the 2001 IEEE Intl. Conf. on Robotics and Automation*, vol. 2, pp. 2084-2089, 2001.
- [9] T. C. Lee, K. T. Song, C. H. Lee, and C. C. Teng, "Tracking control of unicycle-modeled mobile robots using a saturation feedback controller," *IEEE Trans. on Control Systems Technology*, vol. 9, no. 2, pp. 305-318, 2001.
- [10] R. Mukherjee, D. Chen, and G. Song, "Asymptotic feedback stabilization of a non-holonomic mobile robot using a nonlinear oscillator," *Proc. of the 35th IEEE Conf. on Decision and Control*, vol. 2, pp. 1422-1427, 1996.
- [11] P. G. D. Santos, M. A. Armada, and M. A. Jimenez, "Ship building with ROWER," *IEEE Robotics and Automation Magazine*, vol. 7, no. 4, pp. 35-43, 2000.
- [12] N. Sarkar, X. Yun, and V. Kumar, "Control of mechanical systems with rolling constraints: application to dynamic control of mobile robots," *The Intl. Journal of Robotics Research*, vol. 13, no. 1, pp. 55-69, 1994.
- [13] A. Tayebi and A. Rachid, "Backstepping-based discontinuous adaptive control design for the stabilization of non-holonomic mobile robots with matched uncertainties," *Proc. of the 36th IEEE Conf. on Decision and Control*, pp. 1298-1301, 1997.
- [14] K. Tsuchia, T. Urakubo, and K. Tsujita, "A motion control of a two-wheeled mobile robot," *Proc. of the 1999 IEEE Intl. Conf. on Systems, Man, and Cybernetics*, vol. 5, pp. 690-696, 1999.
- [15] X. Yun and N. Sarkar, "Dynamics feedback control of vehicles with two steerable wheels," *Proc. of the 1996 IEEE Intl. Conf. on Robotics and Automation*, vol. 4, pp. 3105-3110, 1996.
- [16] Y. Zheng and P. Moore, "The design of time-optimal control for two-wheeled driven carts tracking a moving target," *Proc. of the 34th IEEE Conf. on Decision and Control*, vol. 4, pp. 3831-3836, 1995.



**Trong Hieu Bui** received the B.S. degree in Mechanical Engineering from Hochiminh City University of Technology, Vietnam, in 1998. He received the M.S. degree in Mechanical Engineering from Pukyong National University, Pusan, Korea, in February 2002. He is currently a Ph.D. student in the Dept. of Mechanical Engineering,

Pukyong National University, Pusan, Korea. His research interests are robust control, nonlinear control, and mobile robot control.



**Tan Tien Nguyen** received the B.S. degree in Mechanical Engineering from Hochiminh City University of Technology, Vietnam, in 1990 and the M.S. degree and Ph.D degree in Mechanical Engineering, Pukyong National University, Pusan, Korea, in August, 1998, and August, 2001, respectively. He is a lecturer of the Dept. of Mechanical

Engineering, Hochiminh City University of Technology, Vietnam. His interests are robust control, nonlinear control and welding automation process control.

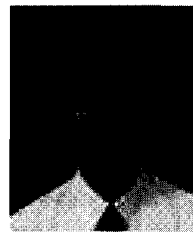

**Tan Lam Chung** received the B.S. degree in Mechanical Engineering, Hochiminh City University of Technology, Vietnam, in 1996 and the B.S. degree in Computer Science from Open University of Hochiminh City, Vietnam, in 1997. He is currently working toward an M.S. degree in Mechanical Engineering from Pukyong National University, Pusan, Korea. His interests are

factory automation, robust control.



**Sang Bong Kim** received the B.S. and M.S. degrees from National Fisheries University of Pusan, Korea in 1978 and 1980, respectively. He received the Ph.D. degree from Tokyo Institute of Technology, Japan, in 1988. He is now a professor of the Dept. of Mechanical Engineering, Pukyong National University, Pusan, Korea. His research has

been on robust control, biomechanical control, and mobile robot control.