

1. 가 .

(International Space Station; , Radar Altimeter, ISS) NASA RASA 가 , DAB, ESA 11 가 (OSTC, , CNES, DLR, ISS ASI, NIVR, NSC, INTA, SNSB , BNSC), , ISS NASDA, CSA, AEB 16 (EXPRESS Pallet, JEM-EF, Columbus-EPF)

2006

ISS NASA ISS 21 (Interface)

2.

ISS 1998 11 20 (Proton) (Zaraya) 2006 ISS 10) ISS (“ (Payload Support & Interface Module; PSIM)” ISS 가 , , , , ISS ISS 가 ISS 가 ISS 가 ISS 500kg . ISS 450 ISS (NASA EXPRESS , 108.5m × 88.4m × 43.6m, 1,200 Pallet JEM-EF) m³ , 350km 450km 90 . ISS NASA가 1 1 . ISS ISS 51.6° 52. 150 , 85% (95%) 가 100 250 가 3

1. ISS

	108.5m x 88.4m x 43.6m
	420 450
	110 kW ()
	1,200 m ³
	1
	350 470 km
	51.6 °
	8 km/ sec
	7 (2002 3)
	10
	\$350 370 ()
가	<ul style="list-style-type: none"> - Starboard Truss () ; 4 · EXPRESS Pallet; 3 (Pallet 6) - JEM-EF () ; 10 - Columbus Module () ; 4

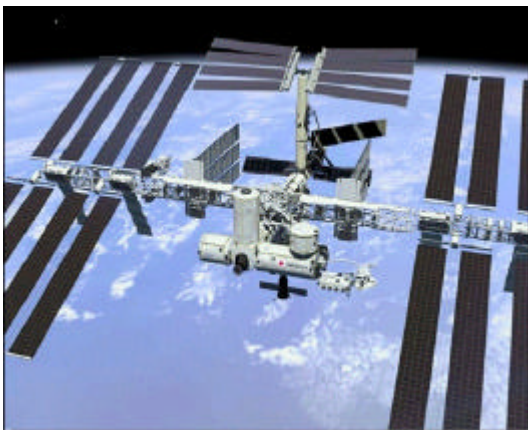

1. ISS (NASA)

ISS ,

()

Starboard (Site) 4 (EXPRESS Pallet
3), Columbus Module
4 , JEM-EF 10
ISS (1)

가 (2)ISS 가 (3)

가 (4) 가

가 (5)
가 가

3.

3.1 U. S. Truss

(Full Attach Site EXPRESS Pallet)

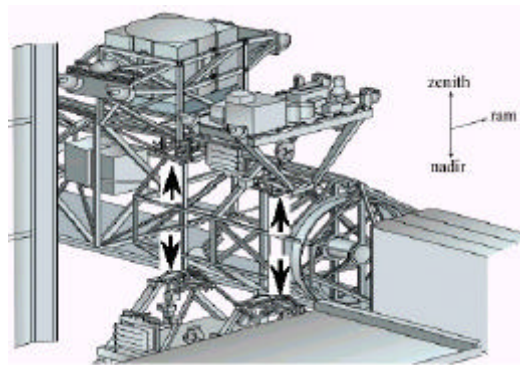

2. U.S. Truss (NASA)

(Full Attach Site EXPRESS Pallet)

(Truss Site,
2) 가 ISS
Full Attach Site
Pallet ISS

EXPRESS Pallet Full Attach Site Starboard Site (Zenith) 1

Center of Gravity (CG) 6,360kg 가 2.23m (Truss) × 4.3m (Ram/ Wake) (Shuttle)

3kW

T&C (Telemetry & Command) MIL-STD-1553B bus 20Kbps , Science 1 2Mbps 가

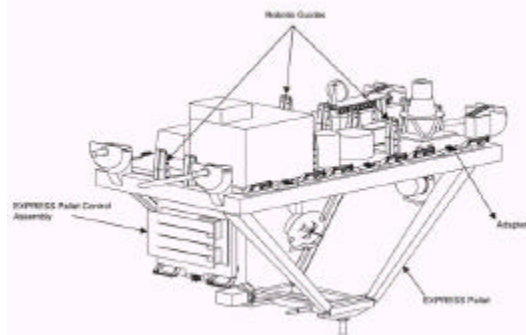

3. EXPRESS Pallet (NASA)

2. EXPRESS Pallet

	- Adapter 227kg
	- 1.1m (Ram/ Wake) × 0.86m (Inboard/ Outboard) × 1.2m (Zenith/ Nadir)
	- 120Vdc 750W, 28Vdc 500W - 120 Vdc 28Vdc 2.5 kW 가 120Vdc
	- Telemetry; 20Kbps - Science ; 6 Mbps
	- GPS 0.1 ° - 2.5 ° - Pointer
	- Pallet -

ISS Full Attach Site ESA Alpha Magnetic Spectrometer (AMS)가 2004 , PSIM 2007 Advanced Cosmic-ray Composition Experiment for the Space Station (ACCESS) NASA EXPRESS Pallet (3) Starboard Truss (Nadir,) 2 Pallet (Zenith) 1 Pallet EXPRESS Pallet Pallet 6 Adapter Plates가 18 가 NASA Agency (CSA) Canadian Space

PSIM

3.2 JEM-EF

Japanese Experiment Module-Exposed Facility (JEM-EF) 10 가

5
NASA가 , 5
NASA가 가

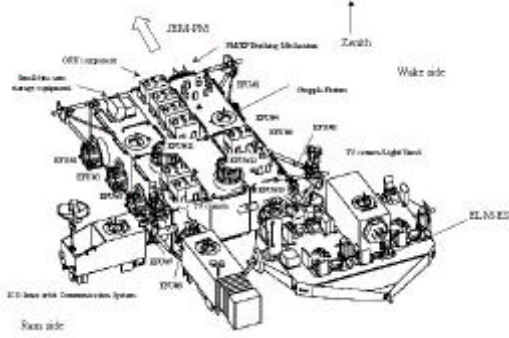

4. JEMEF (NASA)

3. JEMEF

	- 8 ; 500kg - 2 ; 2,500kg
	- 1.85m (ram/ wake) × 0.8m (inboard/ outboard) × 1.0m (zenith/ nadir)
	- 120Vdc 3 kW - 10 10 kW
	- Telemetry; 1Mbps - ; FDDI 100Mbps
	- Active thermal cooling 가
	- JEM Airlock ()

4 JEM-EF
JEM-PM (Pressurized Module)

(Field of View; FOV) 8 가 2

()
Ram (ISS)

Wake 4
Ram , 4 Wake
, 2 Ram Wake

3 JEM-EF
NASA

JEM-EF / 가
EXPRESS Pallet NASA
가

3.3 Columbus- EPF

(ESA; European Space Agency)
/ Columbus Exposed
Payload Facility (Columbus-EPF) 4

가 . 2
NASA , 2
ESA 가 .
가

가
. 2 / ram/ wake
가 , 2
/ ram/ wake
5 Columbus
EPF , 4 Columbus-EPF

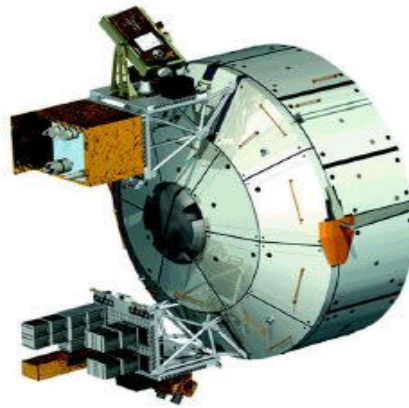

5. Columbus-EPF (ESA)

4. Columbus-EPF

	- 227kg
	- 1.1m (Ram/ Wake) × 0.86m(Inboard/ Outboard) × 1.2m (Zenith/ Nadir)
	- 4 2.5 kW
	- Telemetry; 10 Kbps ; TBD
	-

ISS

ISS

가 RASA 가 ESA

1. Betsy Park, Attached Payload and Optical Window Accommodation for the ISS, USRA 32nd Meeting, 2001
2. NASA & ESA, ISS User's Guide, NASA & ESA Document, 2001, pp.11-13
3. NASA, HSF-International Space Station <http://spaceflight.nasa.gov/station>, ISS, 2001

4.

NASA
 EXPRESS Pallet, NASDA JEM-EF,
 (ESA) Columbus-EPF
 가
 가
 EXPRESS Pallet JEM-EF
 NASA
 Goddard Space Flight Center “
 (PSIM) ”
 , ISS
 ISS
 NASA
 , NASDA
 가 ISS
 가
 ISS
 가
 ISS
 가 ISS