

Fatigue of Grout Type Transverse Joint

Yoon-Chil Kim ¹⁾ and Jong-Jin Park ^{2)*}

¹⁾ Dept. of Architectural Engineering, Kyongju University, Korea

²⁾ Research and Development Center, Korea Railroad Technical Corporation, Korea

(Received July 21, 2001; Accepted May 30, 2002)

Abstract

This is the second of two part series on experimental studies of grout type transverse joints. In this paper, grout-type transverse joints between precast concrete slabs are tested to study the fatigue behavior. The tests are performed with loading equipment designed and constructed especially in the lab to introduce shear fatigue failures on the joints of the test specimens with repeated loads. Non-prestressed as well as prestressed specimens are selected based on static tests and these specimens are studied to identify the effect of prestress on the fatigue strength of the grout type joint. A comparison between prestressed and non-prestressed specimens indicates that longitudinal prestressing is an effective method to increase fatigue strength of the transverse joints. Based on the fatigue test, a rational estimation of the fatigue strength is proposed to aid design of the grout-type transverse joints.

Keywords: grout type transverse joints, precast concrete slabs, prestress and fatigue strength

1. Introduction

Precast concrete slabs are pre-fabricated transverse floors that are gaining a wide popularity for the construction of bridge structures. Use of the precast slabs ensures the quality and reduces amount of shrinkage, which in turn enhances the durability of the slabs.¹⁾ With the introduction of prestress to the precast concrete slabs, development of cracks on the slabs due to traffic loads can also be controlled. Use of the precast concrete slabs is an economical alternative that can reduce the cost of maintenance compared to conventional reinforced concrete slabs.²⁾

There are disadvantages in the precast concrete slab. Due to the limitation of transportation, size of the precast slabs has to be small enough to accommodate transportation. Structurally weak transverse joints are also necessary in order to provide continuity of the precast slabs. Even though research and design of the precast concrete slabs are actively conducted,³⁻⁵⁾ detailed design specifications of the transverse joints are not yet available. Use of rebar and mechanical connection makes structural details of the precast slab very complicated and raise construction cost at the

same time.^{6,7)}

In this paper, the simplest form of the transverse joint, grouted joint, was studied to determine its fatigue behavior under a repeated shear force. This study follows a static test conducted on the same type of the transverse joint.⁸⁾ The fatigue behavior was tested with test specimens selected based on the static test performed with shear loading equipment developed in the laboratory. The loading equipment for the fatigue test is basically the same as that of the static test except that the end support condition is improved in order to restrict rotation completely.⁸⁾ In order to simplify the study, only the amount of prestress introduced to the test specimens was selected as sole test parameter to study the effect of prestress on fatigue strength of the grout type transverse joint. Based on the test results, estimation of fatigue strength for the grout type joints are presented.

2. Test equipment and specimen

As shown in Fig. 1 and Table 1, beam specimens were selected as simplified representations of the precast slabs with transverse joint.^{9,10)} Depth of the beam specimens was 250 mm, similar dimension to usual slab thickness. Several shapes of the grout type joints were subjected to the static test, and the C type specimen was chosen based on per-

* Corresponding author

Tel.: +82-2-2186-1974; Fax.: +82-2-2186-1869

E-mail address: cougars@krtc.co.kr

Table 1 Test specimens

Type of test specimens	Amount of prestress (MPa)	Applied load (KN)	Model names	Grout material	Material properties
C type	0	29.5	C-0-29.5	Non-shrinkage mortar	Compressional strength 393 kgf/cm ² Youngs modulus 2.83 x 10 ⁵ kgf/cm ²
		41.3	C-0-41.3		
		64.9	C-0-64.9		
		88.5	C-0-88.5		
	0.49	41.3	C-0.49-41.3		
		64.9	C-0.49-64.9		
		88.5	C-0.49-88.5		
	1.96	64.9	C-1.96-64.9		
88.5		C-1.96-88.5			

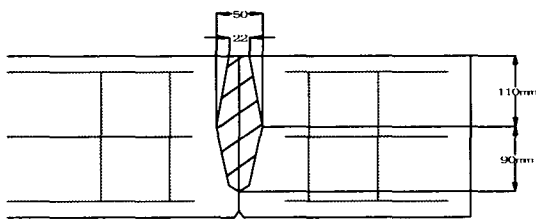

(a) C type specimen

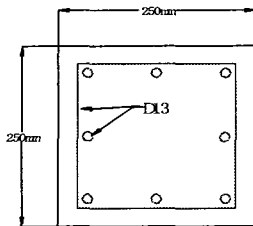

(b) Cross section

Fig. 1 Test specimens

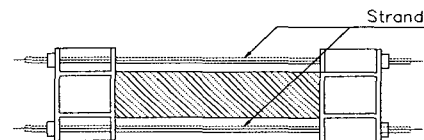
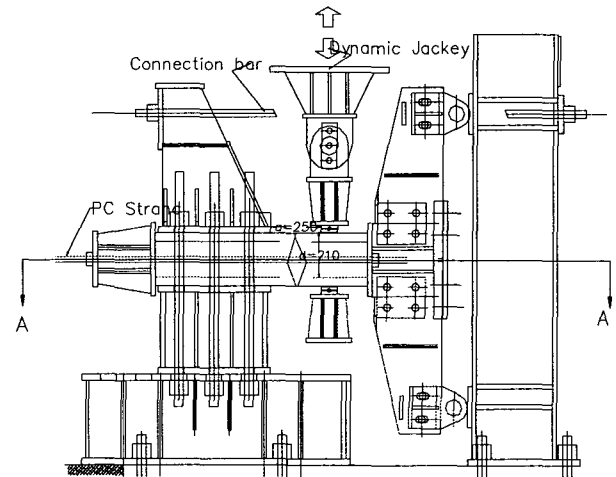

Fig. 2 Loading apparatus

formance of the static loading test.⁸⁾ Dimensions of joint and cross section of the C type specimens are shown in Fig. 1. Non-shrinkage mortar was used as grouting materials for the C type specimens. The C type specimens were tested with different amount of prestress (0 to 1.96 Mpa) introduced to the specimens. Amount of prestress to each specimen is shown in Table 1. Prestress was introduced to the specimens by the external prestressing method with two tendons on which strain gages were attached to control tension.^{11,12)} The specimens were loaded on the shear test apparatus as shown in Fig. 2. The apparatus provides a fixed support at one end while rotation is constrained at the other end. Rotational constraint at the free end is improved compared to the static test equipment in order to eliminate small and undetectable amount of rotation introduced at the free end. As shown in Fig. 3, pure shear force on the transverse joints is applied by placing the joint where bending moment becomes zero. Shear force on the transverse joints is ap-

plied because fatigue failure of the concrete slab is commonly induced by shear force.¹³⁾

3. Determination of applied loads

Large traffic loads concentrated on relatively small loading areas are applied on concrete slab of the bridge structures. This phenomenon causes a particular type of failure on slabs, punching shear failure.^{1,13)} Transverse joints between precast slabs are also vulnerable to a fatigue failure that, it is necessary to test for the durability with a repeated load applied on the test specimens. From the results of the previous static loading tests, the C type specimen was selected and its fatigue performance was tested. Only the amount of prestress was varied as a test parameter. Combi-

Table 2 Bearing capacities of test specimens

Model	Prestress (Mpa)	Cracking load (KN)	Ultimate load (KN)
C-0	0	117	137
C-0.49	0.49	129	171
C-1.96	1.96	173	245

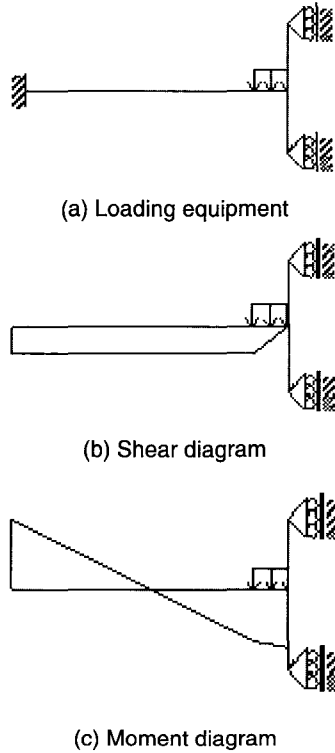

Fig. 3 Shear and moment distribution

nations of applied load and amount of prestress introduced on the specimens are shown in Table 1. The specimens are referred in the order of type-amount of prestress-applied load. For example, C-0.49-29.5 means that the C type specimen with 0.49 MPa of prestress is subjected to 29.5 KN of repeated load. Displacement at the loading position was measured as the fatigue load acted on the specimens at 2.5 Hz.

The actual applied loads were determined based on the static load test for the C-0 specimen (non-prestressed specimen). As shown in Table 2, the cracking load for the non-prestressed C type specimen (C-0) was 117 KN. The applied loads for the fatigue tests were set to be 25 % (29.5 KN), 35 % (41.3 KN), 55 % (64.9 KN) and 75 % (88.5 KN) of the cracking load for the non-prestressed C-0 specimen. It should be noticed that the cracking load for the C-0 specimen indicated in Table 2 is higher than what is indicated in the previous static test.⁸⁾ This is due to the improvement of the support condition to restrict rotation.

In order to compare the applied load with actual shear

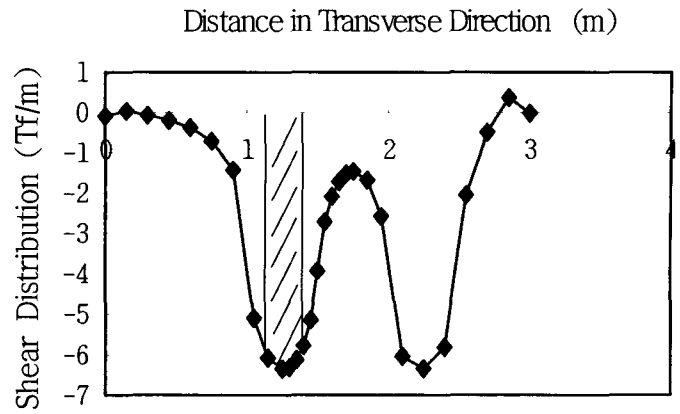

Fig. 4 Shear force per unit length of concrete slab

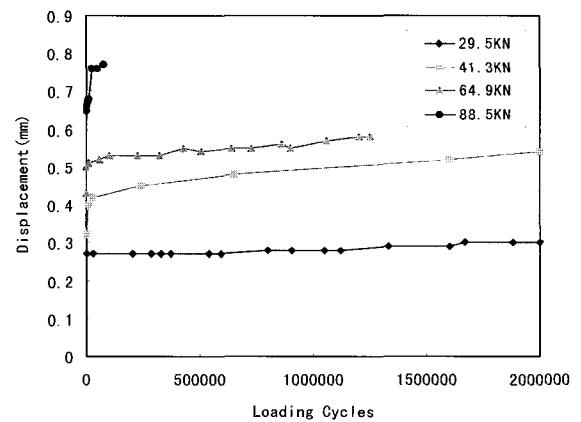

Fig. 5 Loading cycles vs. displacement (C-0 specimens)

force of a bridge deck caused by a traffic load, FEM analysis of a simply supported bridge structure with 30 m in span length and 3 m width was performed with an applied load of 147 KN, which was the maximum of measured vehicular load from a field test. From the results of the analysis, the maximum equivalent shear force that acted on 250 mm of the concrete slab was determined by integrating the shaded area in Fig. 4. The maximum equivalent shear force on 250 mm width was 15.1 KN. The applied loads for the tests were set to be at least twice as much as the shear force to which actual bridge deck is subjected.

4. Test result

4.1 Behavior of C-0 specimens

Fig. 5 shows the displacements for the C type specimens during the fatigue test. Except for the C-0-88.5 specimen, large variations of displacement are not found throughout the course of the test. When the applied load was 29.5 KN (25 %), failure of the transverse joint did not occur until the

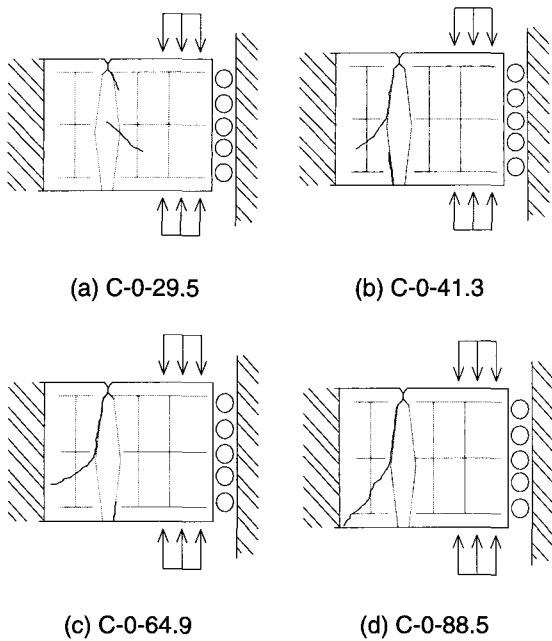

Fig. 6 Failure patterns of C type specimens

Table 3 Fatigue loading cycles

Load (KN)	C-0	C-0.49	C-1.96
41.3	1,500,000	2,000,000	-
64.9	700,000	1,300,000	2,000,000
88.5	77,400	220,000	520,000

completion of test when two million repetitions had been performed. Only the crack in length of 5 cm was formed along the interface and near the neutral axis after one million repetitions. However, further development of crack was not observed until two million repetitions were completed. The crack pattern for the C-0-29.5 specimens is shown in Fig. 6(a).

When 41.3 KN (35 %) was applied on the C-0 specimen, a gradual increase of displacement was observed. As seen in Fig. 6(b), inclined shear crack also appeared at 1.3 million repetitions. A gradual development of the crack length contributed to slow increase of displacement throughout the course of test. A failure was not observed after two million repetitions even though excessive displacement was observed.

For the C-0-64.9 specimen, a vertical crack was detected at the interface of the transverse joint when the load reached 500,000 repetitions. This interfacial crack grew downward to the neutral axis until 700,000 repetitions, at which time limit displacement was reached. Inclined shear crack, as seen in Fig. 6(c) began to develop below the neutral axis with gradual increase of displacement. The test was terminated at 1.5 million repetitions due to a severe

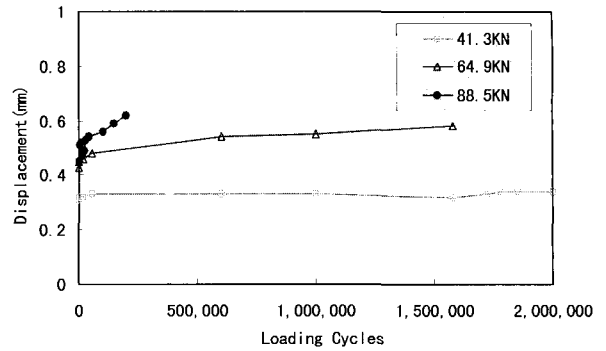

Fig. 7 Loading cycles vs. displacement (C-0.49 specimens)

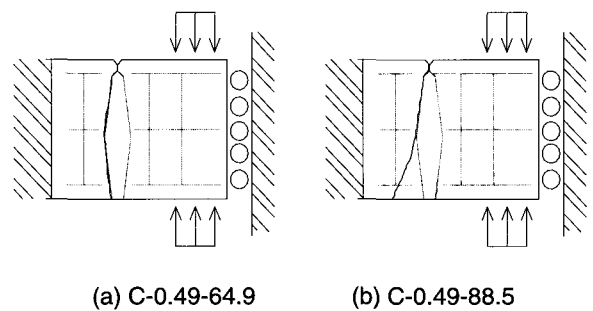

Fig. 8 Failure patterns of C-0.49 specimens

displacement. The crack pattern of the C-0-88.5 specimen was the same as that of the C-0-64.9 specimen, except that the vertical interfacial crack appeared much earlier at 5,000 repetitions. Soon after, the interfacial crack joined with inclined shear crack developed near the neutral axis of the specimen. Fatigue failure with propagation of the crack through the full depth of the specimen was observed. The test was terminated at 77,400 repetitions because of an excessive displacement.

4.2 Behavior of C-0.49 specimens

C-0.49-88.5 specimen was tested first. The displacement during the fatigue test for C-0.49 specimens is shown in Fig. 7. Initial crack appeared at 5,000 repetitions and propagated along the interface as the test progressed. Failure of the C-0.49-88.5 specimen occurred with a development of interfacial crack through the full depth of the specimen at completion of approximately 200,000 repetitions. The failure pattern is given in Fig. 8.

Applied loading was reduced to 64.9 KN for the following test. At 600,000 repetitions, a full depth crack was formed. However, a sudden increase of displacement was not induced due to the compression of prestress on the cracked surface. Only the displacement was steadily increased until 1.5 million repetitions, at which time an ex-

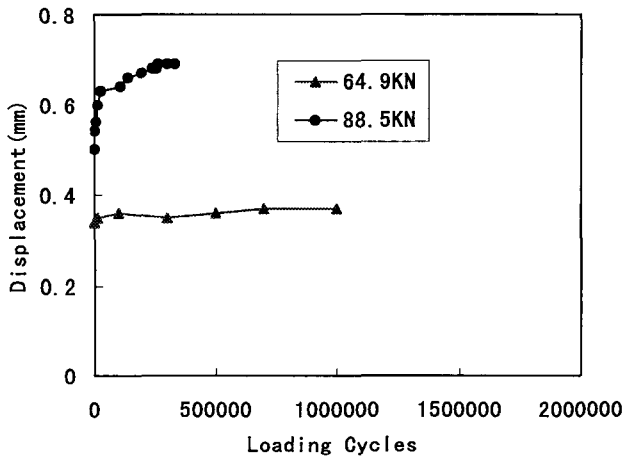

Fig. 9 Loading cycles vs. displacement (C-1.96 specimens)

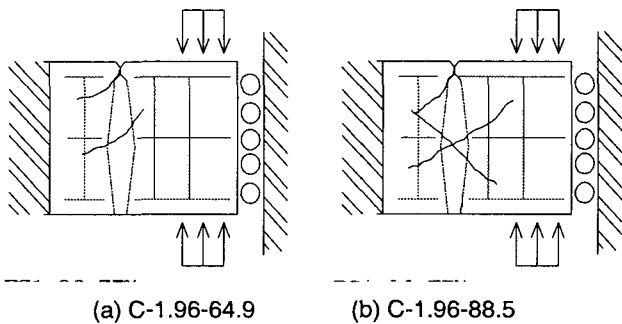

Fig. 10 Failure patterns of C-1.96 specimens

cessive displacement was observed. Failure of the C-0.49-41.3 specimen was not observed until 2 million repetitions and a further test with 29.5 KN was not carried out.

4.3 Behavior of C-1.96 specimens

The effect of prestress is clearly demonstrated for the C-1.96 specimens. As illustrated in Fig. 9, displacement of the specimens remained small except for C-1.96-88.5 specimen. Tensile cracks along the interfaces of the joints were limited only on the top portion of the specimens because of 1.96 Mpa of prestress introduced to the specimens. The main cause of the failures was inclined shear crack which appeared at the web of the transverse joint. One million repetitions of loadings had been carried out before terminating the test due to an excess of displacement for the C-1.96-88.5 specimen. The failure patterns for C-1.96 specimens are shown in Fig. 10. Two diagonal shear cracks, which crossed each other, were developed in the web for the C-1.96-88.5 specimen. For the C-1.96-64.9 specimen, a gradual increase of displacement was observed without any noticeable development of crack. Only a shear crack in limited length was observed at the completion of the test. Fur-

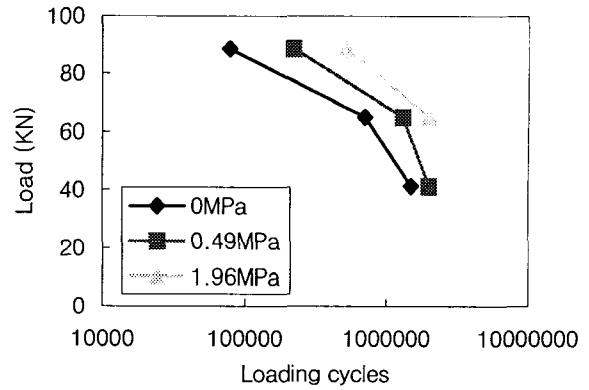

Fig. 11 S-N curves for grout type joint

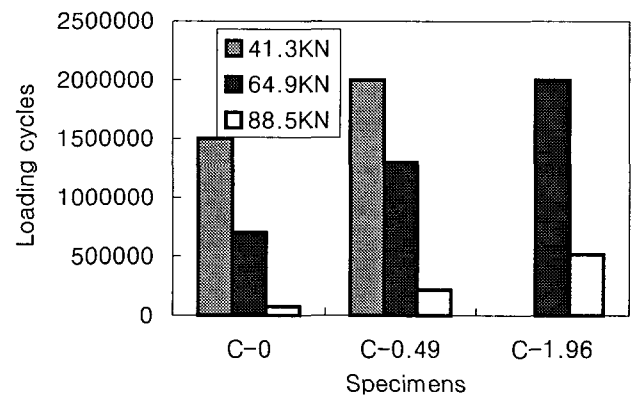

Fig. 12 Fatigue loading cycles to reach limit state

ther test with 41.3 KN of design load is not performed.

4.4 Fatigue strength of transverse joint (S-N curve)

Fatigue strengths of all test type specimens are shown in Fig. 11 based on the test results. Table 3 also shows the fatigue strength of each specimen with regard to 41.3 KN, 64.5 KN, and 88.5 KN of loads. The effect of prestress is clearly indicated, as seen in Fig. 12, by the increase of fatigue life for the prestressed specimens. Prestress amount of 1.96 Mpa increases fatigue life by 280 % and 670 % when the applied loads are 64.9 KN and 88.5 KN, respectively.

The analysis of a bridge deck indicated that shear force applied on the concrete deck 250 mm in width was only about 15 KN, 13 % of the shear cracking load determined by the static test. The test results indicate that at least 2 million repetitions of fatigue load is assured even without prestress under the traffic load 15 KN. Prestress amount of 0.49 Mpa is enough to guarantee 2 million repetitions when the actual traffic load is increased by three folds up to 41.3 KN.

When applied loads are normalized by the ultimate bearing capacities of each specimen,^{14,15} the lines merge to form a single line as seen in Fig. 13. The solid line shown

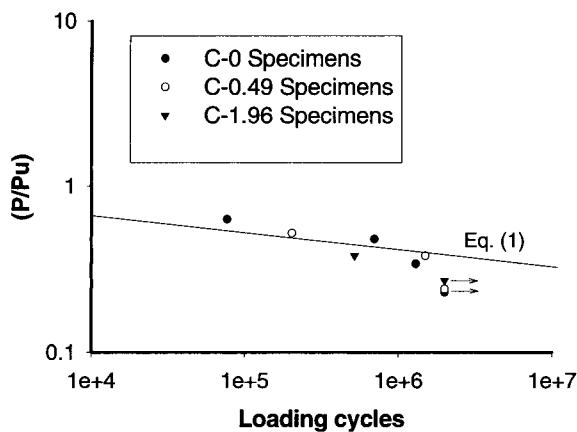

P : applied shear force (KN)
 Pu : ultimate shear capacity (KN)

Fig. 13 Normalized S-N curve for grout type joint

in Fig. 13 is the fatigue strength of concrete slab suggested by Matsui. It is given as;

$$\log (P/P_u) = -0.07835 \log N + \log C \quad (1)$$

where,

P : applied load

Pu : punching shear capacity of the concrete slab.

N : number of loading cycles which can be applied on the slab

C : a constant.

Clear association of the plotted data and Matsui's equation is indicated in Fig. 13 except for the long-life region where loading cycles are 2 million repetitions. It is because the tests were terminated, before failure, at the maximum of 2 million repetitions. The limited amount of test data also makes it difficult to clearly identify the agreement with the equation given by Matsui. However, a fairly close relationship is shown within the short life region, where complete tests were performed until the failures of the test specimens had been observed. A thorough research in long-life region deems to be necessary in order to identify the complete fatigue behavior of the transverse joint.

9. Conclusion

Fatigue strength of the grout type transverse joints is tested with a loading equipment designed and constructed in the lab. The followings are confirmed as results.

- (1) By restraining the free end of the cantilever beam from rotation, fatigue failure due to pure shear can be successfully induced.
- (2) Even without prestress, grout type transverse joint pos-

sesses enough fatigue strength to endure 2 million repetitions of usual traffic load.

- (3) Prestress increases fatigue strength of the grout type transverse joint. Compared to the non-prestressed specimens, 0.49 Mpa of prestress considerably increases the fatigue strength of the grout joint. Two million repetitions are assured under the three times the traffic load.
- (4) A normalized S-N curve of the grout type transverse joint can be obtained by dividing the applied force by the ultimate shear strength of respective specimens.

The labor cost can be reduced if precast slabs are used for the construction of bridge structures. However, design specifications for the transverse joint must be established. Estimations of fatigue strength for the grout type joint can be obtained from the S-N curve and it may accommodate the design of such joints.

REFERENCES

1. Matsui, S., "Technology Development for Bridge Deck Innovations on Durability and Construction," *Journal of Bridge and Foundation Engineering*, Vol. 31, No. 8, 1997, pp.84-94.
2. Nagai, H., "Design of Composite Bridge Structures Using Precast Concrete Slabs," Morikita, Tokyo, Japan.
3. Ota, H., Matsui, S., Higashiyama, H., and Park, J. J., "Behavior of PCa-RC Slab Prestressed by External Cables," *Proceedings, 52th Annual Conference*, Nagoya, JSCE, Vol.52, 1998, pp.362-363.
4. Kim, Y. C., "Study on Mechanical Characteristics and Fatigue Durability of Joint of Precast Decks," Ph.D Thesis, Osaka University, 2001.
5. Taniuchi, H., Ikeda, K., and Sato, N., "Replacing Method of Bridge Slabs under Heavy Traffic Volume and Some Recent Strengthening Methods for Bridge Members," *Proceedings, JSBM 98, Osaka*, Osaka University, Vol.3, 1998, pp.362-363.
6. Park, J. J., Cheung, J. W., and Shin, S. B., "Experimental Study on Strengthening Transverse Joints between Precast Concrete Slabs," *KCI Concrete Journal*, Vol. 12, No. 2, 2000, pp.45-54.
7. Kim, Y., Matsui, S., Egashira, K., and Miyagawa, O., "Experimental Study on the Shear Strength of Shear Key Joints of Precast Slab," *Proceedings of 21th JCI Annual Conference*, 1999, pp.829-834.
8. Kim, Y. C. and Park, J. J., "Shear Strength of Grout Type Transverse Joint," *KCI Concrete Journal*, Vol. 14, No. 1, 2002, pp.8-14.
9. Chung, C. H., Kim, Y. J., Kim, S. W., and Park, C. L., "Static Tests on Transverse Joints of Precast Prestressed Concrete Bridge Deck," *Journal of the Korea Concrete Institute*, Vol. 10, No. 2, 1998, pp.109-117.
10. Kim, Y. J., Chung, C. H., and Shim, C. S., "A Study on Bond Properties of Joint Grouting Materials for Precast Concrete Bridge Decks," *Journal of the Korea Concrete Institute*, Vol. 10, No. 1, 1998, pp.153-160.

11. Li, W., Albrecht, P., and Saadatmanesh, H., "Strengthening of Composite Steel-Concrete Bridges," *Journal of Structural Engineering*, Vol. 121, No. 12, 1995, pp.1842-1849.
12. Park, J. J. and Cheung, J. W., "Prestressing the Precast Concrete Slabs with External Cables," Vol. 4, No. 1, 2000, pp.11-18.
13. Albrecht, P., Li, W., and Saadatmanesh, H., "Fatigue Strength of Prestressed Steel-Concrete Beams," *Journal of Structural Engineering*, Vol. 121, No. 12, 1995, pp.1842-1849.
14. Albrecht, P., Li, W., and Saadatmanesh, H., "Fatigue Strength of Prestressed Steel-Concrete Beams," *Journal of Structural Engineering*, Vol. 121, No. 12, 1995, pp.1842-1849.
15. Matsui, S., "Fatigue Strength of Concrete Slab for Bridge Structures," Ph.D. Thesis, Osaka University, 1984.