

## Expression of the *E. coli LacZ* Gene in Chicken Embryos Using Replication Defective Retroviral Vectors Packaged With Vesicular Stomatitis Virus G Glycoprotein Envelopes

Teoan Kim\*, Young Man Lee, Hoon Taek Lee<sup>1</sup>, Young Tae Heo<sup>1</sup>, Heng-Cherl Yom<sup>2</sup>, Mo Sun Kwon<sup>3</sup>  
Bon Chul Koo<sup>3</sup>, Key Whang<sup>4</sup> and Kwang Soo Roh<sup>3</sup>

Department of Physiology, School of Medicine Catholic University of Taegu-Hyosung, Taegu 705-718, Korea

**ABSTRACT :** Despite the high potency of the retrovirus vector system in gene transfer, one of the main drawbacks of has been difficulty in preparing highly concentrated virus stock. Numerous efforts to boost the virus titer have ended in unsatisfactory results mainly due to fragile property of retrovirus envelope protein. In this study, to overcome this problem, we constructed our own retrovirus vector system producing vector viruses encapsulated with VSV-G (vesicular stomatitis virus G glycoprotein). Concentration process of the virus stock by ultracentrifuge did not sacrifice the virus infectivity, resulting in more than  $10^8$  to  $10^9$  CFU (colony forming unit) per ml on most of the target cell lines tested. Application of this high-titer retrovirus vector system was tested on chicken embryos. Injection of virus stock beneath the blastoderms of pre-incubated fertilized eggs resulted in chick embryos expressing *E. coli LacZ* gene with 100% efficiency. Therefore, our results suggest that it is possible to transfer the foreign gene into chicken embryo using our high-titer retrovirus vector. (*Asian-Aust. J. Anim. Sci.* 2001. Vol. 14, No. 2 : 163-169)

**Key Words :** Retrovirus Vector, Vesicular Stomatitis Virus G Glycoprotein, *E. coli LacZ* Gene, Green Fluorescent Protein, Transgenic Chicken Embryo

### INTRODUCTION

Until recently, most of studies related to the production of transgenic animals have been done mainly on mammals. In spite of immense investment of time and money few reports of transgenic domestic animals exist as yet, indicating a dismal prospective from an economical point of view for producing transgenic livestock.

Considering several farming advantages of avians over mammals, such as shorter generation time and higher productivity, the production of a transgenic chicken might be the best alternative to the inefficient production of transgenic mammalian farm animals. Among several methods established so far for transgenic chicken production, retrovirus-mediated gene transfer is the most efficient approach in terms of technical ease and effectiveness of gene transfer (reviewed by Muramatsu et al., 1998).

One of the main drawbacks of retrovirus vector system, however, has been difficulty in preparing highly concentrated virus stock. Since retrovirus envelope proteins encapsulating progeny virus RNA are unstable, physical concentration procedures such as centrifugation result in only small increases in titer due to loss of infectivity. Several solutions reported so far for the low titer problem include boosting virus production by treating virus-producing cells with sodium butyrate (Olsen and Sechelski, 1995), and concentration of virus stock by either centrifugal filtration (Olsen et al., 1994) or ultracentrifugation (Pear et al., 1993). Most remarkably, Burns et al. (1993) reported a new pseudotyped retrovirus vector system, in which the produced viruses were packaged by vesicular stomatitis virus G glycoprotein (VSV-G). Two main advantages of the VSV-G pseudotyped retrovirus vector system over other counterparts are, first, high and pantropic infectivity of the produced viruses which can infect cells derived from almost all vertebrates, and second, feasibility of ultracentrifugal concentration of virus stock without loss of virus infectivity.

In this study, we have developed our own retrovirus vector system from which the progeny viruses were encapsulated with VSV-G. Preliminary data demonstrated high infectivity to a wide range of host cells and, most importantly, feasibility of concentration without loss of infectivity. Encouraged with these results, we tested the applicability of this gene transfer system to transgenic chicken production.

\* Address reprint request to Teoan Kim. Tel: +82-53-650-44470, Fax: +82-53-621-4106, E-mail: takim@cuth.cataegu.ac.kr.

<sup>1</sup> Animal Resources Research Center, Konkuk University, Seoul, Korea.

<sup>2</sup> Department of Life Sciences, Hoseo University, Asan, Korea.

<sup>3</sup> Department of Biology, Keimyung University, Taegu, Korea.

<sup>4</sup> Department of Food Science and Technology, Keimyung University, Taegu, Korea

Received August 16, 2000; Accepted September 28, 2000

## MATERIALS AND METHODS

### Cell culture

All cell lines, including 293 (human embryonal kidney cell transformed by human adenovirus type 5 DNA, ATCC CRL 1573), PG13 (packaging cell line characterized by expression of Gibbon ape leukemia virus envelope gene, Miller et al., 1991), EBTr (bovine embryonic trachea cell, ATCC CCL 44), HeLa (human cervix carcinoma cell, ATCC CCL 2), and primary culture of CEF (chicken embryonic fibroblast), were grown in Dulbecco's Modified Eagle Medium (DMEM) with 4.5 g/l of glucose (Sigma D7777) supplemented with FCS (10%), penicillin (100  $\mu$ /ml) and streptomycin (100  $\mu$ g/ml). The cells were grown in a 37°C, 5% CO<sub>2</sub> incubator.

### Construction of 293mGPHy cell line expressing *gag* and *pol* genes

293mGPHy cell line was constructed by transfection of 293 cells with the DNA designed to express MoMLV (Moloney murine leukemia virus) *gag* and *pol* genes. Due to difficulty in transfection resulting in successful expressions of the *gag* and *pol* genes, however, a little complicated selection strategy was employed (figure 1). Briefly, 293 cells were co-transfected with pLGPS (Miller et al., 1991) coding for MoMLV *gag* and *pol* genes, and pJZ122SVHy (kindly provided from Dr. Jiaou Zhang) designed to express the *Hyg*<sup>R</sup> (hygromycin B resistant) gene under the control of the SV40 promoter. For co-transfection, calcium phosphate method was employed using commercially available kit (Gibco/BRL) with 20  $\mu$ g of pLGPS and 2  $\mu$ g of pJZ122SVHy per  $1 \times 10^6$  cells plated the previous day in a 100 mm dish. Due to sensitivity of 293 cells to calcium, DNA-calcium precipitate was replaced with fresh culture medium 8 hours after transfection. Following 2 weeks of selection with hygromycin B (100  $\mu$ g/ml), twelve actively proliferating *Hyg*<sup>R</sup> colonies were saved. Among them, the best colony in terms of the *gag* and the *pol* gene expressions was selected based on virus productivity.

### Production of retrovirus vector

Introductions of gene sequences of retrovirus vector and VSV-G were done to convert *Hyg*<sup>R</sup> 293 cells containing the *gag* and *pol* genes to virus-producing cells (figure 1). Firstly, LN $\beta$ Z or LN $\beta$ eGFP retrovirus vector DNA sequence (figure 2) was introduced by infecting the cells with the medium taken from PG13 packaging cells (Miller et al., 1991) stably expressing LN $\beta$ Z or LN $\beta$ eGFP provirus, then the cells were allowed two weeks for G418 (600  $\mu$ g/ml) selection. Secondly, to introduce VSV-G gene which is equivalent to the retrovirus *env* gene, the

cells underwent calcium phosphate transfection by adding 20  $\mu$ g of plasmid pHCMV-G (Yee et al., 1994; obtained from Dr. Jane C. Burns) in 1 ml of calcium phosphate solution to the Neo<sup>R</sup> (G418 resistant) 293mGPHy cells plated on the previous day ( $1 \times 10^6$  cells/100 mm dish). After 8 hours of incubation at 37°C with 5% CO<sub>2</sub> in air, calcium phosphate solution was aspirated to culture the cells with 10 ml of medium. Because VSV-G is cytotoxic, the medium containing retrovirus vectors was harvested after 48 hours of transfection.

To produce virus vectors from the PG13 packaging cells, the cells were infected with the medium taken from PA317 (amphotropic murine leukemia virus-based; Miller and Buttimore, 1986) transiently transfected with LN $\beta$ Z or pLN $\beta$ eGFP. The medium taken from the pools of PG13 cell colonies survived from 2 weeks of G418 selection (800  $\mu$ g/ml) was used to infect target cells to compare the infectivity of the viruses encapsidated with VSV-G.

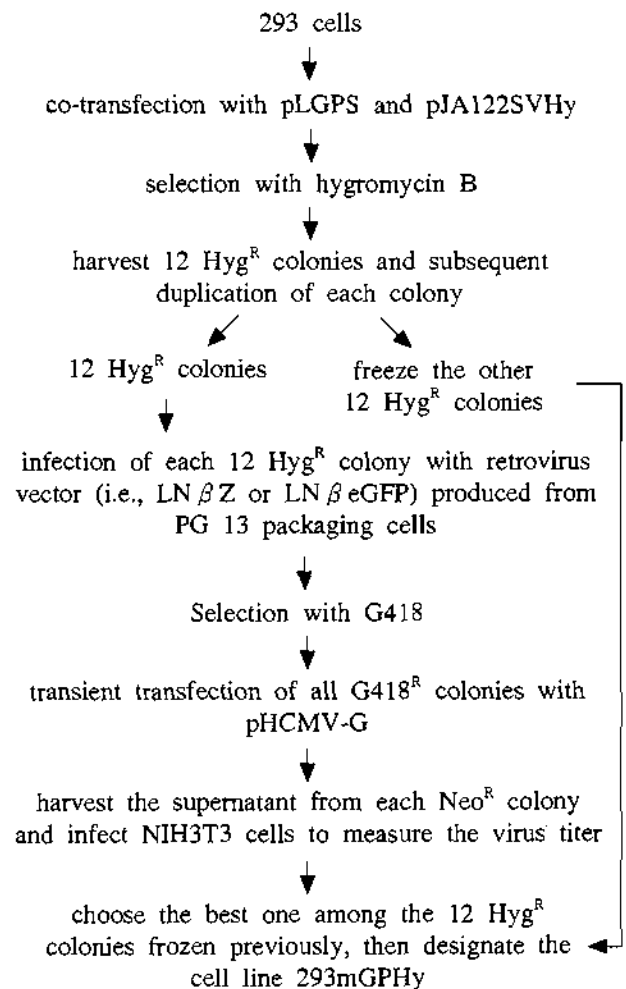

**Figure 1.** Flow diagram outlining the construction of the 293mGPHy cell line

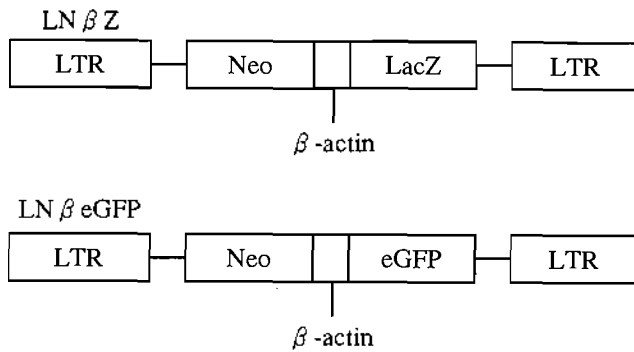

**Figure 2.** Structures of retrovirus vectors. LTR, long terminal repeat; Neo, G418 resistant gene;  $\beta$ -actin, rat  $\beta$ -actin promoter; *LacZ*, *E. coli*  $\beta$ -galactosidase gene; eGFP, enhanced Green Fluorescent protein gene. Drawings are not to scale but detailed structure of the pLN $\beta$ Z can be found at Kim et al. (1993b). The pLN $\beta$ eGFP was constructed by replacing the *LacZ* gene fragment of the pLN $\beta$ Z with eGFP fragment derived from 780 bp *Hind III*-*Not I* fragment of pEGFP-N1 purchased from Clontech.

#### Concentration of virus

The medium harvested from the virus-producing cells was centrifuged to pellet the viruses at  $50,000\times g$  for 90 minutes at  $4^{\circ}\text{C}$  using vertical rotor (Beckman 70Ti). Following complete removal of supernatant after centrifugation, the pellet was placed at  $4^{\circ}\text{C}$  overnight with small volume of 0.1X Hank's Balanced Salt Solution (HBSS,<sup>4</sup> Yee et al., 1994) for suspension. For 1,000X concentration, virus stock of the first concentration cycle was pooled and centrifuged a second time. The concentrated virus stock was filtered through  $0.22\ \mu\text{m}$  pore-size filter before storage in aliquots at  $-70^{\circ}\text{C}$ .

#### Infection of target cells

Infection of target cells was performed following our established protocol (Kim et al., 1993a, b); 4 ml of a mixture of fresh non-selection medium, various amounts of virus-containing medium (filtered through  $0.22\ \mu\text{m}$  pore-size filter), and polybrene ( $5\ \mu\text{g/ml}$  final concentration) were added to target cells which were plated on the previous day. Addition of selection medium (G418), X-gal staining or GFP assay of the cells was done on the next day after splitting.

#### Chicken embryo infection

To locate the blastoderm, fertilized eggs were placed at room temperature overnight. Shells were removed from the area above the blastoderm of unincubated eggs (Bosselman et al., 1989), and  $10\ \mu\text{l}$  of virus stock supplemented with polybrene ( $10\ \mu\text{g/ml}$ ) was injected beneath the blastoderm. Eggs were

resealed with paraffin film and allowed to hatch at  $37.7^{\circ}\text{C}$  in a rotating humidified incubator.

#### $\beta$ -galactosidase and GFP assays for infected cells and chicken embryos

Expression of the *E. coli LacZ* genes in the infected cells was evaluated by X-gal staining following the procedure of Sanes et al. (1986). A similar protocol was employed for X-gal staining of chicken embryos but fixation, washing and staining were done for 2 days each. Expression of GFP gene was determined by epifluorescence microscopy using FITC (fluorescein isothiocyanate) filter cube

#### Examination of helper virus production

1 ml of medium taken from the Neo<sup>R</sup> target cells after infection and selection steps was filtered and applied to the PG13 packaging cells with polybrene. After 2 days of culture, 1 ml of the filtered medium from the PG13 cells was added to HeLa cells and selected with G418 ( $800\ \mu\text{g/ml}$ ) for 2 weeks.

## RESULTS

#### Construction of 293mGPHy cells expressing *gag* and *pol* genes

To construct 293mGPHy cells, as described in materials and methods, 293 cells were co-transfected with pLGPS and pJZ122SVHy carrying the genes of MoMLV *gag-pol* and Hyg<sup>R</sup>, respectively. At the initial trials, following the standard approach of most publications (Burns et al., 1993; Pear et al., 1993), we did RT (reverse transcriptase) assay (Kim et al., 1993b) to select the colonies expressing the *gag* and *pol* genes after hygromycin B selection. One of the main problems we confronted, however, was failure of virus production from most of the RT<sup>+</sup> colonies that had undergone introductions of sequences for both retrovirus vector and VSV-G gene. Unexpectedly, we observed unhealthy morphology and slow proliferation of the cells expressing high RT activity, indicating presumable cytotoxic effect of RT in 293 cells, eventually resulting in inability of virus production. Not to be discouraged by the artifact of RT assay, we tried to select the best *gag-pol*<sup>+</sup> colony in terms of virus-production as summarized in figure 1. Among twelve actively proliferating Hyg<sup>R</sup> colonies we tested, only two colonies produced viruses and the better one in virus production was named 293mGPHy.

#### Infectivity and stability of the retrovirus vectors packaged with VSV-G

The medium taken from the Neo<sup>R</sup> (G418 resistant) 293mGPHy cells expressing LN $\beta$ Z (figure 2) provirus and the VSV-G gene was concentrated ultracentrifugally and applied to the EBTr target cells

**Table 1.** Titer comparisons of the LN $\beta$ Z viruses produced from PG13 and 293mGPHy/VSV-G packaging cell lines

Packaging cell	Neo <sup>R</sup> CFU/ml <sup>b</sup>		LacZ <sup>+</sup> TU/ml <sup>c</sup>	
	1X concentration	1,000X concentration	1X concentration	1,000X concentration
PG13	$1.4 \times 10^5$	$6.3 \times 10^6$ (45X) <sup>d</sup>	$5.1 \times 10^4$	$2.2 \times 10^6$ (43X) <sup>d</sup>
293mGPHy/VSV-G <sup>a</sup>	$6.1 \times 10^5$	$8.7 \times 10^7$ (143X) <sup>d</sup>	$2.3 \times 10^5$	$3.1 \times 10^7$ (135X) <sup>d</sup>

EBTr cells were infected with LN $\beta$ Z viruses encapsidated with either GaLV envelope (from PG13 cell) or VSV-G (from 293mGPHy/VSV-G cell). Mean titers presented here determined from three repeated experiments each with three observations.

<sup>a</sup> 293mGPHy/VSV-G refers to 293mGPHy cells expressing VSV-G gene.

<sup>b</sup> Neo<sup>R</sup> CFU/ml refers to G418 resistant colony forming unit per ml. After infection of the EBTr target cells, 14 days of G418 selection was done to count Neo<sup>R</sup> colony number.

<sup>c</sup> LacZ<sup>+</sup> TU/ml refers to LacZ<sup>+</sup> transforming unit per ml. After infection, the X-gal staining of the EBTr target cells was done on the next day of splitting.

<sup>d</sup> Numbers in the parentheses indicate folds of titer increase after 1,000X concentration.

to measure the titer. Comparisons of the titer were made with the same retrovirus vectors encapsulated with Gibbon ape leukemia virus envelope protein by PG13 packaging cells (Miller et al., 1991). PG13 packaging cell line has been one of the most popular cell lines in retrovirus-mediated gene transfer experiments. Titers were measured by both Neo<sup>R</sup> colony forming unit per milliliter (CFU/ml) and LacZ<sup>+</sup> positive transforming units per milliliter (LacZ<sup>+</sup> TU/ml). Based on both Neo<sup>R</sup> CFU/ml and LacZ<sup>+</sup> TU/ml titers as shown in table 1, the viruses packaged from 293 mGPHy/VSV-G cells were at least four times more infectious to bovine EBTr cells than those packaged from PG13 cells ( $p < 0.0001$ ) as analyzed by Analysis of Variance by using General Linear Model (GLM). 1,000X concentration of the viruses produced from PG13 packaging cells resulted in 45X and 43X increases in Neo<sup>R</sup> (G418 resistant) CFU/ml and LacZ<sup>+</sup> TU/ml titers, respectively. In the case of the viruses produced from 293 mGPHy/VSV-G packaging cells, 1,000X concentration resulted in 143X and 135X increases in G418<sup>R</sup> CFU/ml and LacZ<sup>+</sup> TU/ml titers, respectively.

Using another retrovirus vector LN $\beta$ eGFP (figure 2), a similar experiment was done to confirm the data in table 1. The main difference between LN $\beta$ eGFP and LN $\beta$ Z is the second reporter gene under the rat  $\beta$ -actin promoter. LN $\beta$ eGFP contains GFP gene instead of the *E. coli* LacZ gene of the LN $\beta$ Z (figure 2). As we have already observed with the LN $\beta$ Z viruses in table 1, the LN $\beta$ eGFP viruses packaged from 293mGPHy/VSV-G cells were more infectious to bovine EBTr cells than those packaged from PG13 cells ( $p < 0.0001$ ) from an analysis of variance using GLM (table 2). Stability of the viruses after ultracentrifugation is more significant in LN $\beta$ eGFP viruses encapsidated with VSV-G. A 1,000X concentration of the viruses produced from either PG13 or 293mGPHy/VSV-G packaging cells increased

the titer as high as 132X or 1,034X, respectively, indicating VSV-G protein's ability to withstand centrifugal shearing stress. Counting of GFP<sup>+</sup> cell number was not performed because of technical difficulty in epifluorescence microscopy, but numerous prominent green cells due to the GFP gene expression was observed through FITC (fluorescein isothiocyanate) filter cube (data not shown).

#### Infectivity of LN $\beta$ Z and LN $\beta$ eGFP retrovirus vectors encapsidated with VSV-G to the human target cells

Further investigation was made to evaluate the utilization of our VSV-G pseudo-typed retrovirus vector system to human gene therapy. HeLa cells were

**Table 2.** Titer Comparisons of the LN $\beta$ eGFP viruses produced from PG13 and 293mGPHy/VSV-G packaging cell lines

Packaging cell	Neo <sup>R</sup> CFU/ml <sup>b</sup>	
	1X concentration	1,000X concentration
PG13	$1.9 \times 10^5$	$2.5 \times 10^7$ (132X) <sup>c</sup>
293mGPHy/VSV-G <sup>a</sup>	$2.9 \times 10^5$	$3.0 \times 10^8$ (1,034X) <sup>c</sup>

LN $\beta$ eGFP viruses encapsulated with either GaLV (from PG13 cell) or VSV-G (from 293mGPHy/VSV-G cell) infected EBTr target cells. Each titer was determined from the average number of G418 resistant colonies of three experiments and three dishes of EBTr cells were infected each time.

<sup>a</sup> 293mGPHy/VSV-G refers to 293mGPHy cells expressing VSV-G gene.

<sup>b</sup> Neo<sup>R</sup> CFU/ml refers to G418 resistant colony forming unit per ml. After infection of the EBTr target cells, 14 days of G418 selection was done to count Neo<sup>R</sup> colony number.

<sup>c</sup> Numbers in the parentheses indicate folds of titer increase after 1,000X concentration.

chosen as target cells and infectivity was measured with  $\text{Neo}^R$  CFU/ml and  $\text{LacZ}^+$  TU/ml. Surprisingly, the numerical values of both  $\text{Neo}^R$  CFU and  $\text{LacZ}^+$  TU were around  $10^{10}$  in milliliter of concentrated supernatant. This result implies that VSV-G pseudotyped retrovirus system must significantly facilitate the study of human gene therapy.

#### Infection of chicken embryos with the retrovirus vectors

Encouraged with previous results, we tested another possibility of transgenic chicken production using our VSV-G based virus vector system. As a preliminary experiment, pre- or post-concentrated LN $\beta$ Z (figure 2) virus stocks were applied to the CEF cells and counted the number of  $\text{Neo}^R$  colonies after two weeks of selection with G418 (600  $\mu$ g/ml). Titers of the pre- and post-concentrated virus stocks were about  $1.0 \times 10^5$  and  $1.0 \times 10^8$  G418R CFU/ml, respectively (data not shown).

To infect chicken embryos with the same retrovirus vectors, 10  $\mu$ l of pre-concentrated or 100X post-concentrated virus stock was injected beneath the blastoderm. As shown in table 4, even the embryos injected with pre-concentrated virus stock were all LacZ positive (figure 3).

#### Test of helper virus production

After all the experiments described so far, we tested whether replication-competent helper viruses were produced from virus-producing cells. To do so, we added PG13 packaging cells with polybrene and 1 ml of the medium harvested from the  $\text{Neo}^R$  target cells that had undergone infection with the retrovirus vectors and selection with G418. After 2 days of culture, 1 ml of the filtered medium taken from the PG13 cells was added to HeLa cells. No  $\text{Neo}^R$  colony was found after 2 weeks of selection with G418, indicating no helper virus production from the both virus-producing cells derived from PG13 and 293 mGPHy cells.

## DISCUSSION

To increase concentration of retrovirus stock, we developed a new retrovirus vector system from which the progeny viruses were encapsulated with VSV-G. Compared to the conventional retrovirus vectors encapsulated with Gibbon ape leukemia virus envelope protein, our pseudotyped retrovirus vectors were not only more infectious to bovine embryonic cells but also more efficiently concentrated centrifugally (table 1). Recovery rate of the viruses after concentration seems to vary depending on retrovirus vector structure. In case of LN $\beta$ Z retrovirus vector designed to express  $\text{Neo}^R$  and *E. coli* LacZ genes, recovery rate

was calculated around 14.3% (143/1,000). When LN $\beta$ eGFP retrovirus vector carrying  $\text{Neo}^R$  and GFP genes was tested, however, 100% (1,034/1,000) recovery of

**Table 3.** Titers of the concentrated VSV-G pseudotyped retrovirus vectors on the HeLa target cells

Virus vector	$\text{Neo}^R$ CFU/ml <sup>a</sup>	$\text{LacZ}^+$ TU/ml <sup>b</sup>
LN $\beta$ Z	$1.23 \times 10^{10}$	$6.03 \times 10^9$
LN $\beta$ eGFP	$7.05 \times 10^9$	N/A <sup>c</sup>

LN $\beta$ Z or LN $\beta$ eGFP viruses encapsidated with VSV-G glycoprotein were concentrated (1,000X), then applied to HeLa target cells. Each titer is the average G418 resistant or LacZ-expressing cell number of triple target cell samples.

<sup>a</sup>  $\text{Neo}^R$  CFU/ml refers to G418 resistant colony forming unit per ml. After infection of the EBTr target cells, 14 days of G418 selection was done to count  $\text{Neo}^R$  colony number.

<sup>b</sup>  $\text{LacZ}^+$  TU/ml refers to  $\text{LacZ}^+$  transforming unit per ml. After infection, the X-gal staining of the EBTr target cells was done on the next day of splitting.

<sup>c</sup> N/A; not applicable, because LN $\beta$ eGFP carries GFP gene instead of LacZ gene. GFP<sup>+</sup> TU/ml was not numerically measured due to technical difficulties.

**Table 4.** Efficiency of gene transfer to chicken embryos

Medium	No. of eggs injected	No. of eggs surviving until 20 days of incubation	No. of LacZ+ embryos
pre-concentrated	12	8	8
post-concentrated	10	6	6

To each freshly laid egg, 10  $\mu$ l of pre- or 100X post-concentrated virus stock was injected beneath the blastoderm, then incubated for 20 days before X-gal staining.



**Figure 3.** A  $\text{LacZ}^+$  embryo stained with X-gal at 21th day of incubation. Infection with LN $\beta$ Z retrovirus vector was made just before incubation. Left, a non-infected control; Right, an infected embryo expressing the *E. coli* LacZ gene.

infectious viruses resulting in the titer of  $3 \times 10^8$  CFU/ml was observed (table 2). With this concentrated virus stock, we are trying to do gene transfer to bovine oocytes by injecting the virus to the perivitelline space. Chan et al. (1998) reported that injection of concentrated retrovirus vector stock into the perivitelline space of metaphase II oocyte rather than fertilized early embryo could increase gene transfer efficiency to 100%. Based on our rough estimation, injection of only 30 picoliter of our virus stock ( $3 \times 10^8$  CFU/ml) must guarantee introduction of at least a single infectious unit per oocyte, and the volume of perivitelline space (about 280 picoliter) is enough for that injection.

Host range of our pseudotyped retroviruses extended to human cells. On HeLa target cells, the titers of the pseudotyped viruses were in excess of  $10^{10}$  infectious particles per milliliter of supernatant concentrated to 1/1,000 of the original volume. It was reported that the retrovirus vectors encapsulated VSV-G were significantly more resistant to human complement than commonly used amphotropic vectors (Ory et al., 1996). Therefore, the availability of this pseudotyped retrovirus vector system should facilitate transgenic animal production as well as human gene therapy.

One report argued that high titer of the VSV-G pseudotyped retrovirus vector system was not due to real gene transfer to the target cell genome but caused by carry-over of the reporter gene product encapsidated by VSV-G (Liu et al., 1996). Focusing on LacZ<sup>+</sup> TU/ml titer only, it might be suspected that the carry-over exaggerated the titer, because X-gal staining for LacZ<sup>+</sup> cells was done in 48 hours post-infection. In case of Neo<sup>R</sup> CFU/ml titer, however, more than 10 days are required for the count of Neo<sup>R</sup> colonies. For this reason, it is very unlikely that the gene products carried over to the target cells can be effective for more than 10 days. In addition, considering similar numbers of Neo<sup>R</sup> CFU/ml and LacZ<sup>+</sup> TU/ml titers, the argument of carry-over of the reporter gene product by VSV-G seems to be incorrect.

In transgenic chicken production, there are three targets for gene transfer: blastoderm of unincubated egg (Thoraval et al., 1995), primordial germ cell (Naito et al., 1998), and fertilized ova at the single cell stage (Sang et al., 1998). Among them, targeting the blastoderm of unincubated egg must be the easiest way but coping with numerous embryonic cells (Kochav et al., 1980) in the freshly laid eggs has been the major problem for the efficient gene transfer. In this report, using high-titered VSV-G-based retrovirus vector system, we successfully demonstrate transgenic chicken embryo expressing *E. coli* LacZ gene (figure 3). Surprisingly, all the embryos injected

with even pre-concentrated virus stock were LacZ<sup>+</sup> with 100% efficiency (table 4). The similar result was reported by Bosselman et al. (1989). They presented the data of high gene transfer efficiency with the virus stock containing  $10^4$  infectious virus particles per ml, even though most of the embryos proved to be chimeras. We expect that post-concentrated virus stock must contribute to decrease in chimerism. Comparison of pre-concentrated virus stock to post-concentrated one in terms of chimerism level is under investigation. We are also trying a new retrovirus vector carrying tetracycline-mediated controllable promoter (Iida et al., 1997) in transgenic chicken production to minimize possible biological cost due to constitutive expression of the transgene.

#### ACKNOWLEDGEMENT

This study was supported in part by C-TRI (ChemTech Research Incorporation) in Korea. We thank Dr. A. D. Miller, Dr. J. C. Burns and Dr. J. Zhang for generous provisions of PLGPS, pHCMV-G and pJZ122SVHy, respectively.

#### REFERENCES

- Bosselman, R. A., R.-Y. Hsu, T. Boggs, S. Hu, J. Bruszewski, S. Ou, L. Souza, L. Kozar, F. Martin, M. Nicolson, W. Rishell, J. A. Schultz, K. M. Semon and G. Stewart. 1989. Replication-defective vectors of reticuloendotheliosis virus transduce exogenous genes into somatic cells of the unincubated chicken embryo. *J. Virol.* 63:2680-2689.
- Burns, J. C., T. Friedmann, W. Driver, M. Burrascano and J.-K. Yee. 1993. Vesicular stomatitis virus G glycoprotein pseudotyped retroviral vectors: Concentration to very high titer and efficient gene transfer into mammalian and nonmammalian cells. *Proc. Natl. Acad. Sci. USA.* 90:8033-8037.
- Chan, A. W. S., E. J. Homan, L. U. Ballou, J. C. Burns and R. D. Bremel. 1998. Transgenic cattle produced by reverse-transcribed gene transfer in oocytes. *Proc. Natl. Acad. Sci. USA.* 95:14028-14033.
- Iida, A., S.-T. Chen, T. Friedmann and J.-K. Yee. 1996. Inducible gene expression by retrovirus-mediated transfer of a modified tetracycline-regulated system. *J. Virol.* 70:6054-6059.
- Kim, T., M. L. Leibfried-Rutledge and N. L. First. 1993a. Gene transfer into bovine cells and embryos using replication-defective retroviral vectors encapsidated with xenotropic murine leukemia virus envelopes. *Animal Biotechnology.* 4:53-69.
- Kim, T., M. L. Leibfried-Rutledge and N. L. First. 1993b. Gene transfer bovine blastocysts using replication-defective retroviral vectors packaged with Gibbon-ape leukemia virus envelopes. *Mol. Reprod. and Develop.* 35:105-113.
- Kochav, S., M. Ginsburg and H. Eyal-Giladi. 1980. From cleavage to primitive streak formation: A complementary normal table and a new look at the first stages of the

- development of the chick. *Developmental Biol.* 79:296-308.
- Liu, M.-L., B. L. Winther and M. A. Kay. 1996. Pseudotransduction of hepatocytes by using concentrated pseudotyped vesicular stomatitis virus G glycoprotein (VSV-G)-Moloney leukemia virus-derived retrovirus vectors: Comparison of VSV-G and amphotropic vectors for hepatic gene transfer. *J. Virol.* 70:2497-2502.
- Miller, A. D. and C. Buttimore. 1986. Redesign of retrovirus packaging cell lines to avoid recombination leading to helper virus production. *Mol. Cell Biol.* 6:2895-2902.
- Miller, A. D., J. V. Garcia, N. von Suhr, C. M. Lynch, C. Wilson and M. V. Eiden. 1991. Construction and properties of retrovirus packaging cells based on Gibbon ape leukemia virus. *J. Virol.* 65:2220-2224.
- Muramatsu, T., H. M. Park and J. Okumura. 1998. Current status and perspectives on *in vivo* gene transfer to avian species. In: *Proceedings 6th Asian Pacific Poultry Congress, Nagoya*. pp. 42-47.
- Naito, M., M. Sakurai and T. Kuwana. 1998. Expression of exogenous DNA in the gonads of chimaeric chicken embryos produced by transfer of primordial germ cell transfected *in vitro* and subsequent fate of the introduced DNA. *J. Repro. Fertil.* 113:137-143.
- Olsen, J. C. and J. Sechelski. 1995. Use of sodium butyrate to enhance production of retroviral vectors expressing CFTR cDNA. *Hum. Gen. Ther.* 6:1195-1202.
- Olsen, J. C., L. G. Johnson and J. R. Yankaskas. 1994. Methods for the use of retroviral vectors for transfer of the CFTR gene to airway epithelium. In: *Gene Therapy Protocols* (Ed. P. D. Robbins). Humana Press, Totowa, New Jersey, USA. pp. 153-168.
- Ory, D. S., B. A. Neugeboren and R. C. Mulligan. 1996. A stable human-derived packaging cell line for production of high titer retrovirus/vesicular stomatitis virus pseudotypes. *Proc. Natl. Acad. Sci. USA.* 93:11400-11406.
- Pear, W. S., G. P. Nolan, M. L. Scott and D. Baltimore. 1993. Production of high-titer helper free retroviruses by transient transfection. *Proc. Natl. Acad. Sci. USA.* 90:8392-8396.
- Sanes, J. R., J. L. R. Rubenstein and J. F. Nicolas. 1986. Use of a recombinant retrovirus to study post-implantation cell lineage in mouse embryos. *EMBO.* 5:3133-3142.
- Sang, H. M., C. M. Mather, R. Mitchel, Y. Li and A. Sherman. 1998. Recent developments in the production of foreign proteins in the egg yolk and albumen by the transgenic hens. In: *Proceedings 6th Asian Pacific Poultry Congress, Nagoya*. pp. 48-51.
- Thoraval, P., M. Afanassieff, F. L. Cosset, F. Lasserre, G. Verdier, F. Coudert and G. Dambrine. 1995. Germline transmission of exogenous genes in chickens using helper-free ecotropic avian leucosis virus-based vectors. *Transgenic Res.* 4:369-377.
- Yee, J.-K., T. Friedmann and J. C. Burns. 1994. Generation of high-titer pseudotyped retroviral vectors with very broad host range. *Methods in Cell Biol.* 43:99-112.