

# Information Packaging in HPSG

Jong-Bok Kim  
School of English  
Kyung Hee University  
jongbok@nms.kyunghee.ac.kr

한국언어정보학회 2000년 학술대회  
조선대학교, 사회복지관  
June 29-30, 2000

## 1 Information Packaging and Its role in the Grammar

- The characteristics of IS in HPSG developed by Engdahl and Vallduví (1996):
  1. IS (information structure) is an integral part of grammar since it interacts in principled ways with both syntax and phonology
  2. The representation of IS in the grammar is independent of its particular structural realization in different languages (cf. English by prosody and Catalan by syntactic position)
- What is IS?

It is a structuring of sentences by syntactic, prosodic, or morphological means that arises from the need to meet the communicative demands of a particular context. In particular, IS indicates how linguistically conveyed information fits into the hearer's information state at the time of utterance.
- The role of IS in sentences: no proper focus/ground partitioning would result in infelicitious answers.
  - (1) A: What does he hate?  
B: He hates CHOCOLATES.  
B: #He HATES chocolate.
  - (2) A: Does John LIKE rugby?  
B: No, he HATES rugby.  
B: #No. he hates RUGBY.
- Sentence structure with IS:

(3) S = {focus, ground}

ground = {link, tail}

1. Focus: the new information that the speaker wants to convey; the “informative” part (actual information part) that makes some contribution to the discourse or the hearer’s mental world; A-accented (H\*)
2. Ground: the material that is assumed to be already known to the hearer; the part that anchors the sentence to the previous discourse or the hearer’s mental world
3. Link: This is what the sentence is about, similar to Topic in traditional terms; B-accented (L+H\*)
4. Tail: The rest of the ground or the given information which is somewhat inconspicuous (not prominent) in the sentence; no accent

• English examples

(4) A: What do the boys DO?

B: John [<sub>F</sub> plays RUGBY], Bill [<sub>F</sub> goes SAILING], and ...

(5) A: What do the boys PLAY?

B: [<sub>L</sub> John] [<sub>T</sub> plays] [<sub>F</sub> RUGBY], [<sub>L</sub> Bill] [<sub>T</sub> plays] [<sub>F</sub> HOCKEY].

(6) New White House Butler: So tell me about the people in the White House. Anything I should know?

Presidential Aid: Yes. [<sub>L</sub> The president][<sub>F</sub> hates the Delft CHINA SET]. Don’t use it.

(7) Foreign Secretary: In the Netherlands I got a big Delft China tray that matches the set in the living room. Was that a good idea?

Presidential Aid: Maybe. [<sub>L</sub> The president] [<sub>F</sub> HATES] [<sub>T</sub> the Delft china set] (but the first lady LIKES it.)

## 2 IP in HPSG

### 2.1 Characteristics of HPSG

- All linguistic expressions are units of information, simultaneously specified in various dimensions
- These multidimensional units are signs which are represented as feature structures
- Basic structure of signs

PHONOLOGY <i>list</i>
CATEGORY <i>syntactic-object</i>
CONTENT <i>semantic-object</i>
CONTEXT <i>contextual-object</i>

- Some context information:

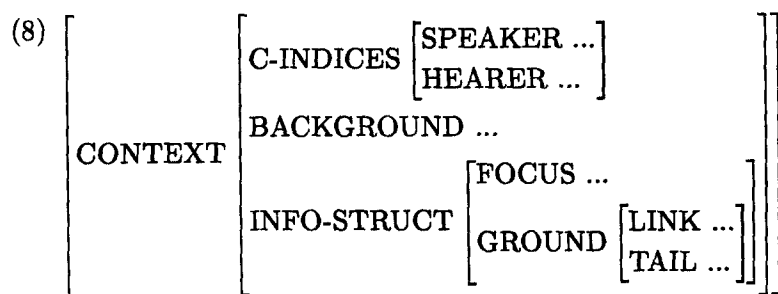

1. C-INDICES (contextual indices): speaker and hearer will be anchored to the actual speaker and hearer of the utterance.
2. BACKGROUND: contain relevant contextual information which may play a role in resolving potential ambiguities, establishing reference and interpreting elliptical utterances
3. INFO-STRUCT: structure-shared with the SYNSEM (in E&V 1996)<sup>1</sup> of the words or phrases that realise the focus, link and tail respectively.

- Constraints in English

- (9) a. FOCUS realization:



- b. Link realization:



- c. Unmarked accent: no value of INFO-STRUCT is specified.

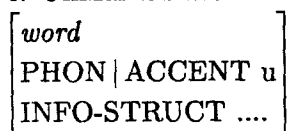

- INFO-STRUCT Instantiation Principles for English

- (10) Either (i) if a DAUGHTER's INFO-STRUCT is instantiated, then the mother inherits this instantiation (for narrow foci, links and tails),

or (ii) if the most oblique DAUGHTER's FOCUS is instantiated, then the FOCUS of the mother is the sign itself (wide focus).

<sup>1</sup>In Engdahal (1999), this value is CONTENT.

- True Examples:

1. Narrow Object Focus:

(11)

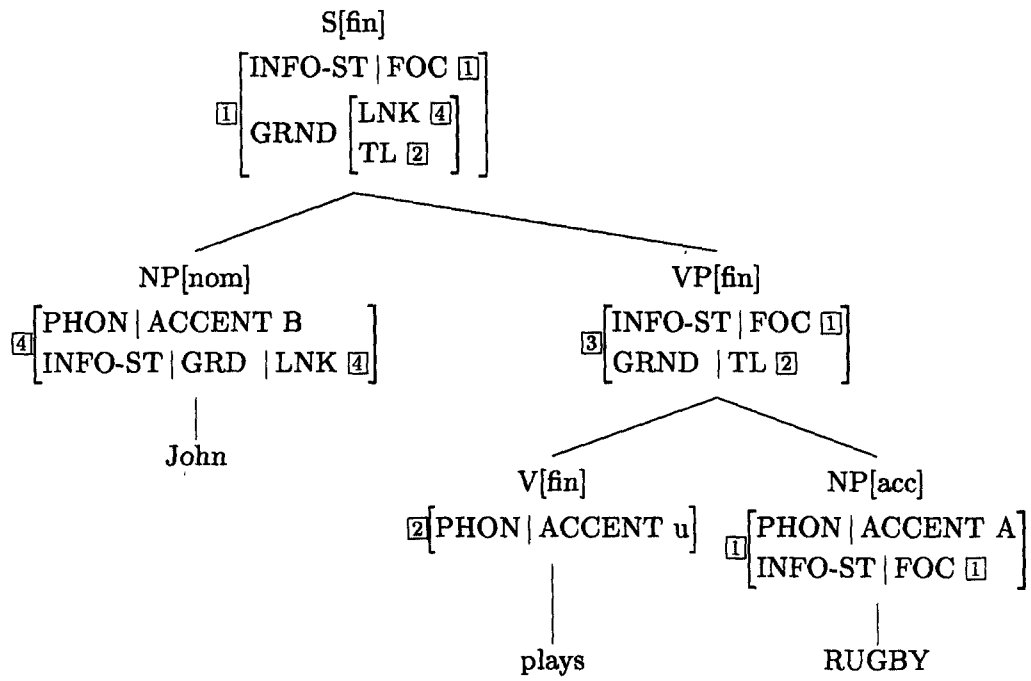

2. Wide VP focus

(12)

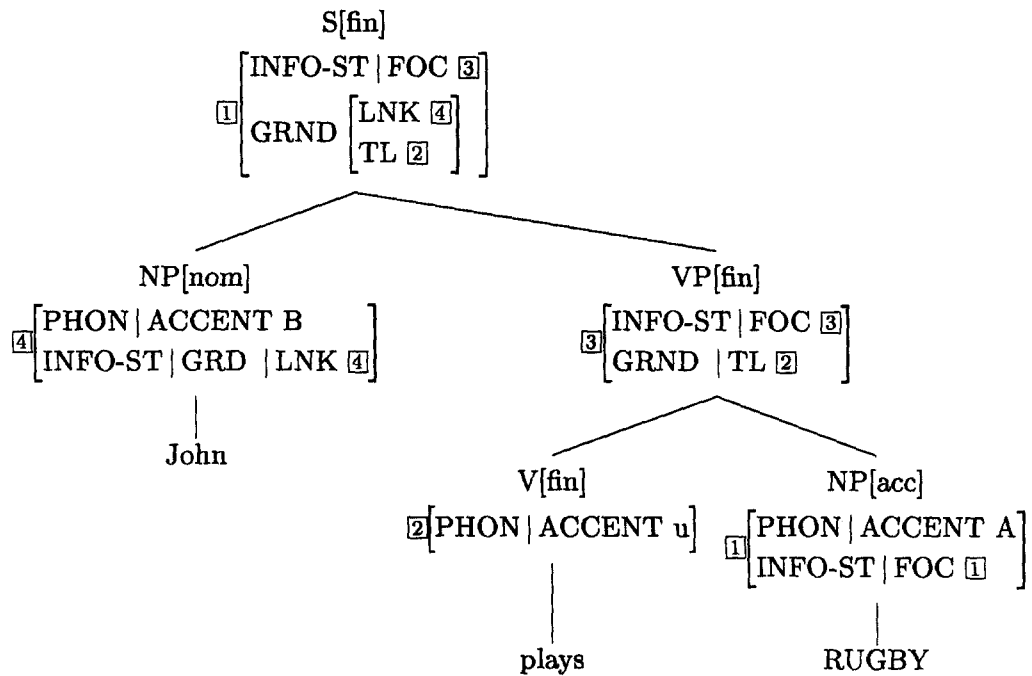

• Other predictions

1. Bresnan (1971): Focus projection is only possible if the A-accented item is the peripheral one (cf. (10)ii).

- (13) a. The butler [<sub>F</sub> offered the president some COFFEE].  
 b. \*The butler [<sub>F</sub> offered the PRESIDENT some coffee].  
 c. The butler offered [<sub>F</sub> the PRESIDENT] some coffee.

2. Verb Focus

(14) The president [<sub>F</sub> HATES] the Delft china set.

(15)

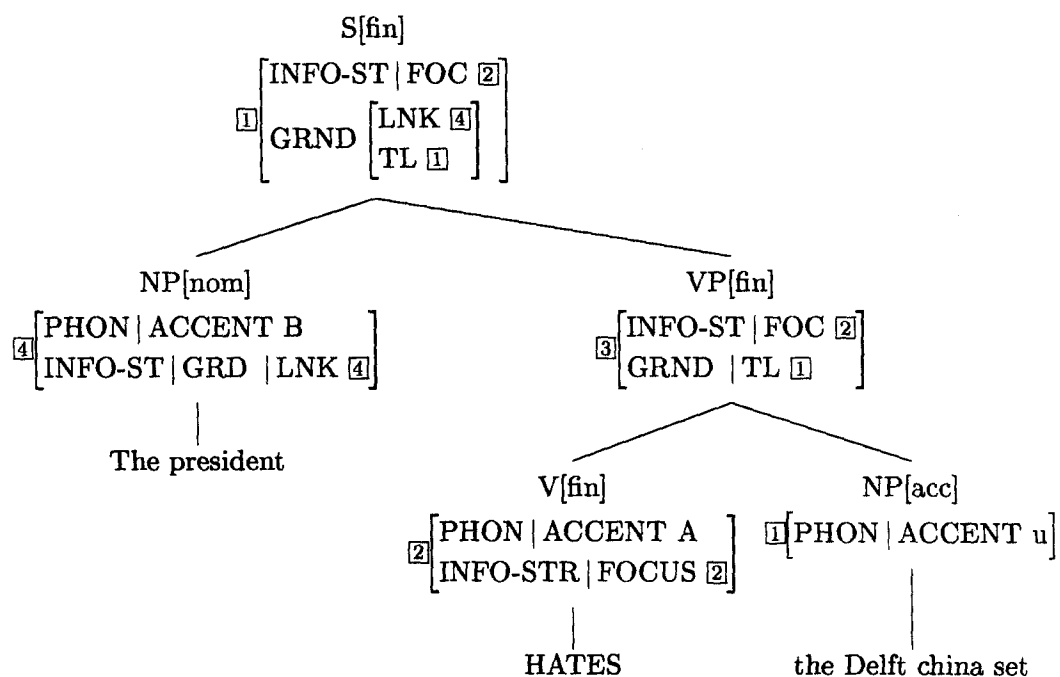

3. Subject-verb focus: mismatch between informational partitioning and syntactic constituency

- (16) A: What happened to the china set?  
 B: [The BUTLER BROKE] the set.

(17)

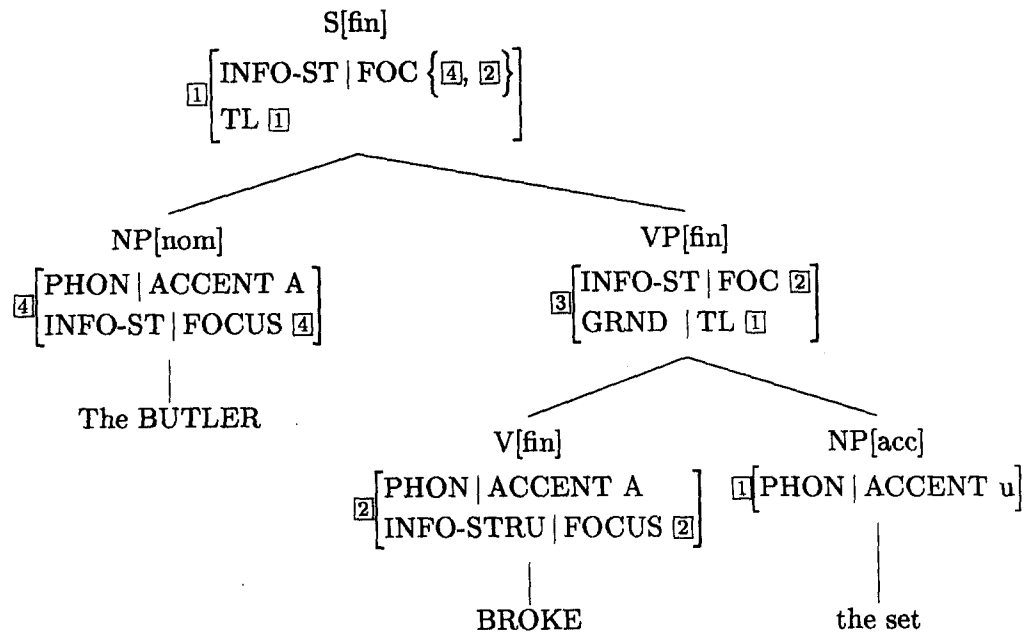

#### 4. complex focus (multiple foci)

- (18) A: Who did your friends introduce to whom?  
B: John introduced BILL to SUE, and Mike....

### 3 Information Packaging in Korean

#### 3.1 Morphological Marking

- Topic marker *un*

##### 1. Can mark a Link Phrase

- (19) [<sub>L</sub> Onul-un] nalssi-ka      coh-ta  
Today-TOP weather-NOM good-DECL  
'As for today, the weather is good.'

(20)

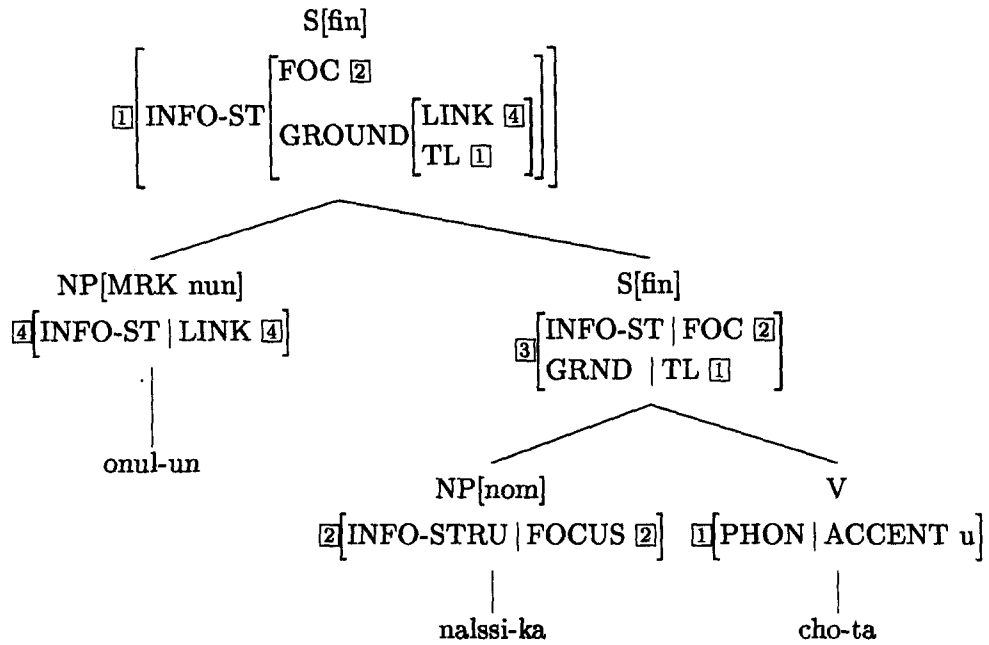

2. Can mark a contrastive focus

(21) John-i ecye [<sub>F</sub> sakwa-nun] mekess-ta  
 John-NOM yesterday apple-TOP ate-DECL  
 'John ate apples yesterday but not other fruits.'

(22)

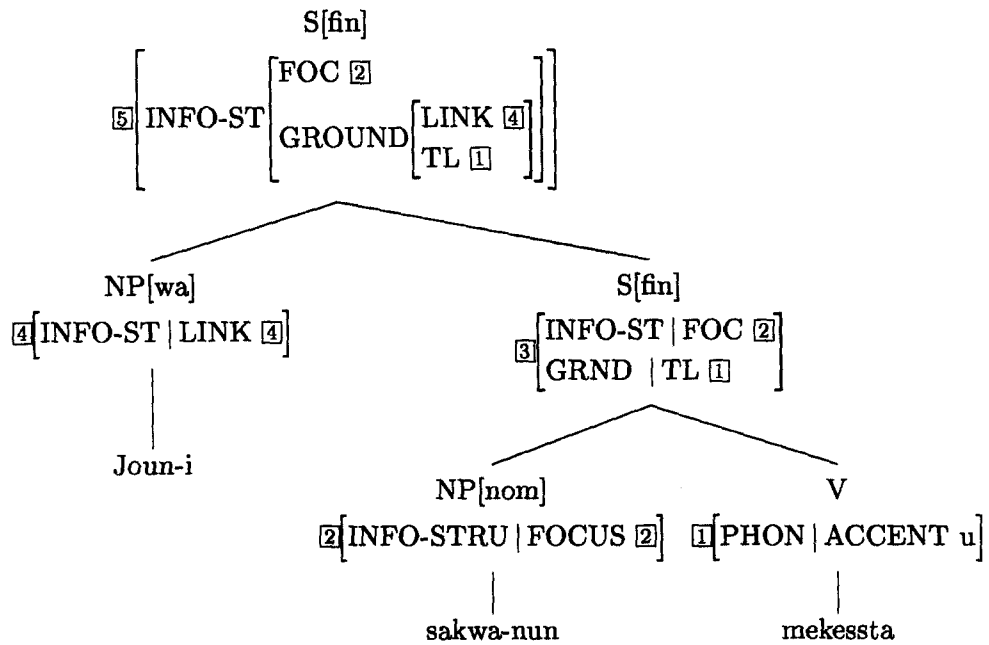

- Subject Marker *ka*:

1. Can mark a narrow focus

- (23) [<sub>F</sub> John-i] sakwa-lul mek-ess-ta  
 John-NOM apple-ACC eat-ess-DECL  
 'It is John who ate apples.'

2. Can mark a wide focus: Presentational reading

- (24) [<sub>F</sub> [<sub>F</sub> John-i] sakwa-lul mek-ko iss-ta]  
 John-NOM apple-ACC eat-COMP in.state-DECL  
 'There is John eating apples.'

(25)

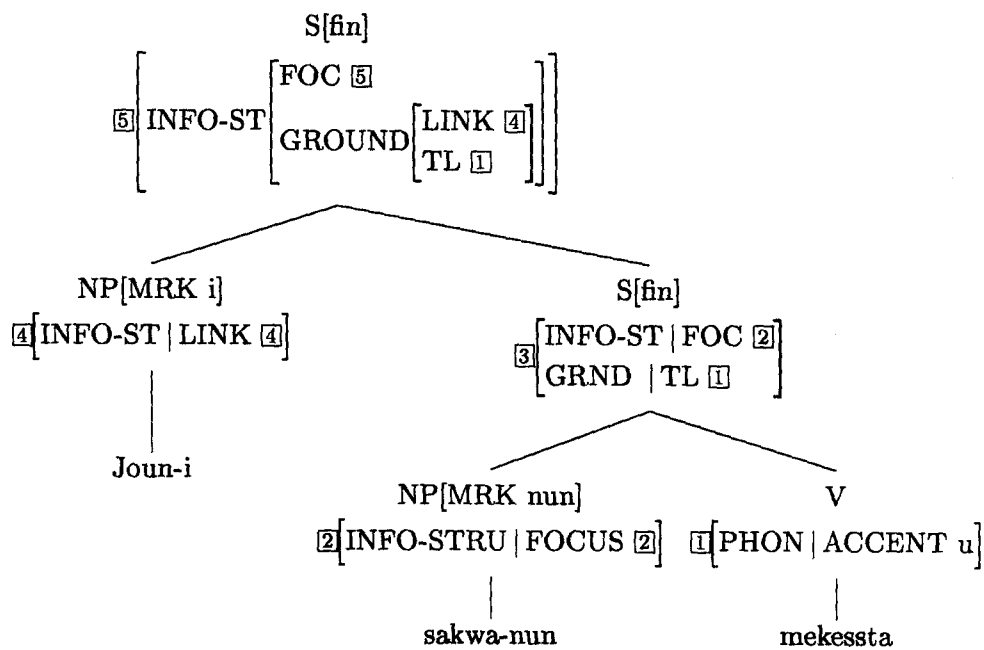

- INFO-STRUCT Instantiation Principles for Korean

(26) Either (i) if a DAUGHTER's INFO-STRUCT is instantiated, then the mother inherits this instantiation,

or (ii) if the subject's FOCUS is instantiated, then the FOCUS of the mother is the sign itself (wide focus).

3. Can even mark a link

- (27) When interpreted as John's leaving is a surprising  
 John-i ttenasse.  
 John-NOM left  
 'As for John, John left.'



### 3.2 Prosody Marking

#### 1. A-accent: focus marking

- (28) a. ONUL achim sakwa mekesse  
today morning apple ate  
'It is today that I ate apples in the morning.'  
b. onul ACHIM sakwa mekesse  
c. onul achim SAKWA mekesse  
d. onul achim sakwa MEKESSE

#### 2. B-accent: Link marking: to be tested.

### 3.3 Word Ordering Marking

#### 1. Scrambled to the front: focused

- (29) [<sub>F</sub> sakwa-lul] John-i mekessta  
apple-ACC John-NOM ate  
'It is apples that John ate.'

#### 2. post-verbal constructions: tail

- (30) sakwa-lul mekessta. [<sub>T</sub> John-i].

### 3.4 IP in Multiple Nominative Constructions

- (31) FP: JOHN-I emeni-ka coh-u-si-ta.  
John-NOM mother-NOM good-DECL  
'It is the teacher whose mother is good.'

(32)

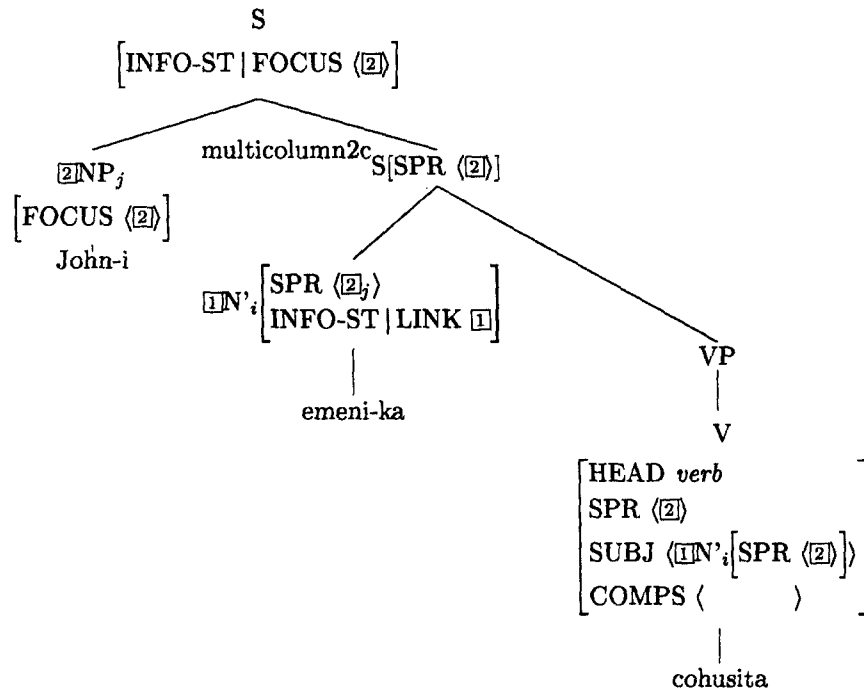

(33) a. Seoul-i yelum-i nalssi-ka tepta  
 Seoul-NOM summer-NOM weather-NOM hot  
 'It is Seoul whose summer weather is hot.'

b. John-i elkwul-i oyncok-i alay-ka aphuta  
 John-NOM face-NOM left-NOM bottom-NOM sick  
 'John is sick in the face on the right side in the bottom.'

(34)

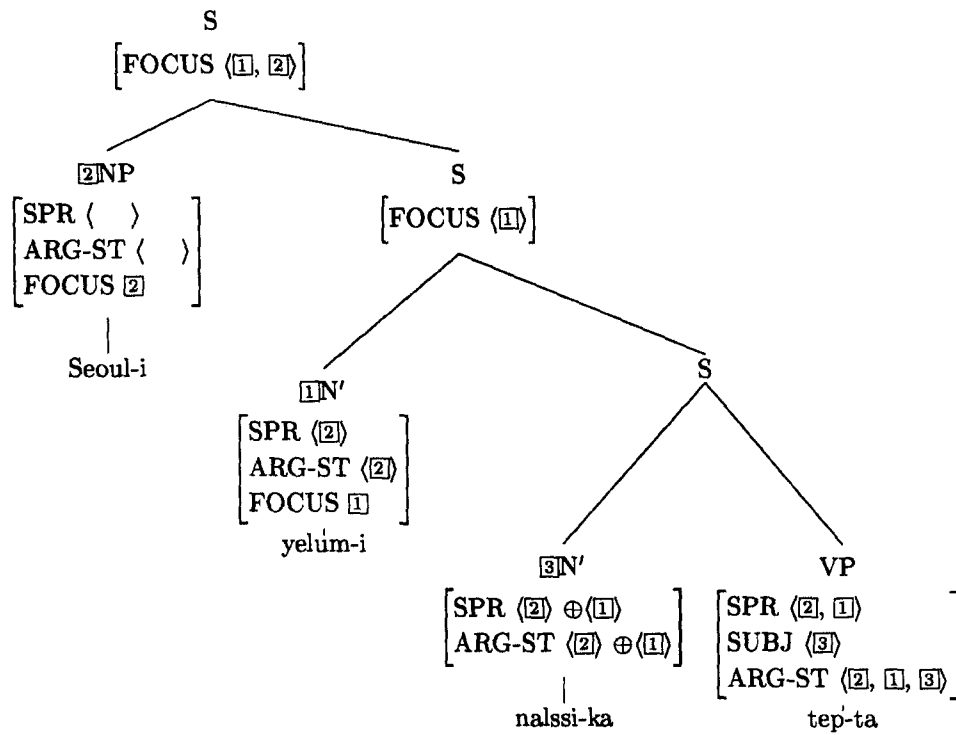

## References

- Choi, Hye-won. 1996. Optimizing Structure in Context: Scrambling and Information Structure. Ph.D. Dissertation. Stanford Univ.
- Engdahl, Elizabeth and Enric Vallduví. 1996. Information packaging in HPSG. In Claire Grover and Enric Vallduvi (eds.), *Studies in HPSG: Edinburgh Working Papers in Cognitive Science*, 1-31.
- Lee, Chungmin. 1994. Definite/Specific and Case Marking. In Kim-Renaud ed., *Theoretical Issues in Korean Linguistics*. 325-341. Stanford: CSLI Publications.
- Lee, Hong-Bae and Mi-Kyung Kim. 1988. Double-nominative constructions in Korean. In *Linguistics in the Morning Calm II*, 489-506. Seoul: Hanshin.
- Lee, Ik-Hwan. 1987. Double subject constructions in GPSG. *Harvard Studies in Korean Linguistics II*, 287-298. Seoul: Hanshin.
- O'Grady, William. 1991. *Categories and Case*. Amsterdam: John Benjamins Publishing.
- Park, Byung-Soo. 1981. Double Subject Constructions Revisited. *Linguistics in the Morning Calm*. Seoul: Hanshin.
- Rooth, M. 1992. A Theory of focus interpretation. *Natural Language Semantics*, 1: 75 - 116.
- Schütze, C. 1996. Korea 'Case Stacking' Isn't: Unifying Noncase Uses of Case Particles. *NELS* 26.
- Vallduví, Enric and Elisabet Engdahl. 1996 The linguistic realization of information packaging. *Linguistics* 34, 459-519.

- Yang, Dong-Whee. 1999. Case Features and Case Particles. In Bird et al (eds.s), *WCCFL 18*, 626–639.
- Yim, Young-Jae. 1985. Multiple subject constructions. In *Harvard Studies in Korean Linguistics*. 101-112. Hanshin: Seoul.
- Yoon, James. 1986. Some Queries concerning the syntax of multiple subject constructions in Korean. *Studies in the Linguistic Sciences*, 16: 215–236.
- Young, Jeong-Me. 1989. ECM and Multiple Subject Constructions in Korean. *Harvard Studies in Korean Linguistics III*. Seoul: Hanshin.