

Understanding Maternal Role Attainment in Taejon, Korea through the Use of a Structural Model

Lee, Hae Kyung*

Purpose and Importance

Babies are both a joy and a strain for the women who raise them. There is deep satisfaction in committing oneself to a baby and helping him or her develop into adulthood.

Motherhood brings fulfillment, pride, amusement, and joy through the relationship between a mother and a baby. Also, motherhood restricts the freedom, increases the workload, raises the monetary needs, and generally complicates and constrains the life of the mother.

A review of the literature supports the belief that the transition to motherhood depends on such factors as the nature of the event, the state of organization of the family at the point of parenting, the resources of the family, and its previous experience with crises (Gibaud-Wallston, 1977). For example, the impact of the motherhood will depend on having a normal or difficult baby; being a close-knit or differentiated couple and a supportive social support; availability of personal resources such as money, burden, time; being a skillful and competent mother.

Although most mothers accept the notion that both joy and strain are inevitable results of motherhood, it may be useful information for mothers, families, and nurses to know which variables influence maternal role strain and maternal role attainment.

This study will investigate variables which influence maternal role attainment, create a hypothetical model, and test the validity of the model on role theory in Korea. The results of this study will be used to provide knowledge needed for Korean mothers to reduce maternal role strain and thus get maternal role attainment easy.

Literature Review

1. Definition of Maternal Role Attainment

Steele and Pollack (cited in Bobak, Jensen & Zalar, 1989, p. 587) described the maternal role as one process with two components. The first role, being practical or mechanical in nature, involves cognitive and motor skills. This component includes childcare activities such as "feeding, holding, clothing, and cleaning the infant, protecting it from

* Professor of the Department of Nursing, Kangwon National University

harm, and providing mobility for it(p.587)". The second role is emotional in nature and involves cognitive and affective skills. The cognitive-affective component of the maternal role includes "motherliness" and attitudes, tenderness, awareness, and concern for the child's needs and desires(p.587). Maternal role attainment was described initially by Rubin(1967) as beginning prenatally and culminating with formation of a maternal identity during the infant's first year. Rubin(1967) and Mercer(1986) theorized a formation of a maternal identity which takes place concomitantly with role internalization. They used maternal role attainment and maternal identity almost synonymously. Elsewhere Walker, Grain and Thompson(1986a, 1986b) defined maternal identity and role performance as the two components of maternal role attainment. Because the concept of maternal role has two components, Walker's definition may be more appropriate in defining maternal role attainment.

2. Role Strain and Maternal Role Attainment

Goode(cited in Burr, Holl, Nye & Reiss, 1979) defined role strain as the "felt difficulty in fulfilling role obligations(p.57)". It is the stress generated within a person when he or she cannot comply with a role or set of roles. In a theory of role enactment (Burr, et al., 1979) that role strain effects role enactment. Majewski(1985) found that mothers who experienced more role conflict had more difficulty in the transition to the maternal role($r = .42, p < .001$). Lee(1992) studied 224 primiparous mothers at the postpartum period regarding maternal role attainment, role strain significantly effected maternal role attainment($\beta_{21} = -3.05, T = -3.127$). Studies of role strain and maternal role attainment suggested that maternal role strain, as a mediated variable, affects maternal role attainment(Roberts, 1983).

3. The Influence of Variables on Role Strain and Maternal Role Attainment

Change in Daily life : Burr et al.(1979) introduced the idea that the greater the normative change that is perceived in a role transition, the less easy the transition into the new role. Mercer(1986) reported that 58% of women found the time requirements were the most difficult at 4 months after birth.

Roberts(1983) studied 64 mothers at 4 weeks postdelivery and found the normative change was negatively related to the ease of transition to parenthood ($r = -.49, p < .001$). Lee(1992) studied 224 primiparous women at 4-6 weeks after birth and found that the change in their daily life(amount of enough time in daily life) had a direct effect on role strain(Lisrel Estimates = $-.320$). Bee, Hammond, Eyres, Barnard & Snyder (1986) investigated the effect of parental life change with 193 primiparous mothers. For the sample as a whole, significant negative correlations were obtained between maternal life change in the first year of the child's life and interaction with a 12 month old baby.

Baby's Temperament : Newton(1983) explained a vicious cycle. If, when the infant cries, the parent feels strain in trying to comfort it, the infant senses the parent's feeling state, and so the baby's cries intensify and the parent feels more strain. Wohn(1990) reported that infant temperament and maternal role strain showed a significant relationship ($r = -.13, p < .05$). Lee(1992) found that the more a mother thought her baby's temperament was easy-going, the less maternal role strain she experienced (Lisrel Estimates = $.378$). The results of Wohn's (1990) and Lee's(1992) study were consistent with the findings of Russel(1974). Roberts(1983) investigated 64 primiparous women at 4 weeks after birth and found that infant temperament and maternal role strain showed a significant correlation ($r = -.32, p < .004$) and that the amount of obligatory infant behavior(behavior that required action on the part of the parents) has an effect on parental perceptions of role competence($r = -.27, p < .014$). Roosa, Fitzgerald & Carlson(1982) investigated 62 mothers who had a 3-month old baby and found a significant relationship between infant tempera-

ment and maternal behavior (Lisrel estimate = 8.001). Wilkie and Ames (1986) interviewed 30 mothers with firstborn 6-week-old infants and found that the amount of infant crying was not related to the amount of infant care, that mothers' judgements of feeling negatively about their baby's crying were positively correlated with the amount that their baby cried ($r = .44, p < .05$), and that the depression scale scores of mothers also correlated with the amount of infant crying ($r = .40, p < .05$). Even though, infant crying was correlated with lower evaluation of baby, when the baby cried more, mothers viewed themselves higher as a mother ($r = .34, p < .05$). The reason was that if the baby cried, the mothers seemed to localize the problem in the baby, invested more of themselves in the mother, and felt that they were coping as well as could be expected with this difficulty. This may have been what made them less likely to report inadequacy than did mothers of babies who cried less.

Social Support: Cutrona and Troutman (1986) reported maternal depression did not have a significant correlation with social support, but the mothers who received a high degree of social support, had low stress at 3 months after delivery. Stemp, Turner & Noh (1986) examined changes in the psychological distress of 280 new mothers over a one-year period. The results showed the cognitive experience of social support and the degree of psychological support from the husband made significantly independent contributions to changes in psychological distress.

Durrett, Richards, Otaki, Pennebaker & Nyquist (1986) examined 30 American and Japanese mothers who had a 3-4 month old baby and found that mothers who perceived more support from their husbands, positioned the child more ($r = .32, p < .003$), gave the child more kisses ($r = .21, p < .05$). However, when the mother perceived more support from husband, she spent less total time in the presence of the baby ($r = -.30, p < .007$). Storey (1984) reported that social support and maternal role attainment did not show a significant relationship, but

mothers who received more social support from others, showed a more positive attitude about maternal role attainment.

These findings supported the views expressed by Gibaud-Wallston (1977) and Ruff (1987), who found that ratings of the mother's perception of support from her husband are related to ratings of maternal behavior. The findings of these studies indicated that the more a mother perceived support from her husband, the more apt she was to become involved with the infant when they were together, and the less she felt that she needed to be in the presence of the infant at all times. Also, the adequacy of mothering was influenced by the context of family relationships, and more specifically, by the mother's perception of support from her husband (Mercer, 1986; Lee, 1992).

Hypothesized Model for Testing Hypotheses

The findings of these literature review were combined to form a hypothesized model (fig. 1). This model hypothesizes that change in daily life (CD), baby's temperament (BT), and social support (SS), each affect role strain (RS) and maternal role attainment (MA) and that role strain also influences maternal role attainment.

Methods

Subjects

Subjects were selected from among postnatal women who were in good health. Pregnancy and delivery was without major complication, and a first-born healthy infant was 4 months old to achieve the required time of measurement. This time measurement was based on Mercer (1986) who said that four months following birth is a turning point of adaptation in mothering. Almost two-thirds of the women studied by Mercer reporting that they were comfortable with the maternal role at this time and felt it had become

internalized as part of their identity.

The subjects were recruited primarily through 5 Community Health Centers in Taejon, Korea. When the subjects were asked to participate in this study, most women agreed. Those who refused to participate explained that they were too busy or that it would be bothersome to them, or that they had plans to move to another place.

Questionnaires were mailed to about 250 mothers with a 4 months baby who consented by telephone to participate in the study. Data were collected from 161 mothers(64.4%). The mothers ranged in age from 19 to 34 years, with a mean age of 26.7 years. All primiparous women were married and responded that they came from lower or middle-class families. There were 79(49.1 %) male babies and 82(50.9%) female babies. The level of education completed by the mothers included 49 baccalaureate degrees, 1 graduate degree, 101 high school, 8 middle school, and 2 elementary school. 28 mothers in the sample were employed outside the home. 65 mothers breastfed their infants, 74 mothers bottlefed, and 22 mothers used mixed feeding.

Measures

Maternal role attainment was operationalized by three measures : (1) maternal identity(Semantic Differential Scale-Myself as Mother ; Osgood, et al, 1957), (2) parenting sense of competence(Parenting Sense of Competence Scale ; Gibaud-Wallston, 1977), and (3) perception of mother-infant interaction.

- (1) Maternal identity was assessed by a Semantic Differential Scale, Myself as Mother(SD-Self). The SD-Self consists of 12 bipolar adjective pairs embedded within a 24-item, 5-point semantic differential scale. High scores indicate positive maternal self-evaluations. Cronbach alpha reliability with the sample reported here were .85.
- (2) The parenting sense of competence was assessed by the Parenting Sense of Competence

Scale(Gibaud-Wallston, 1977). Only the 12 item subscale was used in the current study(the additional 5 items were not viewed as conceptually relevant). The items were scored from 1 to 5 with the highest number representing the greatest perceptions of maternal ability. The alpha reliability coefficient was .85.

- (3) Perception of how mother-infant interaction was developed was based upon Barnard's scale (1986). The questionnaire was changed from observing mother-infant interactions to asking subjective perceptions of the mother when the mother interacts with her infant. The questionnaire was assessed using a 13-item index reflecting the degree of mother-infant interaction during care taking activity. The items were scored from 1 to 4 with the higher score indicating the more interaction between mother and child. The alpha reliability coefficient was .78.

Role strain was measured using a 20-item index from Lee's(1984) Korean modification of the Hobbs' Scale(1965). The items were scored from 1 to 4 with the highest number representing the greatest sense of comfort. The alpha reliability coefficient was .83.

Change in daily life was measured by the slightly modified Lee's scale(1984). The only 11-items were used in the current study(The additional 11 items assess financial change, sexual change, change of health status,). The items were scored from 1 to 3, the higher the score, the more time the mothers had to meet their own needs when compared to their experience before delivery. The alpha reliability was .69.

Perception of social support was operationalized by three measures : (1) emotional support from her husband ; (2) physical support from her husband ; and support from others. The mother's perception of emotional support received from her husband was measured using an 8-item index, slightly modified from the Taylor Inventory(Taylor, 1974). The items were scored from 1 to 4 and each item was scored so that the total score reflected the degree of perceived support. The alpha reliability coefficient

was .85. The mother's perception of physical support from her husband(15-items) and the mother's perception of social support from others(12-items) were developed for this study. The items were scored from 1 to 4 with the highest number representing the greatest perception of help from her husband or others. The alpha reliability coefficients were .89 and .80.

To assess mothers' perceptions of their baby's temperamental difficulty, a 12-item index was administered. This tool was developed based upon the Degree of Bother Inventory(Broussard and Hartner, cited in Mercer, 1986). Each item is rated by the mother on a 4-point scale describing the frequency with which the behavior is exhibited by her child. The alpha reliability coefficient was .69.

Data Analysis

Data analysis using the LISREL 5 (Jöreskog and Sörbom, 1988) program was conducted to examine the fit between the hypothesized model and the data.

Results

1. The Identification Status of the Model

There are 15 theoretical parameters and 12 unknown (free) theoretical parameters in the structural model. Also, there are 45 parameters and 23 unknown(free) parameters in the whole hypothetical model. Accordingly, the condition for identification of the model is fulfilled.

2. Sample Size

In this study, there are 161 samples and 23 free parameters-to-be estimated. Since sample size in this study is larger than 115(a ratio of 5 : 1 between the sample size and the number of free parameters-to-be estimated), it is concluded that sample size is appropriate for the solution.

3. Test of the Hypothesized Model

(1) Model / Data fit

To test whether the hypothetical model fits the actual matrices that were empirically obtained from the data, the measures of overall fit were calculated. Table 1 show the findings for application of LISREL to the empirical data and the hypothetical model of Figure 1.

In this study, LISREL calculated the chi-square to be 26.20 with 22 degrees of freedom. The probability was .243. Hence, there appears to be congruence between the hypothesized model and the data. The model presented in Figure 1 yielded overall fits of GFI=.964, AGFI=.927, RMSR=1.904, NNFI=.8221, and NFI=.9056, for the data. There again appears to be a match between the hypothesized model and the data in this study, indicating a good fit.

The largest standardized residual is 3.03 in this data. This is a problem that, in the future, may require theoretical attention and model revision.

The resulting output file of the Q-plot showed that the slope is almost one, so there is a conclusion that this is a good fit(Lee, 1990). The modification index for(4,2) of LAMDA X was 6.37. This means that(4,2) of LAMDA X will be identified if it is set free. However the model that(4,2) of LAMDA X will be set free does not make sense, so(4,2) of Theta Delta only is set free.

(2) Parameter Estimates in the Measurement Model and the Structural Model

There were no estimates below .674 in Table 1. This indicates that the measurement model is very good. The estimate of total coefficient of determination for X and for Y were remarkably high, .999 and .999, indicating that the measurement model is very good. But SMC for emotional support from husband, physical support from husband, and mother-infant interaction were very low.

Change in daily life($\gamma_{11} = -.868$, $T = -3.808$), baby's temperament($\gamma_{12} = -.387$, $T = -2.811$), and

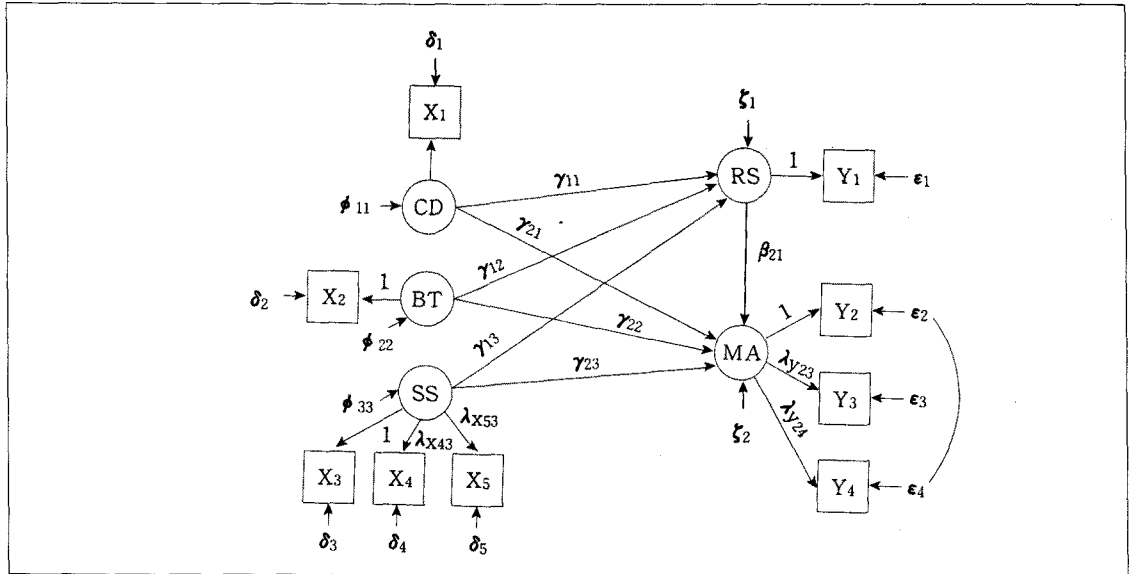

Fig. 1. The Hypothesized Model of Maternal Role Attainment

Table 1. Parameter Estimates and SMC in Measurement Model

Parameter	Estimate	SMC
Change in daily life(CD)	1.000	.967
Baby's temperament(BT)	1.000	.987
Social support(SS)		
λ ₃₃	1.000	.156
λ ₄₃	1.602	.122
λ ₅₃	2.281	.545
Role strain(RS)	1.000	.998
Maternal role attainment(MA)		
λ ₁₂	1.000	.523
λ ₂₂	1.032	.333
λ ₃₂	.674	.278

Note. Estimates are based on the analysis of the covariance matrices

social support ($\gamma_{13} = -2.605$, $T = -3.313$) significantly predicted role strain (Table 2). Role strain was explained 34.1% by change in daily life, the baby's temperament and social support. Maternal role attainment was a powerful endogenous variable explaining 75.5% of the variance among its relationships. But baby's temperament and role strain did not predict maternal role attainment. The change in daily life ($\gamma_{21} = .257$, $T = 2.377$) and social

support ($\gamma_{23} = 1.745$, $T = 3.126$) contributed to the prediction of maternal role attainment (Table 2).

The estimate of the total coefficient of determination in the constructional model was .807. Therefore the constructional model explained 80.7 % of variance in the relationship among the endogenous variables. This means that the predictive variables were well selected.

In summary, based on the results, the high goodness-of-fit index, the noteworthy explained variance of the endogenous variables, and the good empirical support was provided for the study hypothesis and, as such, the theoretical model. But modification of this model was necessary to make the model parsimonious.

4. Modification of the Hypothesized Model

To make the model parsimonious and to improve its fit, 2 parameters whose T values were lower than 2 were set fix and (4,2) of Theta Delta was set free. Baby's temperament to maternal role attainment and role strain to maternal role attainment were excluded.

Table 2. Standardized Coefficients, T-value, and SMC in Structural Model

parameters	direct coefficient	Indirect coefficient	Total(T-Value) coefficient	SMC
Role strain				.341
γ_{11}	-.868	.000	-.868(-3.808*)	
γ_{12}	-.387	.000	-.387(-2.811*)	
γ_{13}	-2.605	.000	-2.605(-3.313*)	
Maternal role attainment				.755
γ_{21}	.288	-.031	.257(2.377*)	
γ_{22}	.042	-.014	.028(.616)	
γ_{23}	1.837	-.092	1.745(3.126*)	
β_{21}	.035	.000	.035(1.151)	

Note. Estimates are based on the analysis of the covariance matrices

The final measures of overall fit indicated a good fit ($\chi^2(23, N=161)=20.89, p=.588, GFI=.972, AGFI=.944, RMSR=1.786, NFI=0.9247, NNFI=0.8576$). Also parsimony of the model improved from $PFI=.6748$ to $PFI=.7297$. The Q-plot shows that the slope was almost one and modification index decreased from 6.37 to 3.05, but the largest standard residual was 3.041.

All these indexes indicate that this modified model fits very well. Table 3 and Figure 2 summarize the findings of the modified model.

Discussion

The theoretical model in which change in daily life, social support, and baby's temperament were linked directly to maternal role attainment, and indirectly linked through their effects on role strain, proved to account for the data quite adequately.

The fit was further improved when 2 paths (baby's temperament to maternal role attainment, role strain to maternal role attainment) were excluded.

One clear implication of these results was that social support and change in daily life are important dimensions of the mother's experience at 4 months following childbirth. Social support and change in daily life exerted both indirect and direct effects on maternal role attainment.

The results of this study provided further evidence to support the importance of maternal social support to maternal role attainment. This finding offered further support to the results of Bee, et al. (1986), Crnic, Greenberg, Robinson & Ragozin (1984), Gibaud-Wallston(1977), and Lee(1992) that women, who reported high levels of social support during performing maternal role, subsequently reported higher levels of self-confidence in the parenting role. Also, this data showed that social

Table 3. Standardized Coefficients, T-value, and SMC in Modified Model

parameters	direct coefficient	Indirect coefficient	Total(T-Value) coefficient	SMC
Role strain				.318
γ_{11}	-.881	.000	-.881(-3.839*)	
γ_{12}	-.369	.000	-.369(-2.734*)	
γ_{13}	-2.470	.000	-2.470(-3.553*)	
Maternal role attainment				.596
γ_{21}	.262	.000	.262(2.481*)	
γ_{23}	1.674	.000	1.674(3.829*)	

Note. Estimates are based on the analysis of the covariance matrices

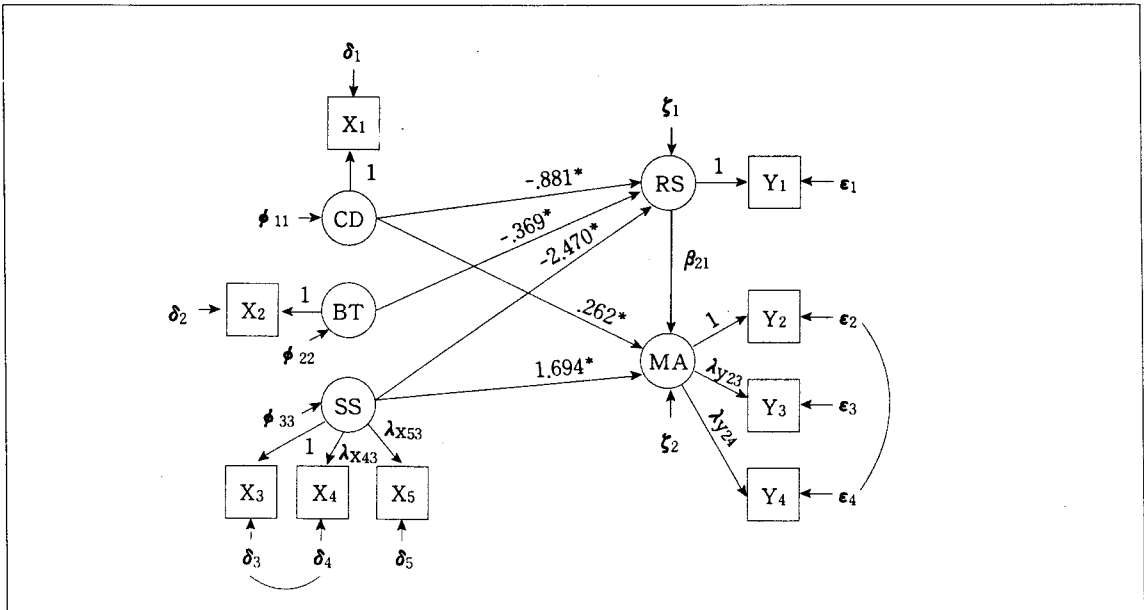

Fig. 2. The Modified Model of Maternal Role Attainment

support influenced role strain. These results supported the results of Lee(1992) that social support directly influenced role strain during the postpartum period and could be helpful in easing the difficulties of the transition period. But the current results did not provide evidence that social support appears to exert its effect on maternal role attainment through the mediation of role strain. Only women who had other people on whom they could rely for a variety of social provisions felt less role strain and, consequently had more confidence in their ability to perform well as mothers. The literature review suggested that emotional support from a mate appeared most important in the transition to the mothering role(Crawford, 1985 ; Lee,1992 ; Mercer, 1986). But the current results indicated that support from others and physical support from husbands from among the three indices of social support accounted significantly for the variance in social support. These results can be explained by the fact that most mothers understand well about infant's temperament at 4 months after birth, so the type of support that mothers needed was to get physical help from their husband and others. Mercer

(1986) reported that the most frequently described type of help mothers need was physical help at 4 months following birth.

Just as social support was shown to be a significant factor on role strain and maternal role attainment, the change in daily life was shown to be a critical factor on role strain and maternal role attainment. Although, Lee(1992) reported that the change in daily life did not effect maternal role attainment with 224 primiparas at 4-6 weeks after birth, the change in daily life effected maternal role attainment at 4 months postbirth in the current study. This result means that the more the infant grow up, the more the infant ask much to the mother than before. So, the mothers felt that they do not have enough time left over to meet their own needs. Mercer(1986) reported that most primiparas felt that they lacked sufficient time to meet all their responsibilities. The effect of change in daily life on role strain supported the results of Lee(1992) and of Roberts(1983) that the amount of normative change was related to role strain. Bee et al.(1986) suggested that parental life changes have an impact on mother's behavior and Burr et al.(1979) proposed

that the greater the normative change, the less the ease in making the role transition.

The parameter estimates for the structural equation model revealed that the relationship between baby's temperament and maternal role attainment was weak and nonsignificant ($\gamma_{22} = .028$, $T = .616$). So the link from baby's temperament to maternal role attainment was excluded. Baby's temperament directly influenced role strain, but it did not influence maternal role attainment indirectly through the perceived role strain. The relationships between baby's temperament and role strain supported the results of Roberts(1983), Lee(1992), Russel(1974) and Wohn(1990) that infant's temperament was significant for role strain. Research has shown that infant's temperament influenced maternal role attainment (Cutrona and Troutman, 1986 ; Gibaud-Wallston, 1977 ; Roosa et al., 1982). This study, however, showed that baby's temperament did not influence maternal role attainment. It can be explained that even though a mother may feel that her baby's temperament is very difficult, and she may feel resentful and disappointed that her infant is unlike the child she had envisioned during pregnancy, this difficulty did not have a significant negative effect on maternal role attainment. Also, these results may indicate that most mothers accepted a temperamentally difficult infant as a matter of course and they accepted an inevitable duty. Or, the operationalization of baby's temperament was problematic. Only one measurement indicator measured baby's temperament. Therefore, it cannot be accurately measured by only one single measure.

Baby's temperament, change in daily life, and social support significantly influenced role strain. So, to reduce role strain, mother must receive as much support as she needs and the environment can be afford as much as the mother has her own room and own time.

But, only 31.5% of the variance in role strain was explained by these 3 variables (baby's temperament, change in daily life, and social support). So, other variables, not measured in this study, will be con-

sidered in the future study. Also role strain was measured by only one indicator using Hobbs' scale (1965). Wohn(1990) has done factor analysis on this scale, but it may not be a valid measure of role strain. Her research is somewhat limited due to convenience sampling.

Role strain construct needs to be refined thoroughly in the future work. Role strain did not influence maternal role attainment. Almost two-thirds of the women studied by Mercer(1986) reporting that they were comfortable with the maternal role at the 4 months after birth and felt it had become internalized as part of their identity. Like Mercer's report, even most mothers felt role strain, the role strain did not influence maternal role attainment in this study. The other reason that the weak, nonsignificant relationship between role strain and maternal role attainment construct may be related to the conceptualization and/or the operationalization of role strain and maternal role attainment. Since maternal identity, parenting sense of competence, and perception of mother-child interaction were combined to indicate the concept of maternal role attainment, it is probable, and theoretically quite likely, that the concept of maternal role attainment is more complex than sum of its parts. Therefore, it cannot be accurately measured by combining only three measurement scores. If this is the case, then a new instrument needs to be developed which accurately measures the integral nature of maternal role attainment. In the future, this integral aspect of maternal role attainment needs further theoretical and operational attention.

Nursing Implications

The model tested here suggests three primary avenues for intervention : (1) increasing the amount of enough time in daily life , (2) increasing perceived social support, and (3) knowing the baby's temperament well. So, nurses who work with mothers and infants need to be aware that these 3 variables may

have a more consistent influence on role strain and role attainment. Nurses should try to include fathers in the birth-preparation classes or mother's classes so fathers can learn about the importance of fathers, receive instruction on child development and child care, and discuss the value of their postnatal involvement in the home. After a baby is delivered, nurses must create an environment of greater communication between the mother and the father as they assess their current child care activity and discuss the need for shared child care. The mother should be encouraged to use delegation of tasks for reducing maternal role strain. Nurses should try to increase the father's involvement in child care and housework, thereby allowing mothers to have time for themselves and decrease maternal role strain.

REFERENCES

- Bee, H. L., Hammond, M. A., Eyres, S. J., Barnard, K. E., & Snyder, S. J. (1986). The impact of parental life change on the early development of children. Research in Nursing & Health, 9, 65-74.
- Bobak, I. M., Jensen, M. D., & Zalar, M. K. (1989). Maternity and Gynecologic Care. (4th ed.) The C. V. Mosby Co.
- Burr, W. R., Holl, R., Nye, F. I., & Reiss, I. C. (1979). Contemporary theories about the family, Vols.1 & 2. N. Y.: Freepress.
- Crawford, G. (1985). A theoretical model of support network conflict experienced by new mothers. Nursing Research, 34(2), 100-102.
- Crnicek, K. A., Greenberg, M. T., Robinson, N. M., & Ragozin, A. S. (1984). Maternal stress and social support: Effects on the mother-infant relationship from birth to eighteen months. Amer. J. Orthopsychiatrics., 54(2), 224-235.
- Cutrona, C. E., & Troutman, B. R. (1986). Social support, infant temperament, and parenting self-efficacy. A mediational model of postpartum depression. Child Development, 57, 1507-1518.
- Durrett, M. E., Richards, P., & Otaki, M., Pennebaker, J. W., & Nyquist, L. (1986). Mother's involvement with infant and her perception of spousal support, Japan and America. Journal of Marriage & Family, 48, 187-194.
- Gibaud-Wallston, J. (1977). Self-esteem and situational stress: Factors related to sense of competence in new parents. University Microfilms International, Ann Arbor, Michigan, 48106.
- Hobbs, D. F. (1965). Parenthood as crisis. Journal of Marriage and the Family, 27, 367-372.
- Jöreskog, K. G., & Sörbom, D. (1988). Lisrel 7: A Guide to the Program and Applications, Chicago: SPSS Inc.
- Lee, H. K. (1992). Construction of a maternal role attainment model in primiparas during the postpartum period. Doctoral dissertation, Seoul National University.
- Lee, J. S. (1984). A study on family life change perceived by husband and wife after first born. Master thesis, Korea University.
- Lee, S. M. (1990). Covariance structure analysis. Sungwon Press.
- Majewski, J. L. (1985). Conflict, satisfactions, and attitudes during transition to the maternal role., Nursing Research, 35(1), 10-14.
- Mercer, R. T. (1986). First-Time Motherhood. Experiences from Teens to Forties. New York, Springer Publishing Co.
- Newton, L. D. (1983). Helping parents cope with infant crying. JOGNN, May/June, 199-204.
- Osgood, C. E., Suci, G. J., & Tannenbaum, P. H. (1957). The measurement of meaning. Urbana, IL: University of Illinois Press.
- Roberts, F. B. (1983). Infant behavior and the transition to parenthood. Nursing Research, 32(4), 213-217.
- Roosa, M. W., Fitzgerald, H. E., & Carlson, N. A. (1982). A comparison of teenage and older mothers: A systems analysis. Journal of marriage and the family, May, 367-377.
- Rubin, R. (1967). Attainment of the Maternal Role:

Part 1, Processes. Nursing Research, 16, 237-245.

- Ruff, C. C. (1987). How well do Adolescents Mother? MCN, 12, July/Aug, 249-253.
- Russel, C. S. (1974). Transition to parenthood. problems and gratification. Journal of Marriage and the Family, 36, 294-302.
- Storey, M. (1984). An analysis of factor influencing maternal role acqusion in mothers of handicapped children, focusing on a comparison with mothers of non-handicapped children. Doctoral dissertation, Yonsei University.
- Stemp, P. S., Turner, R. J., & Noh, Samuel (1986). Psychological distress in the postpartum period. The significance of Social Support. Journal of Marriage & Family, 48(May), 271-277.
- Taylor, J. (1974). Systometrics. Unpublished manuscript, University of Pittsburgh.
- Walker, L. O., Crain, H., & Thompson, E. (1986a). Maternal role attainment and identity in the postpartum period. Stability and change. Nursing Research, 35(2), 68-71.
- Walker, L. O., Crain, H., & Thompson, E. (1986b). Mothering behavior and maternal role attainment during the postpartum period. Nursing Research, 35(6), 352-355.
- Wilkie, C. F., & Ames, E. W. (1986). The relationship of infant crying to parental stess in the transition to parenthood. Journal of Marriage & Family, 48 (August), 545-550.
- Wohn, J. S. (1990). An empirical study on transition to parenthood. Master thesis, Ewha Womans University.

-국문초록-

구조모형을 이용한 모성역할 획득 이해 (대전에 사는 어머니를 대상으로)

이 혜 경*

모성역할 획득에 영향을 주는 변수를 이해한다는 것은 모성역할 획득에 대한 체계적인 연구와 실질적인 간호중재를 가능하게 한다. 생후 4개월된 첫 아기가 있는 어머니를 대상으로 모성역할 획득모형을 발전시키려고 이 연구를 시도하였다. 가설적 모형은 5개의 변수(모성역할 획득, 모성역할 긴장, 일상생활의 시간적 여유, 아기 기질, 사회적지지)로 구성되었다. 대전시에 거주하는 대상자에게 전화를 통하여 동의를 얻은 후, 우편으로 250명에게 질문지를 보내어 161명(64.4%)으로부터 회수되었다. 자료를 Lisrel 프로그램을 이용하여 공변량구조분석을 한 결과, 자료와 가설적 모형과의 전반적 지수는 자유도 21에 카이자승치 31.47, GFI와 AGFI의 값은 .970, .935였고, RMSR, NFI, NNFI는 각각 1.668, .9097, .9425이었다. 간명하고 부합도가 더 좋은 모형을 찾기 위하여 통계적 결과와 이론적 적합성에 따라 2경로(아기 기질에서 모성역할 획득, 모성역할 긴장에서 모성역할 획득)를 고정시켰다. 수정모형의 PFI(간명도)가 .7297로 증가하여 수정모형이 더 간명하면서도 부합도가 좋은 모형으로 나타났다.

공변량구조분석 결과 나타난 변인간의 관계는 일상생활의 시간적 여유가 많을 수록, 사회적 지지를 많이 받을 수록, 아기 기질이 순하다고 생각할수록 모성역할 긴장은 적었고, 일상생활의 시간적 여유가 많을 수록, 사회적 지지를 많이 받을수록 모성역할 획득은 잘 되었다.

* 강원대학교 의과대학 간호학과