

work.

**Acknowledgement.** This work was financially supported by the grant (3-1-3, 1986) from the Korea Research Foundation.

### References

1. A. Silberberg, *J. Chem. Phys.*, **48**, 2835 (1968).
2. C. A. J. Hoeve, *J. Polym. Sci. C*, **30**, 361 (1970).
3. S. G. Ash, D. H. Everett, and G. H. Findenegg, *Trans. Faraday Soc.*, **66**, 708 (1970).
4. R. -J. Roe, *J. Chem. Phys.*, **60**, 4192 (1974).
5. E. Helfand, *J. Chem. Phys.*, **63**, 2192 (1975); *Macromolecules*, **9**, 307 (1976).
6. J. M. H. M. Scheutjens and G. J. Fleer, *J. Phys. Chem.*, **83**, 1619 (1979).
7. W. Lee and H. Pak, *Bull. Korean Chem. Soc.*, **8**, 19 (1987).
8. A. Halperin and P. Pincus, *Macromolecules*, **19**, 79 (1986).
9. J. S. Rowlinson and B. Widom, *Molecular Theory of Capillarity*, Oxford University Press, Oxford, 1982.
10. J. W. Cahn and J. E. Hilliard, *J. Chem. Phys.*, **28**, 258 (1958).
11. P. -G. de Gennes, *Scaling Concepts in Polymer Physics*, Cornell University Press, Ithaca, NY, 1979.
12. P. -G. de Gennes, *Macromolecules*, **14**, 1637 (1981).
13. P. J. Flory, *J. Chem. Phys.*, **10**, 51 (1942).
14. P. J. Flory, *Principles of Polymer Chemistry*, Cornell University Press, Ithaca, NY, 1953.

## Construction of a Dynamic Laser Light Scattering System Using a Personal Computer†

Myung Joong Kim\*, Sang Yong Lee, Koo-Soon Chung, and Hoosung Lee

Department of Chemistry, Sogang University, Seoul 121. Received March 30, 1987

A dynamic laser light scattering system has been constructed using a personal computer. The intensity of the scattered light was detected with a photomultiplier tube and a photon counter. The BCD output of the photon counter which is proportional to the intensity of scattered light is fed into a personal computer via an interface card. The personal computer was programmed as an autocorrelator in machine language. The data acquisition rate of the system was about 600 samples/s which is adequate for studies on the molecular dynamics of concentrated polymer solutions, polymer lattices with large particle size, and polymer glass systems. The constructed system was tested with polystyrene latex and the measured diameter of the latex particle agrees well with the supplier's value.

### Introduction

Dynamic laser light scattering techniques are now among the most frequently adopted techniques in the study of molecular dynamics in polymer solutions and melts.<sup>1-8</sup> Especially, the photon-counting spectroscopy (PCS) has made it possible to study the chain dynamics in polymer melts<sup>4,5,8</sup> for which the ordinary spectrum analysis technique suffers difficulties due to the extremely low intensities of the scattered light. The most expensive part of a commercial laser light scattering system with a digital autocorrelation capability is the digital autocorrelator. However, if a personal computer can be used in place of an autocorrelator, such a light scattering system can be constructed at a very low cost. The object of this work was to construct a low cost laser light scattering system with such a capability and with a decent data acquisition rate, then to use the instrument in researches on molecular dynamics of polymers.

† On the occasion of sixtieth birthday of Professor Nung Min Yoon to honor his distinguished work and devotion in organic chemistry and education.

\* Present address: Polymer Department, Lucky Central Research Institute, Science Town, Dae Jeon 300.

### Experimental

The block diagram of the overall system is shown in Figure 1. A 1.5 mW He/Ne laser (Spectra Physics, 196-1) was used as a light source. A cylindrical Pyrex vial (25 mm in diameter) was used as a sample cell, which was placed in a thermostatted brass sample holder. A photomultiplier tube (PMT, Hamamatsu, R464) in conjunction with a photon-counter (Hamamatsu, C1230) was used to detect the scattered photons. The photon-counter includes several built-in units such as a preamplifier, a discriminator, a pulse counter, and a high voltage power supply for the PMT. The PMT gives current pulses at a rate which is proportional to the intensity of the scattered light. The current pulses are amplified and discriminated by the preamplifier and the discriminator, respectively. The pulse counter counts the photon pulses from the discriminator for a given time increment and the result is available as the output in binary coded decimal (BCD) format. The BCD output of the photon-counter is read, via an interface card, into a personal computer, Apple II+ compatible. An ADALAB™ Interface Card (Interactive Microwave, Inc.) was utilized to interface the computer with the photon counter. The circuit diagram and the program-

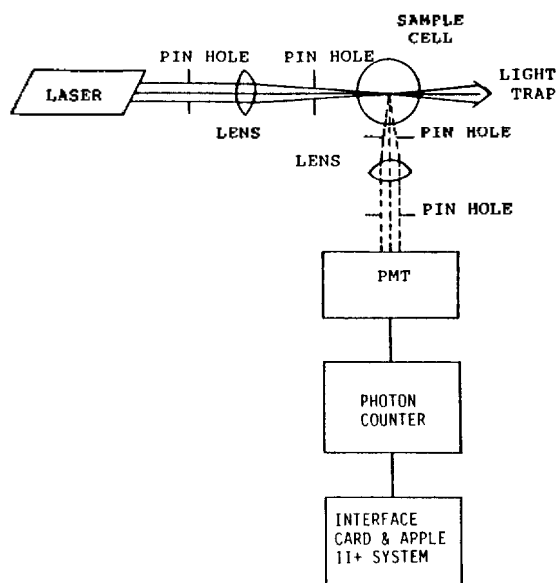

Figure 1. Schematic diagram of the light scattering instrument.

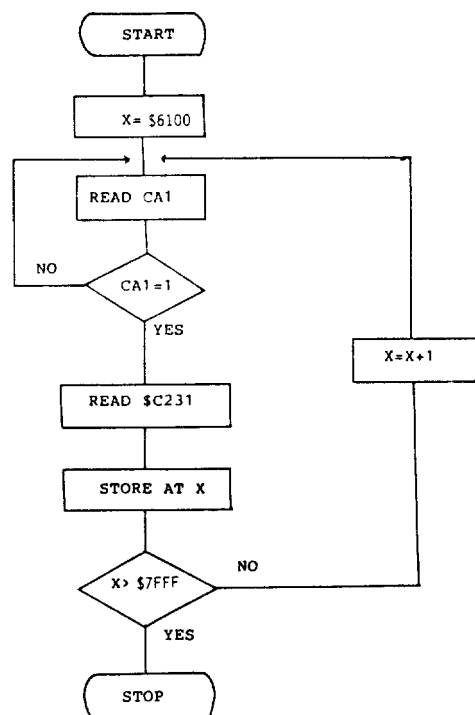

Figure 2. The flow chart for the data acquisition routine.

ing considerations for the ADALAB card are available in the instruction manual.<sup>9</sup> The ADALAB card has a 6522 versatile interface adaptor (VIA) chip which has two digital I/O ports, a programmable timer, and a counter. One of the digital ports is programmed to read the photon counter output. The timer function of the VIA is used to generate timing pulses to trigger the photon counter, *i.e.* "start" and "stop" signals for the counter. Since the output of the photon counter is binary coded decimal (BCD), it was necessary to convert the acquired data into binary prior to the computation of the correlation function.

Acquired data are first stored in the computer memory, then manipulated to obtain the correlation function. This se-

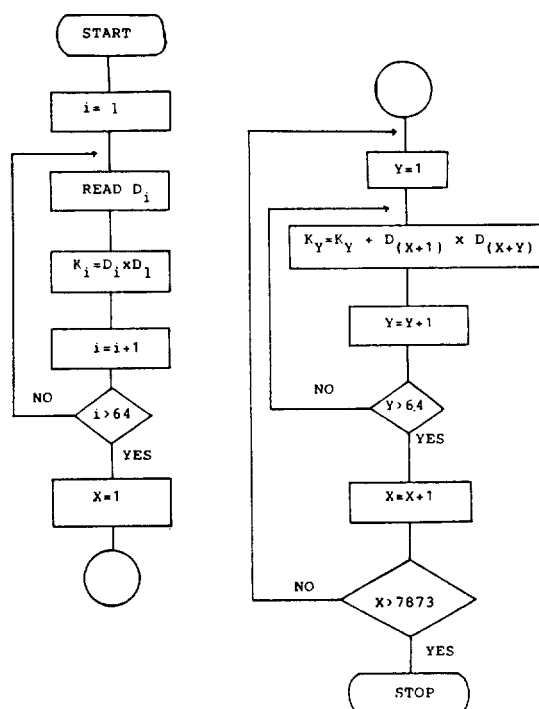

Figure 3. The flow chart for the autocorrelation routine.

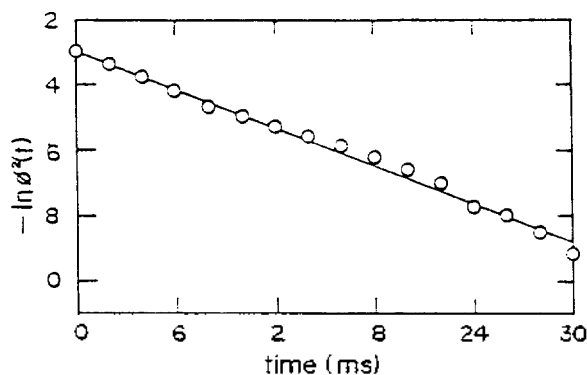

Figure 4. Plot of  $-\ln \phi^2(t)$  vs. time for the polystyrene latex system. The scattering angle was  $36^\circ$ , the temperature was 293 K, and the latex was dispersed in glycerol/water (25/75 by volume) mixture.

quence is necessary in order to maximize the acquisition rate, especially for the system in which the molecular motions are fast.<sup>1,2</sup> The flow chart for the data acquisition routine is shown in Figure 2. The digital I/O port address of the ADALAB card is \$C231 in hexadecimal.<sup>9</sup> The symbol CA1 indicates the flag register, *i.e.* when the register is high (= 1), the datum is ready for reading. Then the computer reads the input value from \$C231 and resets the flag. The received datum is then stored sequentially in the RAM (random access memory) from \$6100 to \$7FFF (8k). When the RAM is filled up to \$7FFF, the computer starts converting the stored data from the BCD to binary.

Upon completing the conversion, the computer starts computing the autocorrelation. The flow chart for the autocorrelation routine is shown in Figure 3. The programs for the data-acquisition and auto-correlation function were written in the machine language, which are listed elsewhere.<sup>10</sup> It took about 7 minutes for the calculation of the autocorrela-

**Table 1. The diameter of the Latex Particles Compared with the Supplier's Value**

D (cm <sup>2</sup> /s)	d(um)	
	measured	supplier's value
$(1.3 \pm 0.3) \times 10^{-9}$	$1.3 \pm 0.3$	$1.05 \pm 0.07$

tion function.

For the purpose of testing the system, light scattering experiment was performed on a polystyrene latex dispersion with a known particle size. The concentration of the latex was 25 μg/ml. The latex system was prepared by diluting the as received latex system (Polyscience, Cat. #7310, diameter = 1.05 ± 0.07 μm) in glycerol solution (approximately 25% in water). This was necessary to slow down the diffusional motions of the latex particles, so that the correlation function can be recorded with a reasonable accuracy within the time window of the correlator. The viscosity of the dispersing medium turned out to be 0.0230 poise at the experimental temperature, 293 K. The scattering angle was 36° and the refractive index of the dispersing medium was 1.37.

### Results and Discussion

The performance of the system is demonstrated in Figure 4 by the relaxation function of the latex system. The normalized homodyne auto-correlation function C(t) is related to the relaxation function C(t) by the following relationship<sup>1,2,8</sup>:

$$C(t) = 1 + \phi^2(t) \quad (1)$$

The relaxation function obtained for the latex is plotted in a semi-logarithmic scale in Figure 4. For an ideal system like a latex of a uniform particle size, the relaxation function is related to the diffusion coefficient D by the following equations<sup>1,2</sup>:

$$\phi(t) = A \exp(-t/\tau) \quad (2)$$

$$\tau = 1/(K^2 D) \quad (3)$$

$$K = 4\pi(n/\lambda) \sin(\theta/2) \quad (4)$$

where  $\tau$  is the relaxation time, A is a factor determined by the scattering geometry, K is the scattering vector, n is the refractive index of the solvent,  $\lambda$  is the wavelength of the light, and  $\theta$  is the scattering angle. From the slope of the straight line in Figure 4 and by means of equations (2), (3), and (4), one can calculate the diffusion coefficient of latex particles. Furthermore, the hydrodynamic diameter d of latex particles can be calculated by means of the Stokes-Einstein equation,<sup>1,2</sup>

$$D = \frac{kT}{3\pi\eta d} \quad (5)$$

where k is the Boltzman's constant, T is the temperature, and  $\eta$  is the viscosity of the dispersing medium. The diffusion coefficient and the diameter of latex particles measured by the constructed system are listed in Table 1 along with the supplier's value.

Presently, the major source of errors in the determination of the particle size is the uncertainty in the measurement of the scattering angle. Because the current system is not equipped with any optical rotary table yet, the measurement of the scattering angle produces an error of approximately ± 4°. At the scattering angle of 36°, this corresponds to an error of about ± 25 % in the diameter, as well as in the diffusion coefficient, of the latex particles. Considering this, the measured diameter of the latex particles using the constructed system agrees well with the supplier's value within the experimental error.

The data acquisition rate of the laser light scattering system is about 600 samples/s which is not limited by the computer, but by the photon counter. Such an acquisition rate may not be high enough for the study of molecular dynamics in dilute polymer solutions. But it is fast enough for the study of concentrated polymer solutions, lattices of large particle size, and polymer glasses.<sup>4,5,8</sup> The only drawback of the present system is the low data rate and the low accuracy in the measurement of the scattering angle. It is expected that the data rate can be enhanced by about 50 times by modifying the photon counter circuit, which is now in progress. Attachment of an optical rotary table is now underway.

Another important feature of the system is that it can be constructed easily, at less than U.S.\$3,000 including the optical parts.

**Acknowledgement.** This research was supported in part by the Korea Science and Engineering Foundation. The authors are grateful to Dr. Chong-Hong Pyun, Korea Advanced Institute of Science and Technology for helpful discussions and advice, especially on the interfacing problems.

### References

1. B. Chu, "Laser Light Scattering", J. Wiley and Sons, Inc., New York, 1976.
2. B. J. Berne and R. Pecora, "Dynamic Light Scattering", J. Wiley and Sons, Inc., New York, 1976.
3. H. Reihanian and A. M. Jamieson, *Macromolecules*, **12**, 684 (1979).
4. H. Lee, A. M. Jamieson, and R. Simha, *Macromolecules*, **12**, 329 (1979).
5. H. Lee, A. M. Jamieson, and R. Simha, *Colloid and Polymer Science*, **258**, 545 (1980).
6. W. Brown and R. Rymden, *Macromolecules*, **19**, 2942 (1986).
7. T. Coviello, K. Kajiwara, B. Burchard, M. Dentini, and V. Crescenzi, *Macromolecules*, **19**, 2826 (1986).
8. G. D. Patterson, C. P. Lindsey and J. R. Stevens, *J. Chem. Phys.*, **70**, 643 (1979).
9. P. K. Warme, "ADALAB Interface Card Instruction Manual", Interactive Microwave, Inc., P.O. Box 139, State College, PA, 1984.
10. M. J. Kim, Thesis for the degree of Master in Science. Sogang University, 1987.