

Development of Air Suction Control System for Continuous Air Contamination Monitor

Jongsoo Kim, Sung-Ho Lee, O-Young Kwon, and Hae-Cho Lee

Korea Atomic Energy Research Institute, Daedeok-daero989ben-gil 111, Yuseong-gu, Daejeon, Republic of Korea
jskim4@kaeri.re.kr

1. Introduction

Nuclear facilities generally operate continuous air monitoring systems to monitor contamination by radioactive materials. The air intake position of the air monitoring system is determined in consideration of the working space of the work room, the air flow, and the radiation concentration. In this paper, an air suction control system for covering a relatively wide area is considered.

2. Air Suction Control System

2.1 Hardware Configuration

The ASCS (Air Suction Control System) consists of air suction valves and a controller and is connected to the air monitoring system as shown in Fig 1. The suction valve is opened or closed by the controller. The room air passes through the pipe while the valve is open. The number of valves can be set in consideration of the space or structure of the work room, but four intake valves are considered in this study. This means that air from four zones can be monitored according to a defined schedule. The instantaneous response time of each valve at opening and closing is almost 2.5 seconds. The controller consists of PLC (program control logic), clock timer, valve selection switches, and indicate lamps.

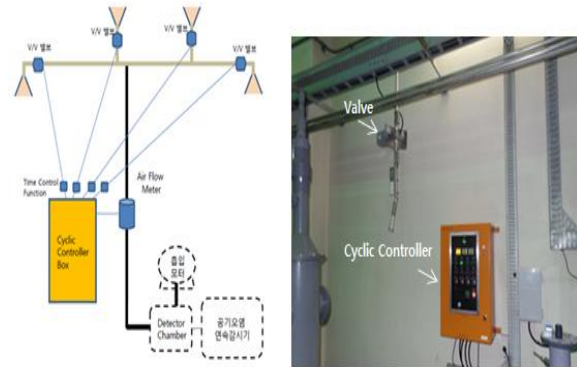

Fig. 1. Configuration of the ASCS.

2.2 Operation mode

The operating mode of the ASCS is normal, interim, and fixed operations, as shown in Fig. 2.

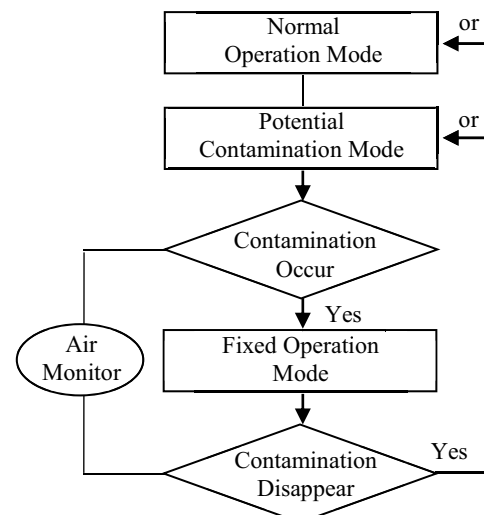

Fig. 2. Sequential operation of the ASCS.

If air contamination is not expected, the normal operating mode can be selected by an operator. In this mode, the air intake through the valve operates sequentially at regular time intervals. However, if air

contamination is anticipated, the valve can be switched to a suspicious position and the air intake will continue to operate until air contamination disappears at its position.

2.3 Error code analysis

If an error occurs while the ASCS is inhaling air, the buzzer and the lamp are designed to occur at the same time. In order to find out the error easily and to recover the error quickly, the error codes were analyzed that may cause the error, which is shown in Table 1. The error could be classified into five groups, each of which could be subdivided into sub-error codes.

Table 1. Analyzed possible error of the ASCS

Error code	Error contents
Telecommunication module error related to hardware	
E00-01	Hardware self- diagnostic error
E00-02	PLC and interface error of the module
E00-03	Power and hardware error of FOU group
E00-04	Initial error of input/output and module in slave group
Telecommunication error of the module	
E01-01	F-net telecommunication error in master and slave group
E01-02	F-net telecommunication error in FOU
PLC and interface error of telecommunication module	
E02-01	PLC and interface error in master and telecommunication module group
E02-02	F-net Input/output module with interface error in slave group
Operation error of high speed link function	
E03-01	High speed link parameter in error status communication tool
E03-02	Fault of high speed link
E03-03	HSxRLNK, HSxTRx electric contact error during high speed link

E03-04	HSxLTRBL electric contact error during high speed link
Operation error of telecommunication command service	
E04-01	Command error of ERR "ON", STATUS "0" in F-net service mode
Operation error of GMWIM	
E05-01	No response message occurrence in remote contact
E05-02	Others error in remote contact

3. Conclusion

Most of air contamination monitoring is used air suction pathway of single channel. In the other side, the ASCS can be applied several air suction channels for the radioactive substance treatment laboratory of a large area. It will more effect than single channel method.

Equipment to be used a nuclear facility should be analyzed for error to recover quickly. In this point of view, the ASCS analyzed the possible errors and proved them through experiments.

REFERENCES

- [1] LG Inc., "Fine Field I/F Module programmable Control Logic Controller", GLOFA-GM MASTER-K
- [2] HSE, "Electric Actuated Ball Valve" Series, 3 PIECE SCRD D-Type