

Development of C-14 Stripping Method From Waste Resin Generated From HWR via Microwave Treatment: Part 2, Demonstration Equipment for C-14 Stripping

Ki Rak Lee^{a*}, Hwan-Seo Park^a, Hyeon-Oh Park^b, Jung-Hoon Choi^a, and Seung-Youb Han^a

^a Pyroprocess Technology Division, Korea Atomic Energy Research Institute (KAERI), 111 Daedeok-daero 989, Yuseong-gu, Daejeon, Republic of Korea

^b Sunkwang T&S Co.,Ltd, Sunkyung Officetel 20F, #3, Gongwon-ro, Guro-gu, Seoul, Republic of Korea

*kirakki@kaeri.re.kr

Inorganic and organic ion exchange materials were generally applied to liquid processes in nuclear reactor. In the case of heavy-water reactor (HWR), zeolite, active carbon, anion resin, and cation resin were used to treat liquid processes such as reactor primary coolant cleanup and liquid radioactive waste management system. Then, used ion exchangers were stored at storage tanks. Various kinds of nuclides were adsorbed in ion exchange materials. Especially, C-14, long half-life nuclide, was highly concentrated in anion resin, and waste resin was treated as intermediated level radioactive waste (ILW).

In KOREA, 4 units of heavy-water reactor are operated and a lot of spent resins are generated. Until now, 580 m³ of waste resins were generated from Wolsung HWR unit 1 and 2 and stored at storage tank (storage tank capacity of Wolsung HWR unit 1 and 2: 986 m³). Enormous cost will be expected to dispose this radioactive waste if there is no process treating this waste.

Conventional process to treat radioactive wastes is not suitable for treating spent resin. To solve this problem, various kinds of processes were developed such as acid stripping, PLO process, activity stripping, thermal treatment, and etc. In this study, new process using microwave, is suggested. Basic characterization of anion and cation surrogate waste resin was conducted. Demonstration equipment was

manufactured using characterization data.

In our previous study, C-14 nuclide was easily desorbed from waste resin via microwave treatment. Then, demonstration equipment using microwave is manufactured in this study. The equipment was composed of a microwave reactor, a condenser, two adsorption tower, and circulation part. Closed loop system was applied to the equipment. Test using surrogate waste resin (mixture of anion and cation) is scheduled and real waste resin will be treated for demonstration.

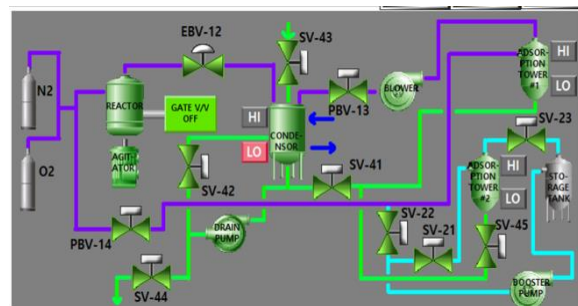

Fig. 1. P&ID of demonstration equipment.



Fig. 2. Image of demonstration equipment.

REFERENCES

- [1] Technical Reports Series no. 408, Application of ion exchange processes for the treatment of radioactive waste and management of spent ion exchangers, IAEA, Vienna, 2002.
- [2] M. Matsuda, K. Funabashi, T. Nishi, H. Yusa, M. Kikuchi, "Decomposition of ion exchange resins by pyrolysis", Nuclear Technology, 75 (1986), 187-192.