

Comparison of Two Reactive Power Definitions in DFIG Wind Power System under Grid Unbalanced Condition

Daesu Han and Yongsug Suh

Dept. of Elec. Eng., Smart Grid Research Center, Chonbuk National University.

ABSTRACT

This paper compares two instantaneous reactive power definitions in DFIG wind turbine with a back-to-back three-level neutral-point clamped voltage source converter under unbalanced grid conditions. In general, conventional definition of instantaneous reactive power is obtained by taking an imaginary component of complex power. The other definition of instantaneous reactive power can be developed based on a set of voltages lagging the grid input voltages by 90 degree. A complex quantity referred as a quadrature complex power is defined. Proposed definition of instantaneous reactive power is derived by taking a real component of quadrature complex power. The characteristics of two instantaneous reactive power definitions are compared using the ripple-free stator active power control algorithm in DFIG. Instantaneous reactive power definition based on quadrature complex power has a simpler current reference calculation control block. Ripple of instantaneous active and reactive power has the same magnitude unlike in conventional definition under grid unbalance. Comparison results of two instantaneous reactive power definitions are verified through simulation.

1. Introduction

Wind power installation has been increasing both in number and size of individual wind turbine unit. Doubly Fed Induction Generator (DFIG) is widely used as wind generator due to its economic requirement of power converter in rotor side. The structure of DFIG wind power system with a back-to-back three-level NPC voltage source converter is described in Fig. 1.

Because of the direct connection between the stator and grid in DFIG wind generator, the unbalanced grid voltage causes unbalanced stator currents. The unbalanced currents generate unequal heating of the stator windings and oscillations of torque and output power resulting in a mechanical stress on the drive train and gearbox as well as adverse acoustic noise [1].

The control methods of the Grid Side Converter (GSC) to eliminate input power oscillations at the grid side of rotor under unbalanced input supply have been investigated in past few years. In [2], Suh and Lipo have proposed a method to directly control the instantaneous active power at the poles of the rectifier. The control method in [2] can achieve effective elimination of the oscillations under unbalanced operating conditions.

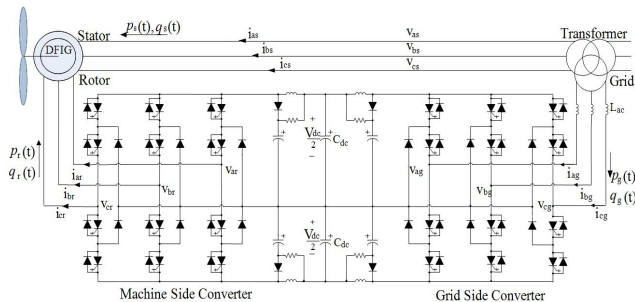

Fig. 1 Overall scheme of DFIG wind turbine with a back-to-back three-level NPC voltage source converter

Control of the Machine Side Converter (MSC) in DFIG wind power system with back-to-back converter to reduce torque pulsation by compensating the rotor current under unbalanced grid voltage has been studied in past few years. Control method to reduce torque pulsation and rotor current harmonics by compensating negative sequence components utilizing either GSC or MSC was developed in [3]. In [4], control methods to eliminate pulsations of torque using MSC and to compensate oscillation of active and reactive power and current of stator were presented.

In this paper, two instantaneous reactive power definitions are compared in DFIG wind turbine with a back-to-back three-level neutral-point clamped voltage source converter under unbalanced grid condition. The one definition of instantaneous reactive power is the conventional method, i.e. the imaginary part of complex power in a space vector. The other definition of instantaneous reactive power is based on quadrature complex power. First, model of DFIG and two instantaneous reactive power definitions are introduced. Second, the comparison of two instantaneous reactive power definitions using the ripple-free stator active power control algorithm in DFIG is presented. Finally, comparison results are verified through simulation result. The effective instantaneous reactive power definition for unbalanced grid condition is proposed and validated in this paper.

2. Dynamic Model and Power Definition of DFIG under Unbalanced Conditions

2.1 DFIG model under unbalanced conditions

Under unbalanced grid voltage, DFIG can be effectively modeled by using both positive and negative sequence components of voltages and currents. Under the assumptions of zero resistive voltage drops and steady-state condition, the positive and negative sequence components for the voltages of stator and rotor in a synchronous rotating frame are expressed as followings.

$$V_{dqs}^p = j\omega L_s I_{dqs}^p + j\omega L_m I_{dqr}^p \quad (1)$$

$$V_{dqs}^n = -j\omega L_s I_{dqs}^n - j\omega L_m I_{dqr}^n \quad (2)$$

2.2 Instantaneous stator output active power

The instantaneous output active power of stator is obtained by taking the real part of the complex power [2].

$$S_s = \frac{3}{2} V_{dqs}^s I_{dqs}^{s*} = \frac{3}{2} (e^{j\omega t} V_{dqs}^p + e^{-j\omega t} V_{dqs}^n) (e^{j\omega t} I_{dqs}^p + e^{-j\omega t} I_{dqs}^n)^* \quad (3)$$

$$p_s(t) = \text{Re}\{S_s\} = P_{so} + P_{sc2} \cos(2\omega t) + P_{ss2} \sin(2\omega t) \quad (4)$$

$$\begin{bmatrix} P_{so} \\ P_{ss2} \\ P_{sc2} \end{bmatrix} = \frac{3}{2} \begin{bmatrix} V_{ds}^p & V_{qs}^p & V_{ds}^n & V_{qs}^n \\ V_{qs}^n & -V_{ds}^n & -V_{qs}^p & V_{ds}^p \\ V_{ds}^n & V_{qs}^n & V_{ds}^p & V_{qs}^p \end{bmatrix} \begin{bmatrix} I_{ds}^p \\ I_{qs}^p \\ I_{ds}^n \\ I_{qs}^n \end{bmatrix} \quad (5)$$

2.3 Conventional definition of instantaneous stator output reactive power

In general, conventional definition of instantaneous stator reactive power is obtained by taking an imaginary component of complex power [4].

$$q_s(t) = \text{Im}\{S_s\} = Q_{so} + Q_{sc2} \cos(2\omega t) + Q_{ss2} \sin(2\omega t) \quad (6)$$

$$\begin{bmatrix} Q_{so} \\ Q_{ss2} \\ Q_{sc2} \end{bmatrix} = \frac{3}{2} \begin{bmatrix} V_{qs}^p & -V_{ds}^p & V_{qs}^n & -V_{ds}^n \\ -V_{ds}^n & -V_{qs}^n & V_{ds}^p & V_{qs}^p \\ V_{qs}^n & -V_{ds}^n & V_{qs}^p & -V_{ds}^p \end{bmatrix} \begin{bmatrix} I_{ds}^p \\ I_{qs}^p \\ I_{ds}^n \\ I_{qs}^n \end{bmatrix} \quad (7)$$

2.4 Proposed definition of instantaneous stator output reactive power

The instantaneous stator output reactive power can be developed based on a set of voltages lagging the input voltages by 90° [2]. A complex quantity, T_s referred as a quadrature complex power is defined and given in (8). The instantaneous stator output reactive power $q_s(t)$ is equivalent to the real part of T_s [2].

$$T_s = \frac{3}{2} V_{ds}^s I_{dq}^{s*} = -\frac{3}{2} (j e^{j\omega t} V_{dq}^p + j e^{j\omega t} V_{dq}^n) (e^{j\omega t} I_{dq}^p + e^{-j\omega t} I_{dq}^n)^* \quad (8)$$

$$q_s(t) = \text{Re}\{T_s\} = Q_{so} + Q_{sc2} \cos(2\omega t) + Q_{ss2} \sin(2\omega t) \quad (9)$$

$$\begin{bmatrix} Q_{so} \\ Q_{ss2} \\ Q_{sc2} \end{bmatrix} = \frac{3}{2} \begin{bmatrix} V_{qs}^p & -V_{ds}^p & -V_{qs}^n & V_{ds}^n \\ V_{ds}^n & V_{qs}^n & V_{ds}^p & V_{qs}^p \\ -V_{qs}^n & V_{ds}^n & V_{qs}^p & -V_{ds}^p \end{bmatrix} \begin{bmatrix} I_{ds}^p \\ I_{qs}^p \\ I_{ds}^n \\ I_{qs}^n \end{bmatrix} \quad (10)$$

Comparing matrix (5) and (10), the relationship between instantaneous stator active and reactive power is deduced in (11)

$$Q_{ss2} = P_{sc2}, \quad Q_{sc2} = -P_{ss2}$$

$$\Rightarrow \sqrt{(Q_{ss2})^2 + (Q_{sc2})^2} = \sqrt{(P_{ss2})^2 + (P_{sc2})^2} \quad (11)$$

Therefore, ripple of instantaneous stator active and reactive power have the same magnitude.

3. Comparison using Ripple-free Stator Power Control Algorithm

In this paper, the characteristics of two instantaneous reactive power definitions are compared using the ripple-free stator active power control algorithm in DFIG. Ripple-free stator power control algorithm is achieved by nullifying oscillating components of the instantaneous output active power of stator as shown in (12).

$$P_{ss2} = 0, \quad P_{sc2} = 0 \quad (12)$$

The rotor current reference values are calculated by using in (13), (14). Equation (13) corresponds to the conventional definition while eq. (14) is for the proposed definition

$$\begin{bmatrix} P_{so} \\ Q_{so} \\ P_{ss2} \\ P_{sc2} \end{bmatrix} = \frac{3}{2} \begin{bmatrix} V_{ds}^p & V_{qs}^p & V_{ds}^n & V_{qs}^n \\ V_{qs}^p & -V_{ds}^p & V_{qs}^n & -V_{ds}^n \\ V_{ds}^n & -V_{qs}^n & -V_{ds}^p & V_{qs}^p \\ V_{qs}^n & V_{ds}^n & V_{ds}^p & V_{qs}^p \end{bmatrix} \begin{bmatrix} \frac{1}{\omega L_s} \begin{bmatrix} V_{qs}^p \\ -V_{ds}^p \\ -V_{qs}^n \\ V_{ds}^n \end{bmatrix} \\ -\frac{L_m}{L_s} \begin{bmatrix} I_{dr}^p \\ I_{dr}^n \\ I_{qr}^n \\ I_{qr}^p \end{bmatrix} \end{bmatrix} \quad (13)$$

$$\begin{bmatrix} P_{so} \\ Q_{so} \\ P_{ss2} \\ P_{sc2} \end{bmatrix} = \frac{3}{2} \begin{bmatrix} V_{ds}^p & V_{qs}^p & V_{ds}^n & V_{qs}^n \\ V_{qs}^p & -V_{ds}^p & -V_{qs}^n & V_{ds}^n \\ V_{ds}^n & -V_{qs}^n & -V_{ds}^p & V_{qs}^p \\ V_{qs}^n & V_{ds}^n & V_{ds}^p & V_{qs}^p \end{bmatrix} \begin{bmatrix} \frac{1}{\omega L_s} \begin{bmatrix} V_{qs}^p \\ -V_{ds}^p \\ -V_{qs}^n \\ V_{ds}^n \end{bmatrix} \\ -\frac{L_m}{L_s} \begin{bmatrix} I_{dr}^p \\ I_{dr}^n \\ I_{qr}^n \\ I_{qr}^p \end{bmatrix} \end{bmatrix} \quad (14)$$

The simulation is made based on the operating condition specified in Table I. The result is obtained under the grid voltage of single-phase line-to-ground fault in primary side of delta-wye transformer and power factor of 0.9 lagging.

TABLE I
Parameters of DFIG Wind Power System

Parameter	Value	Parameter	Value
Rated power(MW)	1.5	Stator resistance(mΩ)	1.4
Rated voltage(line)(V)	575	Rotor resistance(mΩ)	0.992
Frequency(Hz)	50	Stator leakage inductance(μH)	89.98
Inertia(kg m ²)	25	Rotor leakage inductance(μH)	82.09
Pole pairs	2	Magnetizing inductance(mH)	1.53
Rated wind speed(m/s)	12	DC link capacitance(mF)	76

TABLE II
Comparison of instantaneous active, reactive power, and power factor

	Active power		Reactive power	
	0 Hz	100 Hz	0 Hz	100 Hz
Conventional	668 kW	16 kW	303 kVAR	913 kVAR
Proposed		16 kW	318 kVAR	10 kVAR

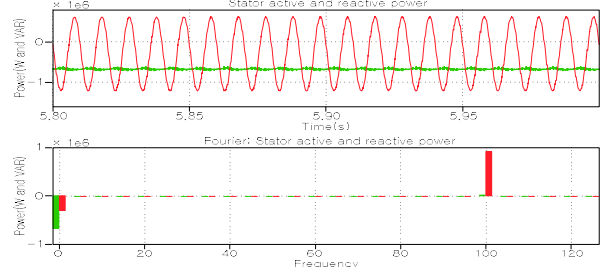

Fig 2 Instantaneous active and reactive power of stator (Conventional definition)

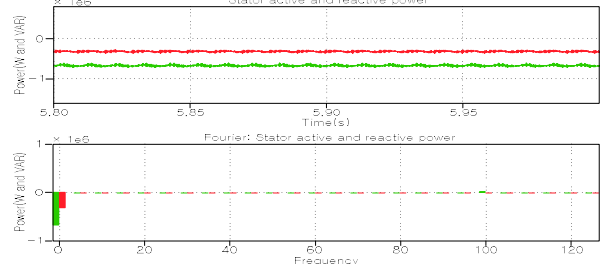

Fig 3 Instantaneous active and reactive power of stator (Proposed quadrature complex power definition)

As noted in a Fig.2 and 3, instantaneous stator reactive power definition using quadrature complex power generates the same ripple sizes of instantaneous stator active and reactive power.

4. Conclusion

This paper compares two instantaneous reactive power definitions for DFIG wind turbine with a back-to-back three-level neutral-point clamped voltage source converter under unbalanced grid conditions. Two different instantaneous reactive power definitions have been devised based on conventional complex power and quadrature complex power, respectively. Two reactive power definitions are compared in terms of ripple size of reactive power. Instantaneous reactive power definition based on quadrature complex power provides same ripple size of both instantaneous stator active and reactive power. The comparison result of two instantaneous reactive power definitions are verified through the simulation.

This work was supported by the National Research Foundation of Korea(NRF) grant funded by the Korea government(MSIP)(No. 2010-0028509)

References

- [1] E. Muljadi, T. Batan, D. Yildirim, and C.P. Butterfield, "Understanding the unbalanced-voltage problem in wind turbine generation," *IEEE IAS Conf Proc*, pp. 1359-1365, 1999.
- [2] Y. S. Suh and T. A. Lipo, "Control scheme in hybrid synchronous stationary frame for PWM AC/DC converter under generalized unbalanced operating conditions," *IEEE Transactions on Industry Applications*, vol. 42, no. 3, pp. 825-835, May/June 2006.
- [3] L. Fan, H. Yin, and R. Kavasseri, "Negative sequence compensation techniques of DFIG-based wind energy systems under unbalanced grid conditions," *IEEE Power Electronics and Machines in Wind Applications*, June 2009.
- [4] L. Xu and Y. Wang, "Dynamic Modeling and Control of DFIG-Based Wind Turbines under unbalanced network conditions," *IEEE Transactions on Power Systems*, vol. 22, no. 1, pp. 314-323, February 2007.