

# KRRI

## Characteristics of Bogie Dynamic Simulator of KRRI

\* 1 \* 2  
 C.W. Lee(cwlee@kri.re.kr)<sup>1</sup>, \* J. C. Kim(jckim@kri.re.kr)<sup>2</sup>

Key words : Bogie dynamic simulator, System performance test, KRRI

1.

Table 1 The inside and outside of the country Bogie Dynamic Simulator specification comparison

Items	Nation	France	Japan		China	Korea
		Vitry re-search institute	RTRI	NTSEL	South-west Jiaotong Univ.	KRRI
number of shaft		4	4	2	4	2
max. speed [km/h]		500	500	220	500	420
roller dia. [mm]		1000	1500	1200	1200	1376
gauge [mm]		1430 1680	1000 1676	1067 1435	1430 1680	1430 1680
wheelbase [mm]		1450 2400	1600 2100	1400 2500	1450 2400	1450 2400
max. axle load [tonnes]		20	20	15	25	20
running stability -straight		O	O	O	O	O
running stability -curve		X	X	O	X	X
Derailment coefficient test		O	O	X	O	O
lateral displacement test		O	O	X	O	O
vertical displacement test		O	O	X	O	O
twist		O	O	X	O	O

Fig. 1 KRRI

Base/Housing assembly, Main shaft/roller/pillow block bearing assembly, Drive Shaft (Intermediate Shaft) and Motor Assembly, Parking Structure, Longitudinal Restraint Safety Support Structure

(drives),

DAS

380/220V 60Hz 3-Phase 4-Wire :

780kW /

(supervisory Control System)

(Vibration control system)  
 Vibration control system 5 7

(Data Acquisition System)  
 LabView  
 DAT tape CD-ROM(R/W)  
 16- , 5 kHz (bandwidth)  
 (anti-aliasing filters) 64

가 EH



Parking Structure



Roller Module



Actuator



Bearing Lube Module



Hydraulic Oil System



Safety Structure & Restraint



Interface Bed & Bogie



Lifting Crane

Fig. 1 Important component of bogie dynamic simulator

3. /  
 KRRI

가 Fig. 2

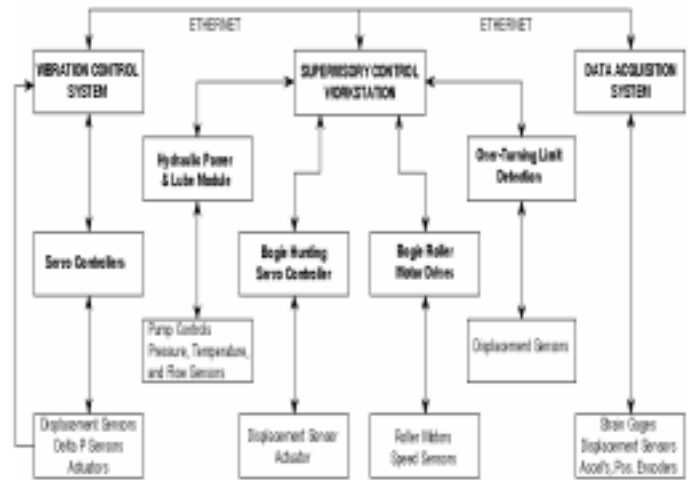

Fig. 2 Control and DAS system diagram

Fig. 3 /

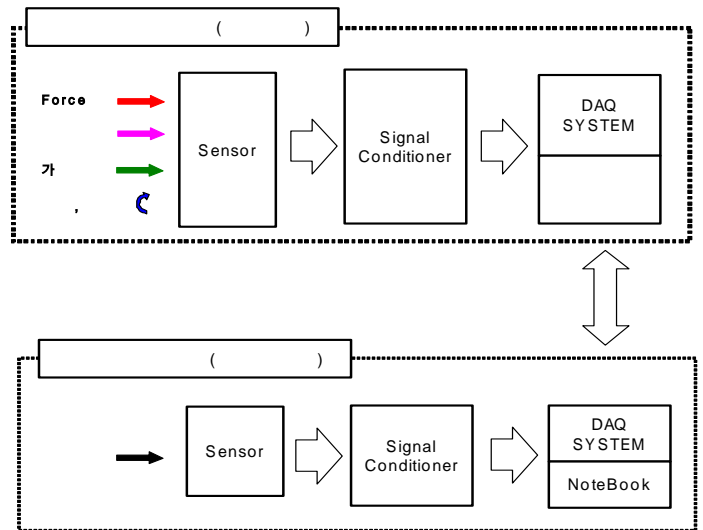

Fig. 3 Vibration and noise measuring system diagram

4.

KRRI

가 가

1. 유원희, 이찬우, 김재철외, “차량성능향상핵심기술개발,” 한국철도기술연구원 2006년 보고서, pp. 153-172, 2007.