

# 과장 가변형 OTDR를 이용한 상시 수동형 광가입자망 모니터링 방법

## In-Service PON Monitoring Method using Tunable OTDR

한수옥\*, 김동환\*, 박창수\*\*

\*Korea Photonics Technology Institute, \*\*Gwangju Institute Science and Technology  
swookhann@kopti.re.kr

Passive optical network (PON)<sup>(1)</sup> is a promising architecture in optical access networks. To guarantee the performance of access service in the high capacity PON, the monitoring techniques through both fault diagnosis and maintenance for the point-to-multipoint architectures have to be prepared under in-service state. However, the PON have difficulties in the in-service monitoring and maintaining. Conventional optical time domain reflectometer (OTDR) can not analyze each backscattered signal from multiple individual distribution lines since the OTDR utilizes the time-length measurement method for the point-to-point architecture. Furthermore, the acquired OTDR level of the power splitter (PS)-PON is smaller than the actual value of the event on the branch of the multipath PS-PON<sup>(2)</sup>. Multiple PS-PON will be applied and will cover a large number of business subscribers in the near future; therefore, a monitoring technique for multiple PS-PON with multi-branched PS will be required for realizing the PON service with network evolution. The proposed monitoring technique can use both a tunable OTDR and several reflection filters<sup>(3)</sup> to diagnose the individual branch of the multiple PS-PON. The tunable OTDR is located in the central office. The centralized monitoring method is cost effective for the multiple PS-PON maintenance with single monitoring system. In this paper, we report the diagnosis technique of the multiple PS-PON using a tunable OTDR and reflectors with FBGs as the wavelength dependent reference reflection. The wavelength dependent Bragg reflection of individual branch is not accumulated from other branch span. Therefore, the FBG helps discern an individual event of the multipath structure of the PON using a tunable OTDR for a centralized monitoring in collaborate with information of Rayleigh backscattered power. The experimental results of the centralized monitoring technique are also presented for the multiple PS-PON under 10-Gbit/s in-service.

Table1. Experimental wavelength plans of the PS-PON

Items	Data Band	Monitoring Band
PS1	1508-1512	1548-1552
PS2	1529-1531	1569-1571

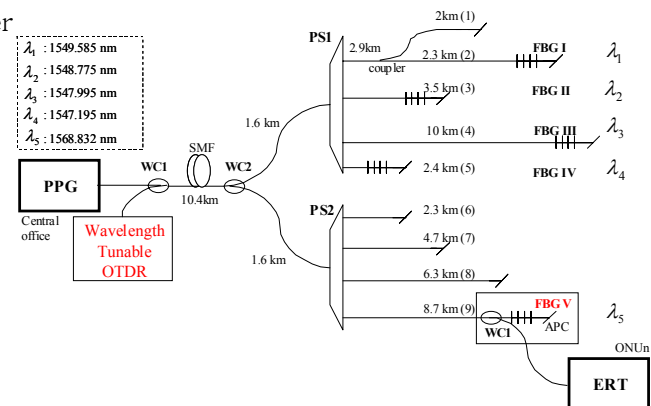

Fig.1 Schematic diagrams of PON monitoring technique.

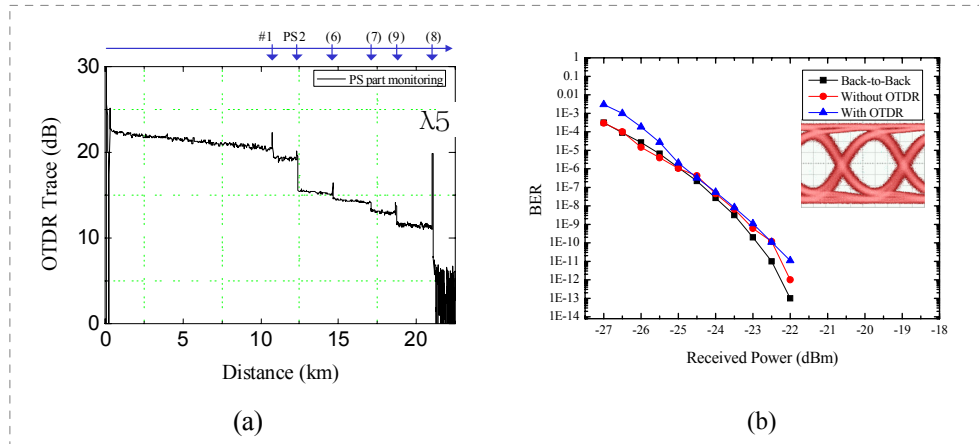

Fig. 2 PS-PON monitoring: (a) OTDR trace; (b) BER measurements.

The experimental setup for the monitoring technique for multiple PS-PON under in-service state is shown in Fig. 1. The monitoring technique has a centralized maintenance works using the tunable OTDR as well as FGBs in a capacity of the remote identifiers or markers. To diagnose the state of the double PS-PON, for example, we used two subbands for the monitoring of the PON. One is for PS1 monitoring band, the other is for PS2 monitoring bands as shown in Table 1. The OTDR trace shows several events through the Bragg reflection of  $\lambda_5$  (8.74 km away from PS2) on the multiple PS-PONs as shown in Fig. 1. The first peak of the OTDR trace, #1 in Fig 2(a) is a result of the wavelength selective coupler (indexing WC2 in Fig. 1) to branch out into PS1 and PS2. The second peak is the power splitter PS2. The service data rate is 10-Gbit/s using a 95% confidential level at  $2^{31}-1$  pseudo-random binary sequences for future PON environments. The PS-PON has a service wavelength source among several ONUs with 1530.5 nm. Under the proposed monitoring, the optical access service from the central office to each ONU should be isolated against the monitoring works. The bit-error-rate (BER) measurement under for ONU of the multiple PS-PON is achieved using a pulse pattern generator (PPG) and an error rater (ERT). For the case of the multiple PS-PONs, with-OTDR case has a spontaneous Raman scattering power penalty of less than 0.2 dB at  $10^{-11}$ , as compared with the without-OTDR as shown in Fig. 2(b). We have demonstrated a monitoring technique for the multiple PS-PON with high capacity services as well as high quality of service level by using both a tunable OTDR and several FBG reference reflections. The FBG helps discern an individual event of the multi-path PON for the monitoring, in collaborate with information of Rayleigh backscattered power.

The proposed monitoring technique can be applied for the various PON architectures under each PON configurations. Therefore, through the fault diagnosis and maintenance with the help of the proposed monitoring method, the performance of the multiple PS-PON service for a number of subscribers can be guaranteed.

1. S.S. Wagner et. al, "Technology and system issues for a WDM-based fiber loop architecture," JLT 7, 1759-1768, (1989).
2. J. Laferriere, et. al, "Original method for analyzing multipaths networks by OTDR measurement," OFC'97, TuT4, (1997).
3. N. Araki, et. al, "Add-on filtering technology for L/U-band extended optical fiber line testing systems using wideband and high cutoff chirped FBG," OFC'2004, ThW4, (2004).