

# A CONSTRUCTION PROCESS IMPROVEMENT MODEL USING CONSTRUCTION FAILURE INFORMATION

Yongseok Jeon<sup>1</sup>, and Chansik Park<sup>2</sup>

<sup>1</sup> Researcher, Institute of Construction Industry and Technology, Chung-Ang University, Seoul, Korea

<sup>2</sup> Professor, School of Architecture & Building Science, College of Engineering, Chung-Ang University, Seoul, Korea

Correspond to [naiss90@yahoo.co.kr](mailto:naiss90@yahoo.co.kr)<sup>1</sup>, [cpark@cau.ac.kr](mailto:cpark@cau.ac.kr)<sup>2</sup>

**ABSTRACT** : The construction failures can be decreased through continuous improvement of construction process based upon the information of construction failures. Herein, the information of construction failures can be utilized as the key factor for identifying and enhancing various ineffective construction processes that can prevent failures. This research proposes a process model for the continuous improvement of construction processes by using construction failure information. Extensive reviews and analyses of literatures related to construction failures are performed to investigate its definition, type, cause, and lessons learned. This research adapts process modeling methodology and case-based reasoning for the development of the proposed CIMCP(continuous improvement model of construction process), and then suggests its framework that contains modules of case retrieval, case index, and case adaptation.

*Key words* : Construction Failure, Construction Failure Information, Process Improvement, Case-based Reasoning

## 1. INTRODUCTION

### 1.1 Background

The construction industry has been making great efforts for its technology enhancements and innovations by applying new design concepts and developing advanced technologies, which however contains the possibility of failure in the background. Researches on construction failures have been focused on the effective utilization of construction failure information through the standardization of its collection and dissemination process in the construction industry. However, suggestions and results from those researches are not enough for industry practitioners to apply the information for the enhancement of construction process.

If the construction failure information can be systematically obtained and disseminated with enough information, it would be one of the catalysts for the improvement of construction process. With this systematic failure information, the poor area of construction process can be identified and also be utilized for the key factors on redesign of the construction process. Current practices on the (re)design of construction process mainly depends on subjective judgments or engineer's experience for which the failure information is not considered enough. It can be said that an effective methodology to support (re)designing process, being considered the construction failure information, is needed in the structured manner [1-4].

The objective of this research is structuring construction failure information systematically and suggesting a model for the improvement of construction process, which can be

utilized effectively in order to minimize and prevent failure reoccurrence in the construction industry.

### 1.2 Research scope and methodology

In order to achieve the objective of this study, the following scope and methodology are determined.

1) The current status of the construction failure research and its application problem is investigated through an extensive literature survey and review on this subject. And also a classification format is suggested to assist the collection of failure information.

2) The framework of the continuous improvement model of construction process with failure information is proposed, adapting case-based reasoning and process redesign methodology.

## 2. DEFINITION AND CLASSIFICATION OF CONSTRUCTION FAILURES

### 1) Definition of construction failures

Construction failures are defined by various researchers [5, 14-16]. In general, construction failures can be defined as a comprehensive concept involving safety problems, performance deterioration and latent deficiency as well as structural collapse and deficiency.

### 2) Classification of construction failures

Researches on failure information classification focus mainly on the standardization and generalization of construction failure. It suggests that the failure information be well structured for the project team to analogize past failure cases by expressing the situation of construction

failure.

Kaminetzky(1982) insisted that construction failure information usually involves who, where, what, when, why and how[5]. Eldukair(1991) analyzed construction failures occurred in the United States during 1975 to 1986, according to the followings: project facilities, element of failure, type of failure, cause of failure, consequences, control of failures[6]. Yates(2002) suggested an investigation format for construction failures including type of project, material or equipment involved, injuries or fatalities, description of failure, and lessons learned[7]. "Guidelines for Failure Investigation" published by the Technical Council on Forensic Engineering of the ASCE(1989), classifies a failure with respect to the extent and type of damage into four types: safety, functional, latent, and ancillary[8]. Park(2003) also classified construction failure information into situation, cause, and countermeasures[9].

### 3. APPLICATION PROBLEMS OF CONSTRUCTION FAILURE INFORMATION

Construction failure information could(and should) be used for preventing a failure on the future projects. However, there is no structured methodology developed for that purpose. Many researchers argue that the improvement of construction process using failure information is needed for preventing the recurrence of failures, and that it can be accomplished by applying advanced technologies such as data-mining and case-based reasoning.

#### 3.1 Necessity on application of AI technology

In order to prevent construction failure from recurring, at first, the lesson learned from failure should be collected in a structured manner, and then the obtained information should generate a new knowledge to improve construction process.

Vanderville(1999) and Kajihara(1993) insisted on improving the construction process through the lesson learned from success or failure. Weber(2001) and Soibelman(2003) indicated that advanced AI technologies such as case-based reasoning and data-mining should be applied to generate new knowledge, which can serve for a catalyst for the improvement of the construction process [10,11]. However, they investigated the problem of the current information system on lessons learned and emphasized the necessity on the AI application. And they just described the basic concept about information system development.

#### 3.2 Process redesign by case-based reasoning

The one of main purpose of case-based reasoning is to express the human's reasoning process in a model type without comprehensive previous experience and background knowledge. However, research in construction field related to case-based reasoning mainly focus on an expression and retrieval of case[12,13]. There are not enough researches regarding case adaptation of modifying a case to fit the target process and case reuse of improving a process through generating a new process.

In order to solve these problems and limitations of past

researches, it is needed that an effective methodology, which can integrate construction failure information with case-based reasoning. The conceptual diagram for the improvement of construction process using the failure information is illustrated in Figure 1.

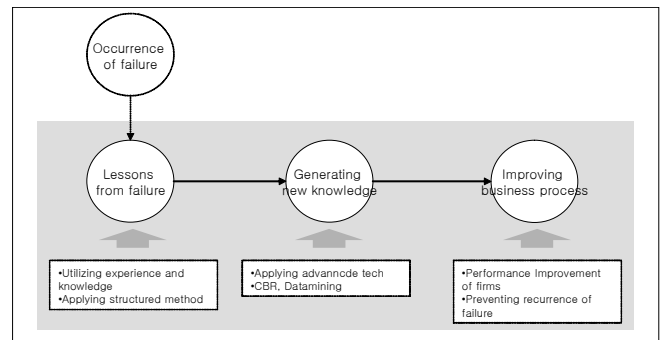

Figure 1. Conceptual diagram of construction process improvement by using failure information

### 4. FRAMEWORK OF CONSTRUCTION PROCESS IMPROVEMENT MODEL

The model consists of the improved construction process(To-be) to prevent construction failure from the existing construction process(As-is) by utilizing construction failure information and case-based reasoning. Figure 2 illustrates the conceptual framework of the continuous improvement model of construction process (hereinafter CIMCP).

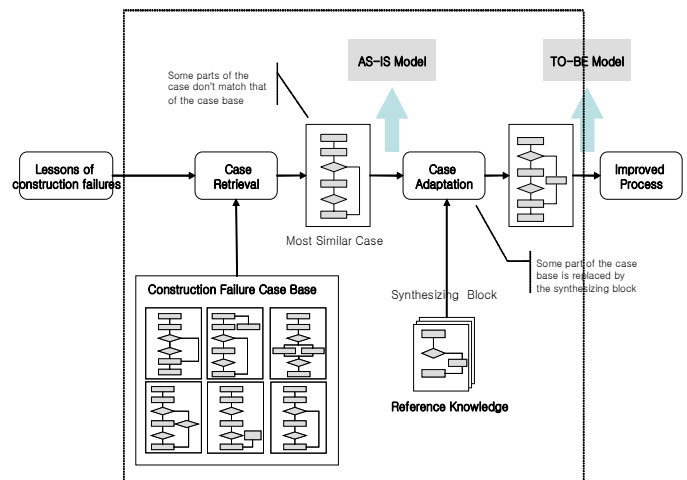

Figure 2. Conceptual Structure of CIMCP

#### 4.1 Structure of CIMCP

If a construction failure occurs, the construction process caused the failure is to be identified and corresponding improvement method is to be studied in depth. Lessons from the construction failure are utilized as a basic data to improve the construction process. Following that, the objectives of process improvement to prevent construction failure is to be set up, and then a case is to be retrieved from the case base, in which the construction construction

processes are being stored. The most appropriate case to the target process is to be deduced by the retrieval rule, and it becomes the optimal case.

However, the optimal case may be perfectly coincided with the target process, or may not. In case of the latter, the project team has to add, delete, or substitute the process activity to cope with the target process. This is the process to add or to delete process as a whole or a part utilizing the case adjustment function of the case-based reasoning. Passing through this process, the AS-IS Model of a target process is to be generated.

But the retrieved case may perfectly reflect lessons of the target context, or may not. In case, the lessons may not perfectly reflected, then synthesizing block is to be formed by retrieving the activity block to conform to the respective lesson utilizing the reference knowledge from the improved process model, and form the AS-IS Model through integrating it to the To-Be Model. And also the information flow in the model may be displayed using the IDEF0 model technique, which is a brand-new process to prevent construction failure, based on the formed To-Be Model related to the present improvement target process, utilizing the lessons of construction failure.

#### 4.1.1 Case Knowledge Base

case knowledge base is to have the TO-BE Model to be formed from the respective AS-IS Model and various AS-IS Models, and it describes an actual context of construction failure and the lessons. The objectives of retrieval of case knowledge basis are facilities and elements, time of failure, type of failure, cause of failure and lessons of failure. Here, the lessons of construction failure are to be set up as the target process for the process improvement.

The context of construction failure can be displayed as a form of frame. Construction failure is to be occurred at the other general facilities for facility and elements, time of failure phase is to be construction phase, type of failure is to be safety failure and functional failure, cause of failure is to be improper structural design of timbering in technical area, and insufficient communication between the contractors in management area.

Lessons are to be a thorough review on structural design in technical area, coordination between work subjects in management area, an advanced review of the CMr, and an educational training of engineer in education area. Table 1 shows Index structure of case base.

#### 4.1.2 Reference Knowledge

The most difficult thing in the process of redesigning of construction process centered on the construction failure information is forming the alternative process. Namely, since the construction process abstracted through the case retrieval may not perfectly coincide with the target process during transforming the AS-IS Model of CIMCP into the To-Be Model, it is to be coincided perfectly with the target process utilizing the reference knowledge, if possible.

**Table 1.** Index structure of case base

Level 1 Case Base	Level 2 Group Element	Level 3 Individual Element
Case Base	Facilities and Elements	civil and public facilities
		industrial facilities
		administrative, commercial, and security facilities
		welfare and health facilities
		resort and entertainment facilities
		religion facilities
		educational, scientific, and information facilities
		residential facilities
	time of failure	planning
		design
		construction
		maintenance
	type of failure	safety failure
		functional failure
		latent failure
	cause of failure	technical
		managerial
		mixed
	lessons of failure	technical
		managerial
		educational

Formation of the reference knowledge is to be applied for the case in which the formed AS-IS Model is not perfectly coincided with the target context and is helping to form the To-Be process easily. The process is classified into three of technical, managerial, educational areas, and the abstracted case is consisted of Activity Name, Activity Actor, Activity Input, and Activity Output, as the same with the activity block in the case base(see Table 2). The project team extracts detail activity block to supplement the process through retrieving the terminologies in the respective criteria utilizing the referential information, and form the synthetic block, and the synthetic block becomes the basic information to form the To-Be Model.

**Table 2.** Sample Activity Block

Activity ID	Activity Name	Activity Actor	Activity Input	Activity Output
A10	Client's brief	Government	-	Basic design
A20	Basic design	Designer	Client's brief	Detailed design
A30	Design review	Government	Basic design	Detailed design
.....	.....	.....	.....	.....
A <sub>n-1</sub>	Making specification	Designer	Detailed design	Review contract document
A <sub>n</sub>	Review contract document	Designer	Making specification	Final Review

#### 4.2 Information Flow of CIMCP

The information flow of the model can be manifested as the Figure 3 using the IDEF0 modeling technique in the

process of building the CIMCP. It is forming the AS-IS Model for the present reformation target process utilizing the construction failure information, and from this, it is showing the concept to present the TO-BE Model, a brand-new process to prevent construction failure.

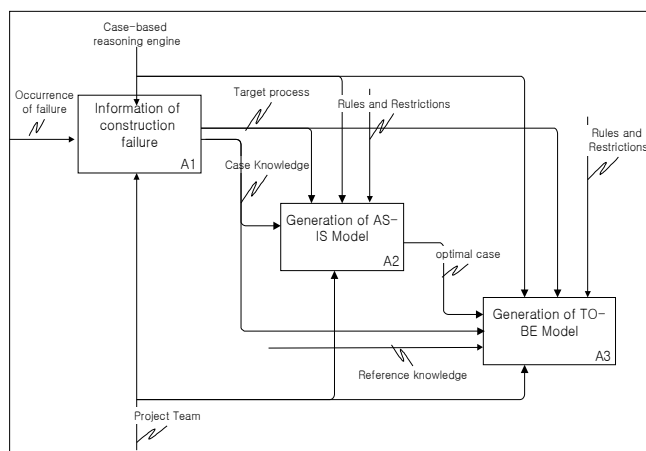

Figure 3. Information flow of CIMCP

#### 4.2.1 Information of Construction Failure(A1)

An appropriate case to reflect the present improvement target process is to be retrieved amidst the past cases related to the construction failure information, and the abstracted case is to present a solution to coincide with improvement of the brand-new construction process. Each case of construction failure has diverse environment to assort recognizable characteristics and properties. Namely, it assort information such as lessons, time of failure, cause of failure, type of facility and element at which the construction failure occurred.

Construction failure information(A1) has the function to form lessons, time of failure, cause of failure, type of facility and element at which the construction failure occurred. The information to be formed in this stage act as the retrieval in the case base, and become the basic information to form the AS-IS Model later.

#### 4.2.2 Generation of the AS-IS Model (A2)

This is the process to form the AS-IS Model, after analyzing the relevance between the context of target process and the case retrieved, and to retrieve the optimal case to coincide with the target process at most from the case base, and the target process to improve the existing process is to be formed, based on the construction failure information.

#### 4.2.3 Generation of the To-Be Model(A3)

This is the stage to form the To-Be Model using the reference information and the AS-IS Model. The retrieved process may reflect the target process perfectly, or may not. If it is not coincided each other perfectly, the activity block to coincide with the target process is to be deduced utilizing the reference information, and the project team shall create a synthetic block through their professional judgment. The To-

Be Model is to be formed by mixing synthesizing block and the AS-IS Model of the final target process.

## 5. CONCLUSIONS

The overall objective of this research was to establish the structure of construction failure information, and to suggest the model that can improve the construction process so that prevent construction failure from recurrence.

The current status of the construction failure research and its application problem was investigated through an extensive literature survey and review on this subject. And also a classification format was suggested to assist the collection of failure information.

And then, the framework of the continuous improvement model of construction process with failure information was proposed, adapting case-based reasoning and process redesign methodology. The framework of CIMCP contained three parts: construction failure information module, generator of As-Is model, and generator of To-Be model.

And also, three issues were recognized in the process of this study as requiring more research. The following describe the issues in detail: First, information classification and case collection has to be made through identifying the mechanism of construction. Secondly, the structured rules and restrictions on building modules such as case retrieval, As-Is model, To-Be model, synthesizing block need to be made. Thirdly, development, validation and implementation of the model through case study are required.

## REFERENCES

- [1] Vandeville, Joseph V. and Shaikh, Muzaffar, "A Structured Approximate Reasoning-Based Approach for Gathering Lessons Learned Information from System Development Projects," *Systems Engineering*, Vol.2, No.4, pp.242-247, 1999
- [2] Kim, Sangil, *Case-Based Reasoning Methodology for Business Process Knowledge Management*, PhD dissertation, KAIST, 2001
- [3] Kajihara, Juichirou, Amamiya Goro, and Tetsuo Saya, "Learning From Bugs," *IEEE Software*, Sept., pp.46-54, 1993
- [4] Hwang, Soonsam, *A Study on the Development and Application of Process Analysis, Design and Evaluation Method*, MS Thesis, Chung-Ang Univ. 1997
- [5] Kaminetzky, Dov, *Design and Construction Failures*, McGraw-Hill, 1991
- [6] Eldukair, Ziad A. and Ayyub, D. M., "Analysis of Recent U.S. Structural and Construction Failures," *Journal of*

- Performance of Constructed Facilities, Vol.5, No.1, ASCE, pp. 57-73, 1991
- [7] Yates, Janet K. and Lockley, Edward E., "Documenting and Analyzing Construction Failures," Journal of Construction Engineering and Management, ASCE, Vol. 128, No. 1, pp.8-17, 2002
- [8] The Technical Council on Forensic Engineering of ASCE, Guidelines for Failure Investigation, ASCE, 1989
- [9] Park, Chansik, Jeon, Yongseok, "A Study on the Establishment of the Construction Failure Information Classification," Journal of Korean Journal of Construction Engineering and Management, KICEM, Vol.4, No.1, pp.97-106, 2003
- [10] Weber, R., Aha, David W. and Becerra-Fernandez, I., "Intelligent Lessons Learned Systems," Expert Systems with Applications, No. 17, pp.17-34, 2001
- [11] Soibelman, Lucio, Liu, Liang Y., Kirby, Jeffrey G., East, E. William, Caldas, Carlos H and Lin, Ken-Yu, "Design Review Checking System with Corporate Lessons Learned," Journal of Construction Engineering and Management, ASCE, Vol.129, No.5, 2003
- [12] Kim Roddis, W. M., Bocox, John, "Case-Based Approach for Steel Bridge Fabrication Errors," Journal of Computing in Civil Engineering, ASCE, Vol. 11, No. 2, pp. 84-91, 1997
- [13] Chua, D. K. H., Li, D. Z. and Chan, W. T., "Case-Based Reasoning Approach in Bid Decision Making," Journal of Construction Engineering and Management, ASCE, Vol.127, No.1, pp. 35-42, 2001
- [14] Horns, H. Murray, "Procedural Changes in Design and Construction to Reduce," Reducing Failures of Engineered Facilities, ASCE, pp.75-83, 1985
- [15] Janney, Jack R., Guide to Investigations of Structural Failures, U.S. Department of Transportation, Federal Highway Administration, 1986
- [16] Leonards, Gerald, "Investigations of Failures," Journal of the Geotechnical Engineering Division, ASCE, Vol.108, No.2, Feb., pp. 187-246, 1982