

A Human Robot Interactive System “RoJi”

Inbo Shim* and Joongsun Yoon**

* Vacuum Cleaning Division, LG Electronics, Changwon, Korea
(Tel : +82- 19-9203-3566; E-mail: nainbow@lge.com)

**School of Mechanical Engineering, Pusan National University, Pusan, Korea
(Tel : +82-51-510-2456; E-mail: jsyoon@pnu.edu)

Abstract: A human-friendly interactive system, based on the harmonious symbiotic coexistence of human and robots, is explored. Based on interactive technology paradigm, a robotic cane is proposed for blind or visually impaired travelers to navigate safely and quickly among obstacles and other hazards faced by blind pedestrians. Robotic aids, such as robotic canes, require cooperation between humans and robots. Various methods for implementing the appropriate cooperative recognition, planning, and acting, have been investigated. The issues discussed include the interaction of human and robot, design issues of an interactive robotic cane, and behavior arbitration methodologies for navigation planning.

Keywords: Human-robot interaction, interactive technology, robotic cane, shared behavior control

1. INTRODUCTION

Robotic aids, used widely in areas such as health care and home assistance, require cooperation between humans and robots. The proper control commands for such systems would be a combination of autonomous commands from robots and commands from human, rather than either autonomous commands or solely human commands [1-3].

This paper explores a human-friendly interactive system, based on the harmonious symbiotic coexistence of humans and robots. Our goal is to develop a robotic aid system capable of interacting with its environment and eventually with human. Various methods for implementing the appropriate cooperative recognition, planning, and acting have been investigated [4-7].

We outline a set of hardware solutions and working methodologies that can be used for successfully implementing and extending the interactive technology to coordinate human and robots in complicated and unstructured environments. The issues discussed include methodologies for human-robot interactions, design issues of an interactive robotic cane, hardware requirements for efficient human-robot interactions, and behavior arbitration methodologies for navigation planning.

2. A ROBOTIC CANE “ROJI”

The successful and widely used travel aids for the blind are the white cane and the guide dog. Electronic travel aids are also used, but not widely so. By taking advantage of the white cane and the guide dog, we have been developing a robotic aid system, as shown in Figs. 1~2 [8-13].



Fig. 1 An interactive robotic cane “RoJi.”

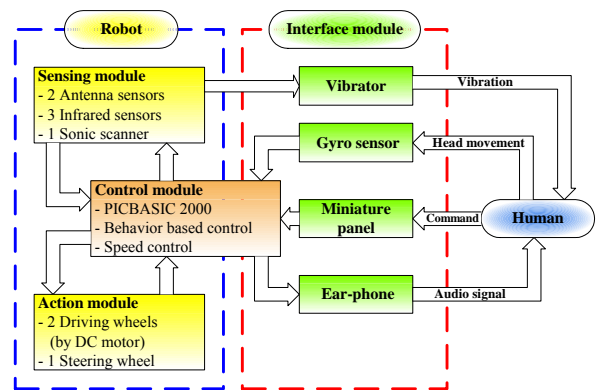

Fig. 2 Configuration of “RoJi.”

The proposed robotic cane, “RoJi,” consists of a long handle, two steerable wheels, a sensor unit that is attached at the distal end of the handle, and an user interface panel. Much like the widely used white cane, the user holds these robotic canes in front of him/herself while walking. The handle is painted in white to mimic white canes. The sensor head, which is mounted on a steerable, powered, two-wheeled steering axle, includes three infrared sensors, two antenna type contact sensors, and a sonic scanner.

The robotic cane, “RoJi,” makes independent decisions concerning the path it takes. However, the user and the cane may wish to go in different directions. The normal operating mode of the constructed robotic cane must include an override feature to allow the blind person to be in control when the need arises. We try to build a system that is capable of interacting with its environment and eventually with humans.

The contents of the robotic cane system and how these components are used to provide desired functional capabilities are described in some detail.

2.1 Control and action module

“RoJi” utilizes an on-board PICBASIC 2000 microcontroller to process sensor information and timer counts and to generate control pulses for the DC servo motor. The PICBASIC 2000 can be easily programmed in Basic with the built-in analog and digital interface functions. The μ -controller is connected to thirty-two (32) digital inputs/outputs, two (2)

PWM (pulse width modulation) outputs, one (1) high-speed pulse counter, eight (8) 10-bit A/D (analog-to-digital) inputs and a 64 Kbytes flash memory [14].

“RoJi” is driven and steered by two powered motors. By this way, it can guide the blind autonomously with sufficient power. The two front-steering wheels of the cane are controlled independently by separate DC motors. One unpowered wheel in the back stabilizes the cane’s stable structure and produces sharper turns.

2.2 Sensing module

“RoJi” has a sensor head unit that is attached at the distal end of the handle to detect obstacles. This sensor head unit consists of an active ultrasonic sensor unit, three infrared sensors, and two antennas for contact sensing. A sensor unit, as shown in Fig. 3, is mounted above the guide wheels of “RoJi.”



Fig. 3 Sensors for “RoJi.”

The active sensing unit mounted above the guide wheels has an ultrasonic sensor driven by a RC motor, as shown in Fig. 3. The unit scans the area ahead of it to efficiently detect obstacles or safe paths and can reduce the missing areas caused by the narrow coverage due to the fixed sensor arrangement. Its scanning angle is $\pm 90^\circ$ wide. The ultrasonic sensor detects any obstacle up to a distance of 250 cm and within a range of angles $\pm 30^\circ$.

An array of three infrared sensors is utilized to detect the convex obstacles blocking the cane’s pathways. These three sensors are arranged in a semi-circular fashion, 30° apart from each other, and can detect any obstacle within a distance of 60 cm. This arrangement is based on the user’s shoulder width. Including the size of the robot platform with the radius of 18 cm, we can assure the safe pathways up to 80 cm wide.

For short-range coverage, additional antennas for contact sensing could effectively complement these infrared sensors and the active sensing unit. Limit switches, angle detectors, or torque sensors attached to these antennas quickly and easily detect dynamic changes in the environment when the potentiometers contact a surface, bend, and send signals [15, 16]. Limit switches were utilized for the earlier prototype of robotic canes [9]. Potentiometers are utilized instead for “RoJi.” [11-13]. Each antenna is arranged between the infrared sensors. It must be made of flexible materials so as not to interfere with navigation when it touches the surface to detect obstacles. Steel was selected for “RoJi,” and the length of each antenna is 22 cm. These antennas are connected to the potentiometer to detect the sudden irregularities of the surface and to react properly to them. Antennas are especially suitable to take advantage of most visually impaired people’s superb tactile information processing capabilities.

2.3 Operator interface module

A miniature panel that can be operated with the thumb allows a user to specify a desired direction of motion, as shown in Fig. 4(a). This operator interface module also lets the user and the cane share information to cooperate with and compensate for each other. The user receives the cane’s obstacle information as different tones of audio signals proportional to the distance and triggers proper navigation command buttons.

The user can point the active sensing unit to his or her viewing direction. The active sensing unit of “RoJi,” as shown in Fig. 4(b), can track the user’s head movements by utilizing a gyroscope sensor attached to his/her head. A semiconductor-type gyroscope, muRata’s ENV-05S, is utilized [17].



(a) A miniature user-interface panel



(b) Gyroscope sensor for head tracking

Fig. 4 User interface for “RoJi.”

Users can recognize the distance and the direction of the obstacles based on audio and gyroscope information. Once the navigation path is determined, the user can control the robotic cane by pressing the buttons on the interface panel. The operator interface module contains four command buttons: “Go Straight,” “Turn Left,” “Turn Right,” and “Stop.” A small motor attached to the panel vibrates back to the user, depending on the ground information. Also, speakers carry alarm sounds to alert the user. The cane benefits from the user’s flexible decision capabilities and his/her tactile and auditory information processing capabilities.

3. NAVIGATION PLANNING

3.1 Shared navigation planning

Pedestrians usually detect obstacles and navigate properly based on visual information. The user’s decisions for proper navigation are based on the user’s a priori, intuitive and heuristic mental processing, instead of precise computations. In contrast, mobile robots’ lack of intuitive nature requires precise geometric information about obstacles and goals. A blind or visually impaired traveler with a white cane and/or a guide dog only require approximate geometric information about obstacles and goals.

Robotic aids, such as robotic canes, require cooperation between humans and robots. The constructed robotic cane is self-steering, based upon the interpretation of its input. The steering command of the robotic cane is based on the absence or presence of obstacles sensed by photo sensors. Without a shared control framework in place, the cane would want to avoid objects such as stairs, doors, or chairs that the user might want to use. The operator's decision making must be included. Clearly the normal operating mode of the robotic cane must be overridden to allow the person to be in control when the need arises.

The proper control commands for such a system would be a combination of autonomous commands and commands from humans, rather than either autonomous commands or solely human commands. Our robotic cane has two control modes, a robot control mode (RCM) and a user control mode (UCM).

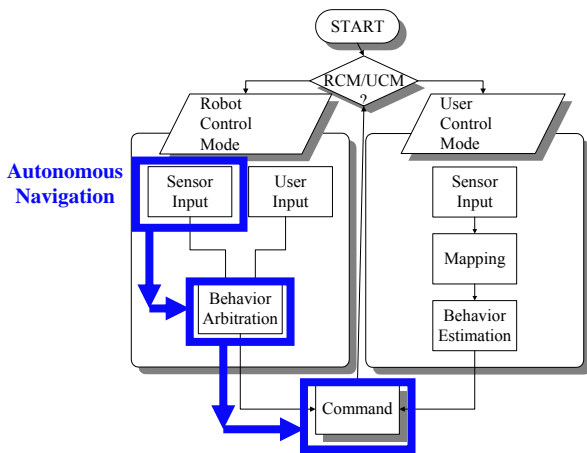

Fig. 5 Control flow of "RoJi."

This shared control framework is as shown in Figs. 5~6 [18-23].

The cane's navigation control allows the robot to detect obstacles and navigate safely and quickly based on the robot's autonomous commands and the user's input commands. User can initiate a RCM or a UCM by switching a navigation mode button. The cane's RCM is an extended autonomous navigation mode, which includes the user's intention. The traditional autonomous navigation mode can be described as a flow in bold as shown in Fig. 5. The cane's UCM lets the user navigate safely when the cane and the user make conflicting and/or difficult decisions to follow.

3.2 Robot control mode

The robot control mode (RCM) contains three different behaviors: "Follow Human Order," "Avoid Obstacles," and "Move to Safe Path."

The first behavior, "Follow Human Order," determines the navigation direction based on the user's intention. The cane performs the same actions as the user's commands: "Go Straight," "Turn Left," and "Turn Right."

The second behavior, "Move to Safe Path," determines the navigation direction for a safe path. The active sonar scans the area ahead of it from left to right to decide the safe path direction that is furthest direction from obstacles. The cane navigates following such directions. Considering the detection range of the ultrasonic sensor, the area is divided into three zones. The scanning period is 1 sec. The safe path is set to be the latest zone detected when the distance from the obstacle for each scanning direction is the same or further than the maximum detection range of 250 cm. When the active sensing unit scans the area ahead of it and the left zone has the maximum possibility avoidance, the cane turns left and follows the corresponding path.

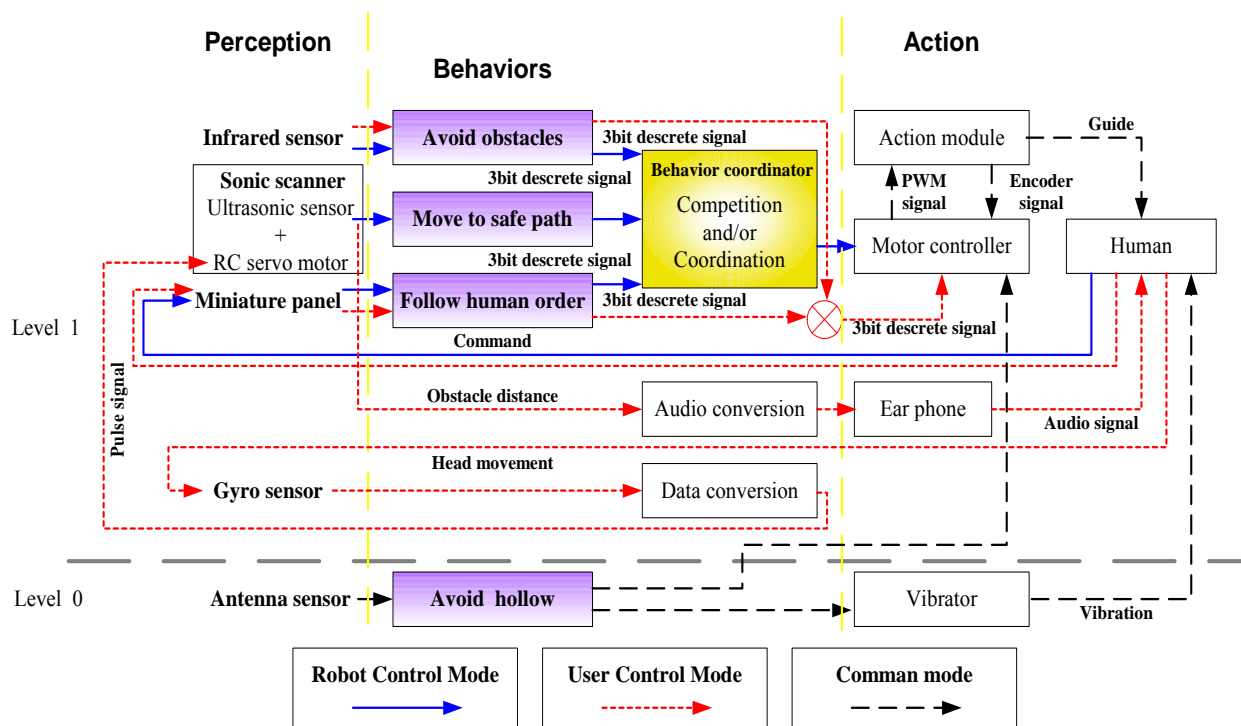

Fig. 6 Control architecture of "RoJi"

The third behavior, “Avoid Obstacles,” determines the navigation direction by moving around obstacles. The RCM models the possible infrared sensor states, S1 or S0. S1 and S0 represent the presence and the absence of a detected obstacle, respectively. With an array of three sensors, the RCM of the robotic cane represents eight possible states. Additional sensors could be utilized to plan different obstacle-avoidance strategies. State changes in the RCM are triggered by sensor events at each discrete time interval. To avoid colliding with obstacles, the RCM generates controller events in the form of a discrete representation of the desired turning angle.

The output of each behavior is channeled into a coordination mechanism that consists of logic operators. The coordinator produces an appropriate overall motor response for the robotic cane at any point in time, given current existing environmental stimuli including human orders. Through coordination and competition of behaviors, the coordination module arbitrates proper behaviors to produce an appropriate overall motor response. The RCM, described as a stimulus-response diagram, is as shown in Fig. 7 [23-25].

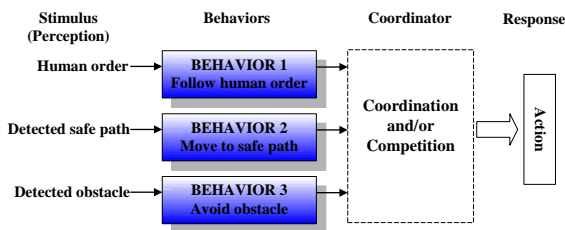

Fig. 7 Stimulus-response diagram for “RoJi.”

Earlier version of navigation planning has been based on a table lookup method. The navigation rules are tabulated and the cane performs navigation following these rules. Each behavior is represented by a 3-bit discrete signal. The first behavior includes three user’s commands. The second behavior includes three directions of safe path. The third behavior includes seven states of sensors. The possible navigation rules are 36. This rule-based method suffers the programming inefficiencies when the behaviors get increased due to the nature of constructing the corresponding rules [9, 19-22].

As an alternative method, a heuristic behavior arbitration method based on logic operator has been proposed shown in Fig. 8. The behavior arbitration procedure is as follows. A “NOT” operation flips the digital signals of the first behavior and the second behavior. This conforms the stimulus condition for the third behavior. An “AND” operation finds a common stimulus for the first behavior and the second behavior. This common stimulus can be a virtual obstacle. An “OR” operation applies the presence of both real obstacles and a virtual obstacle. When the output status of the coordinator is [0 1 0], the user input overrides the autonomous command. Otherwise, the autonomous commands are performed [21-23].

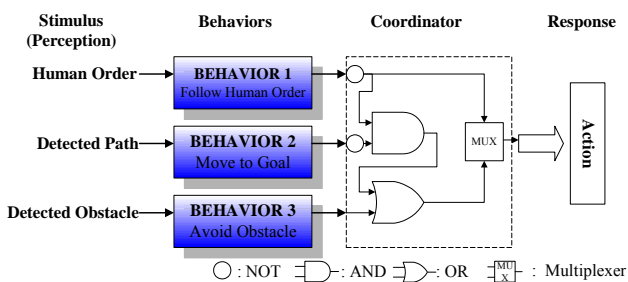

Fig. 8 A heuristic navigation strategy coordinator.

The construction of behavior coordinator, based on this trial and error method, becomes extremely difficult when robot systems and behaviors are more complicated. We can overcome this problem by applying an evolutionary approach to construct behavior coordinator in automatic and efficient ways.

Each behavior is represented by a 3-bit discrete signal. Behavior coordinator can be constructed as a combination of logic operators. A gene representing each logic operator consists of two or three inputs to a logic operator, a type of logic operator, and one output from a logic operator, as shown in Fig. 9. Multiplex has three input connections and all the other logic operators have two input connections. Allowed logic operators: AND, OR, MUX, NAND, NOR, XOR are numbered as 1 to 6, respectively [23, 25].

The evolution algorithm used to evolve behavior coordinator is a simple form of $(1+\lambda)$ evolutionary strategy, where λ is 5. The maximum number of logic operators has been set to 15 for the computational efficiencies. The maximum number of generation is set to 10,000. The mutation rate is 20%, i.e. 3 out of 15 logic operators. The lookup table presents a guideline for the proper actions a robotic cane can take. Fitness can be evaluated counting matching rules from this table [26].

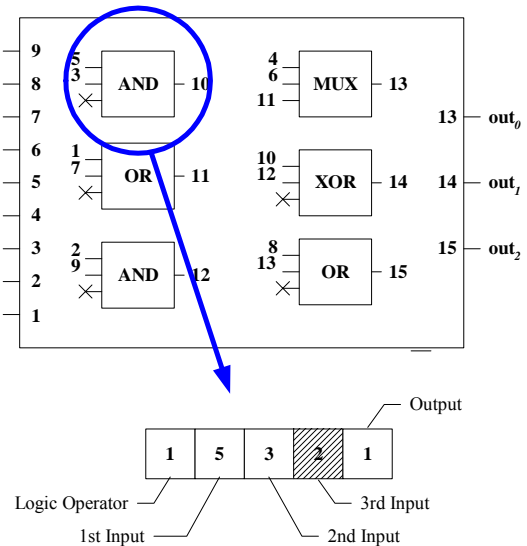

Fig. 9 Phenotype and genotype of behavior coordinator with logic operator.

3.3 User control mode

In the UCM, the user operates the robot directly based on the information that can be recognized by a blind person, such as auditory information. The robot provides the user with auditory information as converting visual information that is obtained by sensors into sound. The blind user receives the cane’s obstacle information and the cane benefits from the user’s flexible decision-making capabilities and his/her tactile and auditory information processing capabilities.

The user can point the active sensing unit of the robotic cane to user’s viewing direction. The active sensing unit of “RoJi” can track the user’s head movements by utilizing a gyrosopic sensor attached to user’s head. The robotic cane provides the user with auditory information as converting visual information, which is obtained by sensors, into sound. Also, speakers carry alarm sounds to alert the user.

User can recognize the distance and the direction of the obstacles combining the gyroscope/audio information from the cane and the auditory/tactile information from the user. Once

the navigation path is determined, the user can control the robotic cane by pressing the buttons on the interface panel.

4. NAVIGATION

Fig. 10 shows two autonomous operations of the robotic cane for avoiding two obstacles and guiding the user to a safe path when the user command is “Go Straight” and “Turn Left.” Two cubic objects are 21 cm (L) × 30 cm (W) × 25 cm (H) and 60 cm (L) × 20 cm (W) × 60 cm (H). In both cases, the robotic cane avoided these obstacles and returned to the original course of the user.

Fig. 11 shows two operations of the robotic cane for avoiding the complicated and the unexpected dynamic obstacles, and guiding the user to a safe path. In the first navigation experiment, the cane navigates around the chair in shallow and complicated shapes. In the second navigation experiment, the robotic cane avoided the sudden approaches of human pedestrians and returned to the original course of the user.

5. SUMMARY

A human robot interactive system was explored. Based on interactive technology, a robotic cane, “RoJi,” is proposed for blind or visually impaired travelers to navigate safely and quickly among obstacles and other hazards faced by blind pedestrians. Unique features of our robotic cane include an active sensing unit, antennas for contact sensing, powered wheels, and a customized-off-the-shelf (COTS) design.

Our robotic cane is operated based on a shared control approach, which contains the robot control mode (RCM) and the user control mode (UCM). The RCM is implemented by a lookup table and a heuristic logic operator. As the number of behavior increases and the system becomes more complicated, it will become difficult to find an appropriate coordinator for behavior arbitration. We are currently investigating an easy way to evolve coordinator’s elements based on an evolutionary engineering approach [27-34]. The UCM is implemented by user’s heuristic decision-making capabilities. The UCM allows the cane and the user to share geometric information about their environment and navigate following the user’s operation.

ACKNOWLEDGMENTS

This work was supported by grant No. R01-2001-000-00507-0 from the Korea Science & Engineering Foundation.

REFERENCES

- [1] I. Shim, “Interactive robotic cane,” Master Thesis, Pusan National University, Pusan, Korea, 2003.
- [2] P. Aigner and B. McCarragher, “Shared control framework applied to a robotic aid for the blind,” *IEEE Control Systems Magazine*, Vol. 19, No. 2, pp. 40-46, April 1999.
- [3] G. Lacey and K. Dawson-Howe, “The application of robotics to a mobility aid for the elderly blind,” *Robotics and Autonomous Systems*, Vol. 23, pp. 245-252, 1999.
- [4] J. Yoon, “Interactive technology as a man-machine interface,” *Monthly Magazine of Automatic Control & Instrumentation*, pp. 2-9, May 2001.



Fig. 10 Navigation of “RoJi” under static obstacles.



(a) Complicated obstacles



(b) Dynamic obstacles

Fig. 11 Navigation of “RoJi” under special obstacles.

- [5] J. Yoon, I. Hwang and S. Chang, “Metatechnology: Correspondence of the arts, sciences, technology and humans,” *International Journal of the Korean Society Precision Engineering*, Vol. 1, No. 1, pp. 71-78, June 2000.
- [6] J. Yoon and I. Hwang, “Interactivity in technology and art,” *Proceedings of the 15th Korea Automatic Control*

- Conference, Yongin, Korea, October 19-20, 2000.
- [7] J. Yoon, "Evolutionary robotics based on interactive technology," *Proceedings of 15th Korea Automatic Control Conference*, Yongin, Korea, October 17-18, 2000.
- [8] S. Shoval, I. Ulrich and J. Borenstein, "NavBelt and the GuideCane," *IEEE Robotics and Automation Magazine*, Vol. 10, No. 1, pp. 9-20, March 2003.
- [9] I. Shim, H. Park and J. Yoon, "Robotic cane for blind travelers," *Proceedings of the 2nd Workshop on Human-friendly Welfare Robotic Systems*, KAIST, Taejon, Korea, pp. 154-161, January 15-16, 2001.
- [10] I. Shim and J. Yoon, "Interactive robotic cane," *Proceedings of the 2002 Spring Annual Meeting of Korean Society of Precision Engineering*, pp. 338-341, May 17-18, 2002.
- [11] I. Shim and J. Yoon, "Robotic cane based on interactive technology," *Proceedings of the 2002 FIRA Robot World Congress*, Korea Robot Soccer Association, Vol. 1, No. 1, COEX, Seoul, Korea, pp. 581-586, May 26-29, 2002.
- [12] I. Shim and J. Yoon, "A robotic cane based on interactive technology," *Proceedings of the 4th Asian Control Conference*, Singapore International Conference & Exhibition Centre (SICEC), Singapore, September 25-27, pp. 156-161, 2002.
- [13] I. Shim and J. Yoon, "A robotic cane based on Interactive Technology," *2002 International Conference on Industrial Electronics, Control and Instrumentation (IECON-2002)*, Melia Lebreros Hotel, Sevilla, Spain, November 5-8, 2002.
- [14] COMFILE Technology, *PICBASIC2000 DATA BOOK*, COMFILE Technology, Seoul, 2000.
- [15] U. Nehmzow, *Mobile Robotics: A Practical Introduction*, Springer-Verlag, Berlin, 2000.
- [16] M. Kaneko, N. Kanayama and T. Tsuji, "Active antenna for contact sensing," *IEEE Transactions on Robotics and Automation*, Vol. 14, No. 2, pp. 278-291, April 1998.
- [17] muRata, "Piezoelectric Vibrating Gyroscopes: Gyrostar[®] ENV," Available http://www.avnet.se/avnet_times/september96/murata.html, 1996.
- [18] I. Shim and J. Yoon, "Cooperative behavior control for robotic cane based on interactive technology," *Proceedings of 2002 Joint Symposium of Control & Instrumentation, Automation and Robotics Research Groups*, Dankuk University, Chonan, pp. 130-134, April 27, 2002.
- [19] I. Shim and J. Yoon, "Shared behavior control for robotic cane based on interactive technology," *Proceedings of the 2002 FIRA Robot World Congress*, Korea Robot Soccer Association, Vol. 1, No. 1, COEX, Seoul, Korea, pp. 299-304, May 26-29, 2002.
- [20] I. Shim and J. Yoon, "Shared behavior control for a robotic cane based on interactive technology," *Proceedings of the 4th Asian Control Conference*, Singapore International Conference & Exhibition Centre (SICEC), Singapore, pp. 1718-1723, September 25-27, 2002.
- [21] I. Shim and J. Yoon, "An interactive robotic cane for blind travelers," *Proceedings of the 2002 International Conference on Control, Automation and Systems (ICCAS2002)*, pp. 2391-2396, Muju, October 16-19, 2002.
- [22] I. Shim and J. Yoon, "Shared behavior control for robotic cane based on interactive technology," *2002 International Conference on Industrial Electronics, Control and Instrumentation (IECON-2002)*, Melia Lebreros Hotel, Sevilla, Spain, November 5-8, 2002.
- [23] I. Shim and J. Yoon, "A human robot interactive system "RoJi"," *Proceedings of the 2003 IEEE/ASME International Conference on Advanced Intelligent Mechatronics (AIM2003)*, Vol. 2, pp. 723-728, Kobe, July 20-24, 2003.
- [24] R. Arkin, *Behavior-based Robotics*, The MIT Press, Cambridge, 1998.
- [25] I. Shim and J. Yoon, "Evolution of a robotic cane based on interactive technology," *Joint 1st International Conference on Soft Computing and Intelligent Systems (International Session of 18th SOFT Fuzzy Systems Symposium) and 3rd International Symposium on Advanced Intelligent Systems (SCIS & ISIS)*, The Auditorium of AIST, Tsukuba, Japan, October 21-25, 2002.
- [26] M. Negnevitsky, *Artificial Intelligence: A Guide to Intelligent Systems*, Addison-Wesley, San Francisco, 2002.
- [27] S. Nolfi and D. Floreano, *Evolutionary Robotics*, The MIT Press, Cambridge, 2000.
- [28] I. Shim and J. Yoon, "Evolutionary learning of mobile robot behaviors," *Proceedings of KFIS Fall Conference 2002*, Vol. 12, No. 2, pp. 207-210, December 7, 2002.
- [29] J. Lee, I. Shim and J. Yoon, "Realtime evolutionary learning of mobile robot behaviors," *Proceedings of the 2003 Spring Annual Meeting of Korean Society of Mechanical Engineering*, Korea Maritime University, Pusan, Korea, May 24-25, 2003.
- [30] H. Son and J. Yoon, "Evolving neural network for realtime learning control," *Proceedings of 15th Korea Automatic Control Conference*, Yongin, Korea, October 19-20, 2000.
- [31] S. Han and J. Yoon, "Action selections for an autonomous mobile robot by artificial immune network," *Proceedings of 15th Korea Automatic Control Conference*, Yongin, October 19-20, 2000.
- [32] R. Bonasso, D. Kortenkamp and R. Murphy, "Mobile Robots: A Proving Ground for Artificial Intelligence," *Artificial Intelligence and Mobile Robots*, The MIT Press, Menlo Park, pp. 3-18, 1998.
- [33] J. Liu and J. Wu, *Multi-Agent Robotic System*, CRC, New York, 2001.
- [34] D. Floreano and F. Mondada, "Hardware solutions for evolutionary robotics," *Evolutionary Robotics: First European Workshop*, P. Husbands and J.-A. Meyer eds., Springer-Verlag, Berlin, pp. 137-151, April 1998.
- [35] F. Mondada and D. Floreano, "Evolution and mobile autonomous robotics," *Towards Evolvable Hardware: The Evolutionary Engineering Approach*, Springer-Verlag, Berlin, pp. 221-249, 1999.
- [36] M. Sipper and E. Ronald, "A new species of hardware," *IEEE Spectrum*, pp. 59-64, March 2000.
- [37] R. Watson, S. Ficici and J. Pollack, "Embodied evolution: embodying an evolutionary algorithm in a population of robots," *Proceedings of the 1999 Congress on Evolutionary Computation*, Vol. 1, pp. 335-342, 1999.
- [38] A. Ishiguro, Y. Watanabe and Y. Uchikawa, "An immunological approach to dynamic behavior control for autonomous mobile robots," *Proceedings of the IEEE International Conference on Intelligent Robots and Systems*, Vol. 1, pp. 495-500, 1995.