

Testbed Development for Home Automation System using Bluetooth Wireless Network

K. Y. Lee* and J. W. Choi**

*School of Mechanical Engineering, Pusan National University, Pusan 609-735, Korea
(Tel: +82-51-510-3203; Fax: +82-51-514-0685; Email:advance@pusan.ac.kr)

**School of Mechanical Engineering and Research Institute of Mechanical Technology
Pusan National University, Pusan 609-735, Korea
(Tel: +82-51-510-2470; Fax: +82-51-514-0685; Email:choijw@pusan.ac.kr)

Abstract: Recently the idea of a home automation has been an important issue in many publications and home appliances companies. Home automation is a house or living environment that contains the technology to allow devices and systems to be controlled automatically. Remote and local control are useful to keep home comfortable and to support the elderly and the disabled people. In this paper, we discuss possible developments of Bluetooth wireless technologies and describe the hardware for devices and software for the considerations of a home automation system. Finally, we have validated the testbed by simulating in the Bluetooth home network.

Keywords: Bluetooth, Home automation, Remote control, Wireless home network

1. Introduction

Bluetooth technology is capable of transmitting data and voice at half-duplex rates of up to 1 Mbps without the use of cables between portable and fixed electronic devices. Home automation is one of the major applications of Bluetooth technology. The core technology of home automation is communicating and controlling automatically with each device and sensor in Bluetooth based on home network. Bluetooth network attempts to provide significant advantages over the other data transfer technologies, such as IrDA, Home RF, and Wireless LAN[1]. By using Bluetooth wireless home network, a home network system can be installed with a low cost and it is simple to implement in an existing home[2]. Bluetooth was designed primarily as a cable replacement technology for consumer electronic devices and data communication that uses short-range radio links to operate in the 2.4 GHz. The capability of Bluetooth and limits connectivity is quite suitable for home wireless networking environment[3]. We propose a home automation system based on Bluetooth home network technology as shown in Fig. 1.

Home appliances consist of many devices interconnected different ways. Sensor modules communicate between a measured sensor value and actuators with communicating data

packet collection units (I/O or a command). They basically communicate with an interface board attached Bluetooth through the PC. The device attached Bluetooth can be controlled both manually via the local switches and remotely via the server Bluetooth. The controller interface supports the browsing, the detection of network devices, context structures, and the user can interact with individual devices on the Bluetooth home network[4]. The hardware interface is used to access a local home automation network from a standard desktop PC with attached hardware for device modules and Bluetooth module. It can provide access and control services to the home network from any computer with an internet connection[5].

The primary objective of this study is to develop a remote control system over the Bluetooth home network in the home area. Simulations for controlling temperature in the Bluetooth home network are performed. In addition, the software program is developed using the visual C++ language. We also show how to operate between the server PC controller and the several client devices through the remote monitoring and controlling.

2. Bluetooth Home Network

2.1. Bluetooth

The Bluetooth radio interface operates in the unlicensed ISM (Industrial, Scientific and Medical) band starting at 2.402 GHz and ending at 2.483 GHz in the USA, and Europe. A Bluetooth module supports both point to point and point to multi-point connections. It provides the physical layer and a low-level communication protocol. Bluetooth uses a quick frequency-hopping (1600 hops per second) packet-switched protocol in order to minimize interference with other products that use the ISM band. Short data packets maximize throughput during interference. A TDM (Time Division Multiplexing) technique divides the channel into 625 μs slots. Transmission occurs in packets that occupy an odd number of slots (up to 5). Each packet is transmitted on a differ-

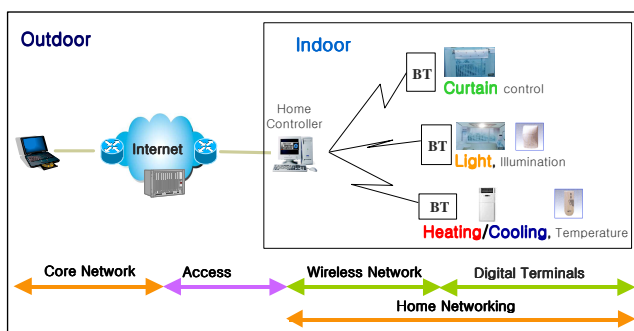

Fig. 1. Bluetooth based home network architecture

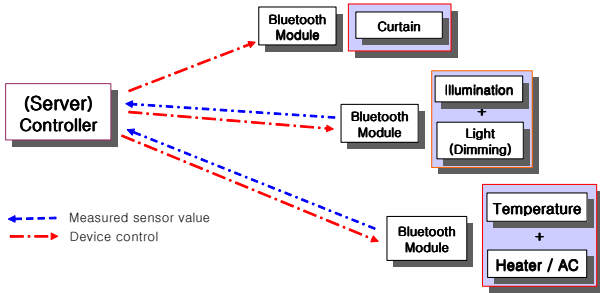

Fig. 2. Hardware configuration for the Bluetooth network

ent hop frequency with a maximum frequency hopping rate of 1600 *hops/s*. Up to 8 devices can share a piconet which has one master with all the others becoming slaves. Multiple piconet can exist across an area, creating a “scatternet” multiple independent and non-synchronized piconets form a scatternet. Each piconet is identified by a different frequency hopping sequence. All users participating on the same piconet are synchronized to this hopping sequence. When a new device is sensed by the piconet, that device must respond to an interrogation that provides access-level security. Hardware encryption is also offered. Typically, connections can be made up to 10 meters however separations of up to 100 meters can be achieved with an optional amplifier to boost the power level. Power consumption is low, 0.3 *mA* in standby and up to 30 *mA* during data transfer. The power level is adaptable in order to minimize interference. The first generation of Bluetooth offers a gross data rate of up to 1 *Mbps*. The 1 *Mbps* bandwidth is split into three 64 *kbps* channels for voice with the rest supporting packet data. One to one connections allow a maximum data rate of 721 *kbps*[6]. Bluetooth network consists of sensors and devices as shown in Fig. 2. The controller *i.e.*, server Bluetooth commands a device module such as a curtain, lighting, heater and air-conditioner. The sensor module transmits to server a measured sensor value as a sampling time. Each Bluetooth is connected with a integrated device and sensor module. This method is useful to increase a Bluetooth communication compare with each sensors and devices attached each Bluetooth module. It needs a less Bluetooth module to control many devices.

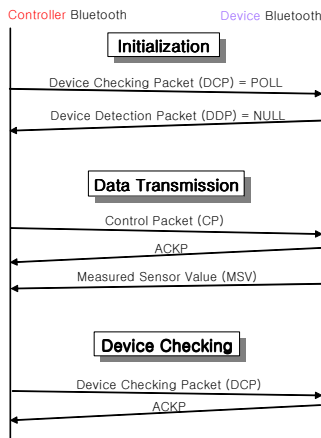

Fig. 3. Transformation diagram of Bluetooth module

2.2. Bluetooth connections

There are several steps to establish Bluetooth network as following Fig. 3. On initialization, the controller Bluetooth sends DCP (Device Checking Packet) to each device Bluetooth. Device Bluetooth scans a server Bluetooth and sends a DDP (Device Detection Packet) to the controller Bluetooth. The controller Bluetooth sends an ACKP (Acknowledgment Packet) or NACK (Non-Acknowledgment Packet). On device checking, controller Bluetooth sends a DCP to device Bluetooth to check. If server Bluetooth does not receive an acknowledgment from the device Bluetooth, the controller Bluetooth assumes that the device Bluetooth is not connected or not working. On data transmission, the controller Bluetooth sends a CP (Control Packet) to the device Bluetooth. If the device Bluetooth receives a CP, the device Bluetooth sends an acknowledgment and updates a MSV (Measured Sensor Value). They are communicating between the controller Bluetooth and the device Bluetooth repeatedly[7].

3. Hardware Implementation

The device circuit consists of PC interface, sensor circuit and PWM (Pulse Width Modulation) circuit. Integrated sensor circuit and PWM circuit are in the interface board. The Bluetooth of implemented hardware communicates with controller and device shown in Fig. 4.

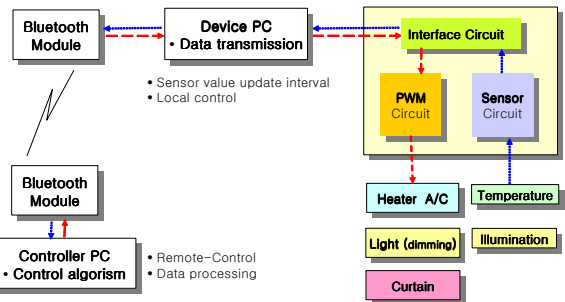

Fig. 4. Hardware configuration of sensors and devices

3.1. Interface board

The interface board for home automation systems is implemented through PC connection such as the parallel, serial, or USB port. The devices connect the interface board which is interfaced with the PC via a transceiver, and it transfers via the Bluetooth module. We explain the connection of the interface board through a parallel port. There are two types of parallel ports with different functions. EPP (Enhanced Parallel Port) mode supports high-speed external devices with 8 *bit* bidirectional data bus such as external hard disk and scanner. ECP (Extended Compatibility Port) mode supports a high-speed data transmit a printer with 8 *bit* bidirectional data bus. The transmission rate is 500 *Kbites/sec* up to 2 *Mbites/sec*. Therefore, the parallel port is enough to communicate with devices in home network. We use a ECP mode to implement a interface board.

3.2. Temperature sensor

The system consists of a temperature sensing circuit, which is used to keep track of the room temperature, and a heater

Table 1. Output data of temperature circuit

Temperature (°C)	LM35DZ (mV)	Amp output voltage (mV)	ADC output (bit)
0	0	0	0
1	10	40	2
2	20	80	4
⋮	⋮	⋮	⋮
99	990	3960	202
100	1000	4000	204

and air-conditioner control circuit which are used to regulate the room temperature. IC temperature sensor, LM35 generates the power with linear fashion. The temperature circuit is composed of VCVS (Voltage Controlled Voltage Source) type second order low pass filter and non-inverting amplifier to transmit an output voltage to A/D (Analog-Digital) converter. The rate of non-inverting amplification is computing as follows:

$$Output = 4 \times Input = \left(1 + \frac{30K}{10K}\right) \times Input \quad (1)$$

The non-inverting amplifier amplifies a minute sensor output signal which is transferred from second-order low pass filter to recognize in the A/D converter. The A/D converter has an 8 bit resolution. The resolution of 0~5 V is as follows:

$$\Delta V = \frac{5(V)}{255(bit)} = 19.61(mV/bit) \quad (2)$$

The output data of temperature circuit units were measured according to temperature is going up as shown in Table 1. We compute a temperature sensor value with proportional expression between standard temperature and A/D converter data.

3.3. Illumination sensor

The system module consists of an illumination sensing circuit, which is used to keep track of the indoor luminosity and a lighting control circuit which are used to regulate the room luminosity. The illumination sensor is able to keep a pleasant luminosity and to save a energy through lighting control. Cds cell is generally used as the illumination sensor. Cds cell is a variable resistor with varying resistor value when the light reaches to sensor. The output voltage of Cds cell is given by

$$V = iR_s = \frac{R_s}{R_L + R_s} V_{cc} \quad (3)$$

where V , V_{cc} , R_s , R_L , k and L are sensor output voltage, supply voltage, sensor resistor, load resistor, proportional constant and luminous intensity respectively. An electric current is as follows:

$$i = kVL^\gamma \quad (4)$$

where γ is a photo resistance index which has a value between 0.5 and 1. The resistance with $\gamma = 1$ can be obtained as follows:

$$R_s = \frac{1}{kL} = \frac{V}{i} \quad (5)$$

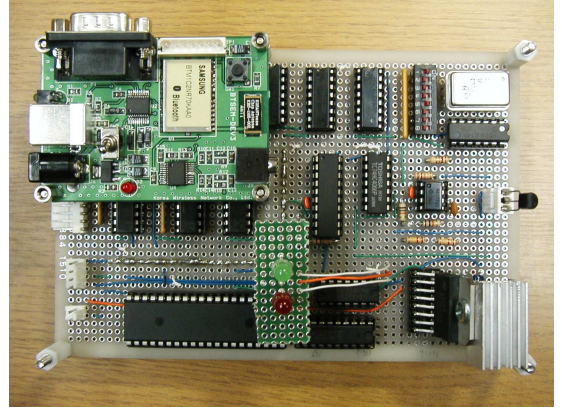

Fig. 5. Integrated module circuits

where R_s is inversely proportional to L (Luminous intensity). Luminous intensity is increasing as an illumination is getting bright and, R_s is diminishing. So, the programming computes a Lux value to revise a illumination sensor data as follows:

$$Lux = ((255 - M_v) \times 10)/128 \quad (6)$$

where M_v is the measured value of an illumination sensor data. Analog-digital converter is received a higher voltage as an illumination is getting dark. Illumination sensing circuit is designed to provide regular input impedance by voltage follower amplifier which has a function of buffer.

3.4. PWM module

The PWM technique is used in static power converters for output voltage and frequency control. It is used in motor drive and PWM synchronous rectification for unity power factor operation. A PWM is a method of controlling the amount of power to a load without having to dissipate any power in the load driver. The amount of power delivered to the load is proportional to the percentage of time that the load is switched on. The on-off switching is called PWM. In this paper, the PWM module is used the motor speed control and dimming system. A PWM module is implemented through PC interfaces with parallel port. PWM signals can be generated in a number of ways. There are several method Analogue method, Digital method, Discrete IC and Onboard Microcontroller. Digital method uses a special purpose hardware and software routine. In digital schemes, PWM patterns are calculated by the 8255A output data values using suitable algorithm. The digital method involves incrementing a counter and comparing the counter value with a pre-loaded register value. It is a digital version of the analog method. The integrated modules consist of PWM circuit, temperature sensor circuit and interface circuit which is included Bluetooth module as shown in Fig. 5.

4. Software Development

A home network program is developed by using visual C++ language. The proposed Bluetooth home network system is composed of remote controller interface program and device operating program. The software of controlling the Bluetooth module includes a set of instructions which are nec-

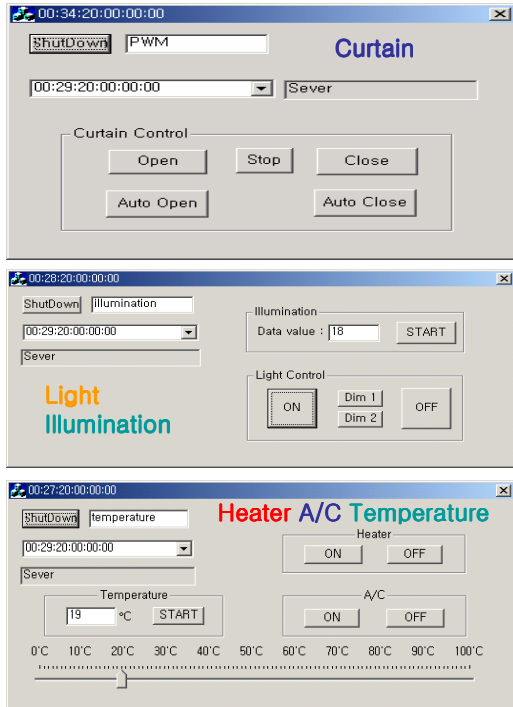

Fig. 6. Device direct controller interfaces

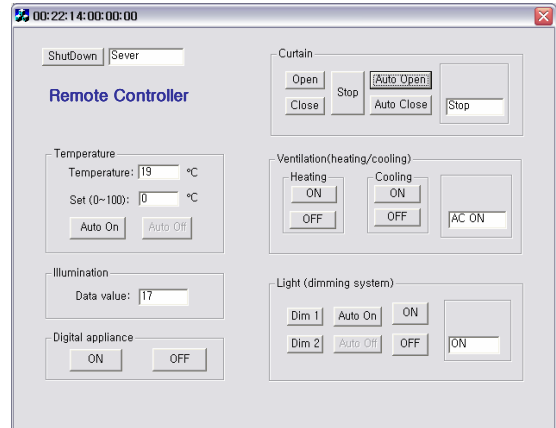

Fig. 7. Remote-controller interface

remote control and wireless communication. The controller interface is able to confirm that devices are operating well or not. It can control home devices and monitor device state when the user is in the outdoors.

5. Testbed development and experiments

The experimental set up of a testbed device module with a fan and temperature sensor is shown in Fig. 8. The fan is controlled with a variable speed via PWM circuit. It shows that heater and A/C system are operating well according to temperature is changing in Fig. 9. The heater and A/C control circuits are used to keep track of the room temperature.

essary to initialize the Bluetooth device after power on or reset, configure it to identify itself on Bluetooth piconet, to accept the connection request from the controller, and to establish the connection the subsequently exchange of data. The Bluetooth home network is organized when the device Bluetooth modules are connected with controller Bluetooth.

4.1. Device programming

The device operating interface program connected with controller Bluetooth is a different interface as a device type. Fig. 6 demonstrates the device direct controller interface scene. The device Bluetooth transmits a measured temperature data to the controller Bluetooth, and receives a command vice versa. First device operating interface has a curtain control which consists of open, close and auto mode. Second device operating interface has a dimming system and illumination sensor. The last device operating interface consists of heater and A/C on-off and temperature sensor. The measured temperature sensor value and illumination sensor value can be monitored in the controller operating interface side.

4.2. Controller programming

The remote-controller user interface consists of devices control part and sensor monitoring part as shown in Fig. 7. The Controller PC receives a measured temperature data, and illumination sensor data from the device sensor module at every sampling time. In addition, it is operating a command packet according to the algorithm. The sensor data and state packet from device are updated at every 3 sec. The dimming system and heating/cooling system are operating with a illumination sensor information and a temperature sensor information. In addition, it is able to control remotely when an external PC access to the home server PC via internet connection. Reliability is very important things in case of



Fig. 8. Testbed for Heater A/C and temperature

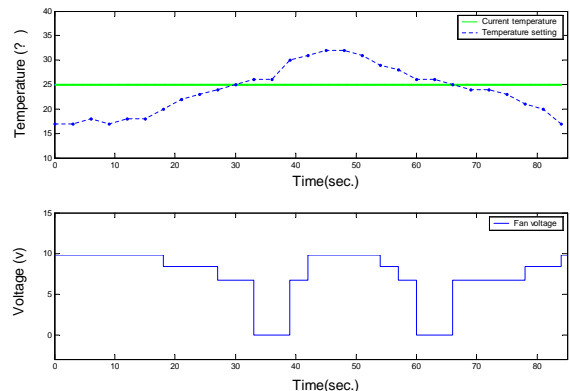

Fig. 9. Temperature and device operation



Fig. 10. Testbed for lighting and illumination

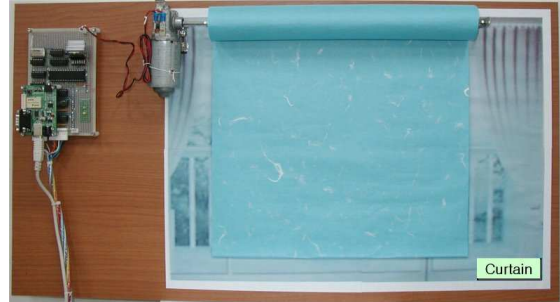

Fig. 12. Testbed for curtain control

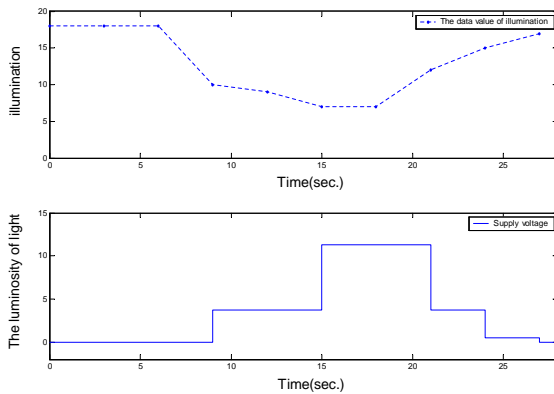

Fig. 11. Illumination and luminosity of light operation

The testbed for dimming system consists of illumination sensor and lighting as shown in Fig. 10. It shows that luminosity of light is controlled by using the illumination sensor information in Fig. 11. The testbed for curtain control system has a DC motor which is operating a curtain open/close in Fig. 12.

6. Conclusions

In this paper, a home automation system based on a Bluetooth wireless technology is proposed. The proposed Bluetooth home network is designed for monitoring and remote control of different appliances connected over Bluetooth network in a home environment. The developed Bluetooth home network system includes emulation programs of each device and a home controller program. The Bluetooth network system has been simulated to be operating by developing sensor module and device control system. The usefulness of the proposed method is proven through simulations and experiments using the developed testbed device modules.

References

- [1] D. Valtchev, and I. Frankov, "Service Gateway Architecture for a Smart Home," *IEEE Communications Magazine*, Vol. 40, No. 4, pp. 126-132, 2002.
- [2] R. Shorey, and B. A. Miller, "The Bluetooth Technology: Merits and Limitations," *IEEE International Conference on Personal Wireless Communications*, pp. 80-84, 2000.
- [3] K. V. S. S. S. S. Sairam, N. Gunasekaran, and S. R. Redd, "Bluetooth in Wireless Communication," *IEEE Communications Magazine*, Vol. 40, No. 6, pp. 90-96, 2002.
- [4] P. M. Corcoran, and J. Desbonnet, "Browser-Style Interfaces to a Home Automation Network," *Proceedings of the 10th Mediterranean Electrotechnical Conference*, pp. 298-301, 2000.
- [5] R. J. C. Nunes, and J. C. M. Delgado, "An Internet Application for Home Automation," *IEEE Transactions on Consumer Electronics*, Vol. 43, No. 4, pp. 1063-1069, November 1997.
- [6] D. Valtchev, and I. Frankov, "Bluetooth Wireless Technology in the Home," *Electronics and Communication Engineering Journal*, Vol. 13, No. 5, pp. 195-203, 2001.
- [7] N. Sriskanthan, F. Tan, and A. Karande, "Bluetooth Based Home Automation System," *Microprocessors and Microsystems*, Vol. 26, No. 6, pp. 281-289, 2002.