

Immune Algorithms Based 2-DOF Controller Design and Tuning For Power Stabilizer

Dong Hwa Kim, Jin Ill Park

Dept. of Instrumentation and Control Eng., Hanbat National University,
16-1 San Duckmyong-Dong Yuseong-Gu, Daejeon City, Korea, 305-719.

E-mail: kimdh@hanbat.ac.kr

Tel: +82-42-821-1170, Fax: +82-821-1164

Abstract – In this paper the structure of 2-DOF controller based on artificial immune network algorithms has been suggested for nonlinear system. Up to present time, a number of structures of the 2-DOF controllers are considered as 2-DOF (2-Degrees Of Freedom) control functions. However, a general view is provided that they are the special cases of either the state feedback or the modification of PID controllers. On the other hand, the immune network system possesses a self organizing and distributed memory, also it has an adaptive function by feed back law to its external environment and allows a PDP (parallel distributed processing) network to complete patterns against the environmental situation, since antibody recognizes specific antigens which are the foreign substances that invade living creatures. Therefore, it can provide optimal solution to external environment. Simulation results by immune based 2-DOF controller reveal that immune algorithm is an effective approach to search for 2-DOF controller.

I. INTRODUCTION

In recently years, combined learning-based artificial intelligence (AI) such as neural network, fuzzy control, genetic algorithm, immune network structures have been interested in studying much attention for their robustness and flexibility against a dynamically changing system or complex system, since conventional artificial intelligent systems based on a functional decomposition, leading to a so-called "sense-model-plan-action" cycle have been criticized on many grounds over the last decade [1] – [3].

They are used extensively in industry in such diverse applications as fault prediction, fault diagnosis, supervisory control, energy management, production management, software engineering, and among others [3].

It is a challenge in control and computer communities to explore novel control strategies and philosophies for complex industrial processes. In complex processes in practice, the range of uncertainty may be substantially larger than can be tolerated by crisp algorithms of adaptive and robust control. What are known as "intelligent" control techniques [6] are useful here.

The application of intelligent system technologies in industrial control has been developing into an emerging technology, so-called 'Industrial intelligent control'. This technology is highly multi-disciplinary and rooted in systems control, operations research, artificial intelligence,

information and signal processing, computer software and production background [8-9].

Chronologically, fuzzy logic was the first technique of intelligent systems. Neural, neuro-fuzzy and evolutionary system and their derivatives followed later. Each technique is offering new possibilities and making intelligent system even more versatile and applicable in an ever-increasing range of industrial applications.

Over the past decade or so, significant advances have been made in two distinct technological area: fuzzy logic (FL) and neural networks (NNs) [1] – [3]. There has been considerable interest in the past few years in exploring the applications of fuzzy neural network (FNN) systems, which combine the capability of fuzzy reasoning to handle uncertain information and the capability of artificial networks to learn from processes, to deal with nonlinearities and uncertainties of control systems.

On the other hand, biological information processing systems such as human beings have many interesting functions and are expected to provide various feasible ideas to engineering fields, especially intelligent control or robotics [1] – [4]. Biological information in living organisms can be mainly classified into the following four systems: brain nervous, genetic system, endocrine system, and immune system. Among this system, brain nervous and genetic systems have already been applied to engineering fields by modeling as neural network and genetic algorithms [8], they have been widely used in various fields. However, Only a little attention has been paid to application of the other systems, not to mention their important characteristics and model. The purpose of this paper is to propose the use of artificial immune algorithms as implementation of 2-DOF (2-Degrees Of Freedom) control system [6] – [8].

2. IMMUNE ALGORITHMS FOR THE PID CONTROLLER

2.1 Feedback Control System By Immune Algorithm

The immune system is interested in data mining, control system application [6] – [10], intelligent system combined with fuzzy or neural network [5], a multi-agent system. It is characterized with a large number and composed of variety of components distributed throughout the body. Individual

actions of vast numbers of cells in immune system, and their interactions with even larger numbers of molecular mediators, determine the course of an infection. This distributed collection of agents protects organisms against a wide variety of attacks. It is important not only for learning to apply for control engineering, but also for understanding control of distributed systems in general.

The characteristics of Cell action are governed largely by molecular signals. Each cell represents on its surface an enormous number of receptors for a variety of different chemicals. These receptors bind to extracellular molecules, or molecules on the surfaces of other cells. Which subsets of receptors are bound determines whether cells die, divide, move, differentiate, or produce molecules for secretion or expression determines whether a cell is listening for a specific kind of information [8].

Intracellular signaling mechanisms connected to these receptors determine the response to each such signal. In addition, interactions between intracellular signaling pathways cause the cell's response to be a function of combinations of external signals.

Some paper explained how certain kinds of molecular signals can provide feedback to tune the immune system response. In addition to eliminating an invading pathogen, an immune response often causes incidental damage to the host. Recruitment of immune system effectors to an infected area results in inflammation, with negative effects on blood circulation and local tissue integrity. Toxins required to kill certain pathogens may also damage host cells.

Antibody in the immune system should kill dangerous antigens but should not harm the host. They showed how chemical signals indicating when antigens were being killed and when host cells were being damaged could be used to adjust the response so as to minimize both kinds of damage.

Here, we expand on this earlier work by using genetic algorithms to explore what forms of feedback information are most useful in the model system.

One of modeling the immune system is to derive a set of differential equations that describe the changes in concentrations of the relevant cell and molecule types over time. These equations describe the average behavior of the system, assuming ideal mixing.

In Fig. 2, the basic components of the biological immune system are macrophages, antibodies, and B-cell. B-cell is the cells maturing in bone marrow, which

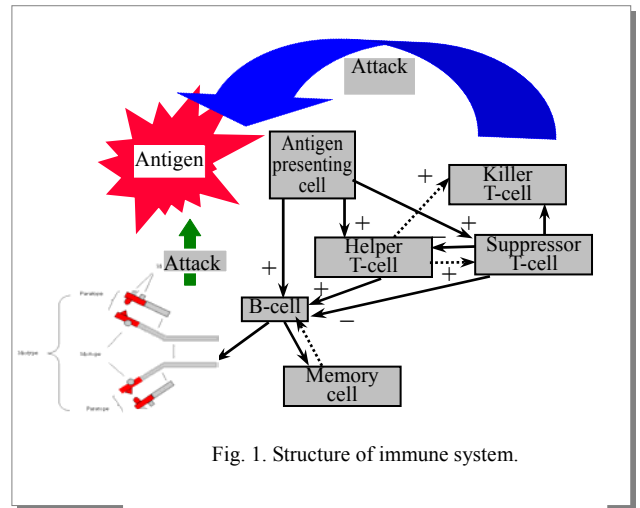

collectively form what is known as the immune network. Roughly 10^7 distinct types of B-cell are contained in a human body, each of which has a distinct molecular structure and produces "Y" shaped antibodies from its surfaces [4].

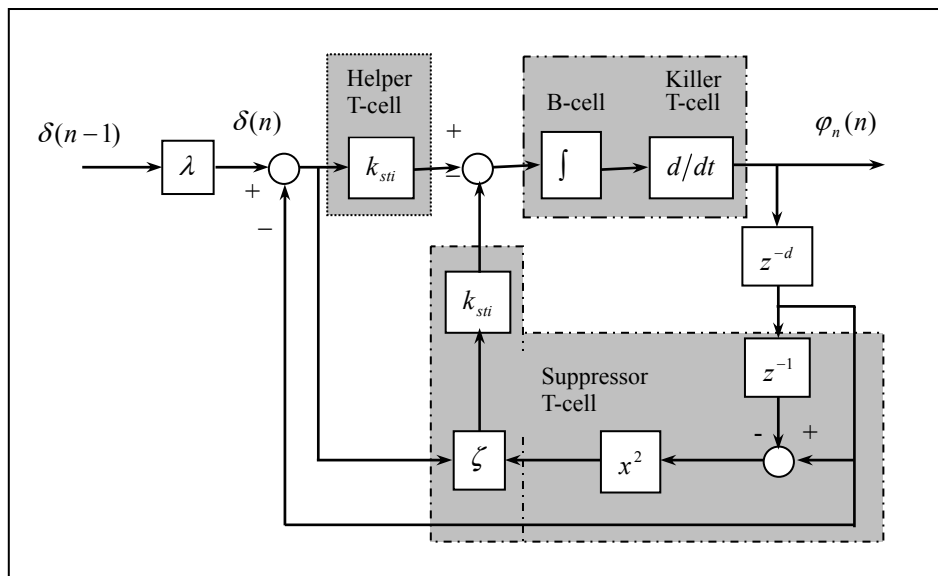

Fig.2. Block diagram for immune based feedback system.

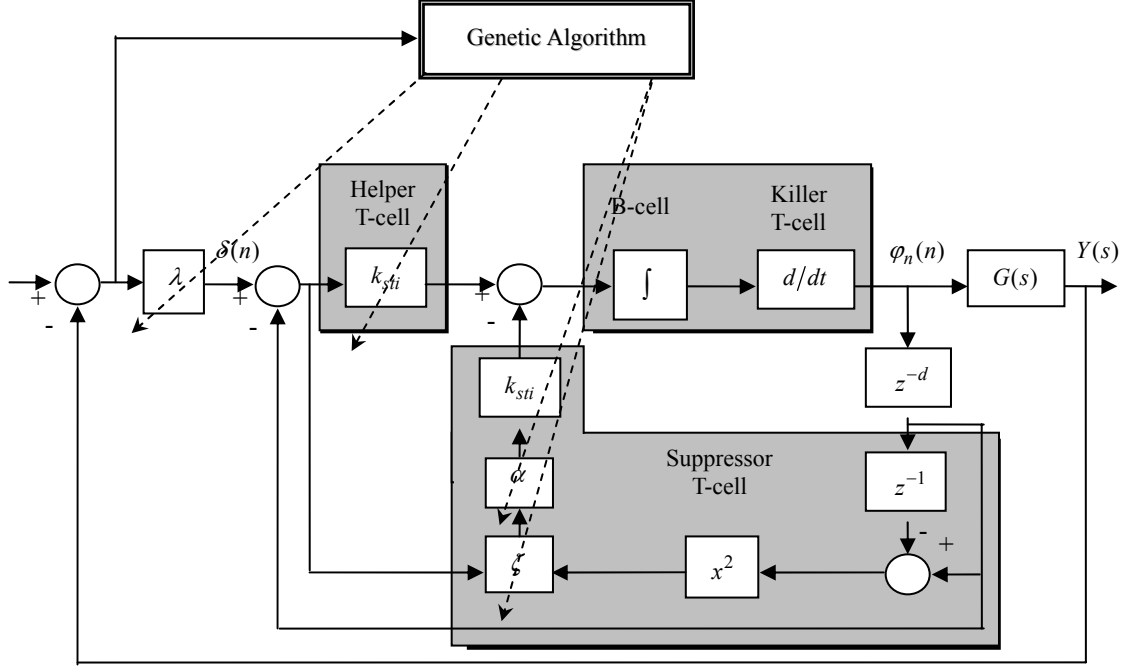

Fig. 3. Block diagram of 2-DOF Controller by immune network with genetic algorithm tuning.

When a B cell encounters an antigen, an artificial immune response is elicited, which causes the antibody matches the antigen sufficiently well, its B cell becomes stimulated and can produce mutated clones which are incorporated into the immune network. That is, the antibody recognizes specific antigens which are the foreign substances that invade living creatures, and this reaction is often likened to a key and keyhole relationship [7]. In immune algorithm, the response antibody is given by:

$$\delta(n) = \lambda\delta(n-1) - \varphi_n(n-d), \quad (1)$$

where, $\delta(n)$ is the number of antibody in n-generations, λ is the multiplication rate of antigen, $\varphi_n(n)$ is the product rate of killer-T cell in n-generation, d is delay time from killer-T cell to action.

Total stimulation of helper T by antibody stimulation $S_{tb}^{helper}(n)$ is defined by:

$$S_{tb}^{helper}(n) = k_{sti}\delta(n), \quad (2)$$

where k_{sti} is constant and decide stimulation level ($k_{sti} > 0$).

Suppression action is decided as

$$S_{tb}^{sup} = k_{sup}[\varphi_n(n-d) - \varphi_n(n-d-1)]^2 \delta(n), \quad (3)$$

where, k_{sup} is constant for deciding suppression level ($k_{sup} > 0$).

Finally, stimulation of B-cell is given by

$$S_{sti}^b = S_{tb}^{helper}(n) - S_{tb}^{sup}(n). \quad (4)$$

Since B-cell is stimulated from external condition, the activation of B-cell is obtained by integrating S_{sti}^b . The number of killer T, $\varphi_n(n)$ is obtained by integrating B-cell and is given as:

$$\begin{aligned} \varphi_n(n) &= \frac{d}{dt} \int S_{sti}^b dt, \\ &= k_{sti}\delta(n) - k_{sup}[\varphi_n(n-1) - \varphi_n(n-1-d)]^2 - \delta(n), \\ &= k_{sti} \left[1 - \zeta \{ \varphi_n(n-d) - \varphi_n(n-d-1) \}^2 \right] \delta(n), \end{aligned} \quad (5)$$

where, $\zeta = k_{sup}/k_{sti}$. In equation (5), when the number of antibody $\delta(n)$ is error, the number of killer T $\varphi_n(n)$ is control input the control scheme is feedback control system with controller gain k_{sti} , ζ . Therefore, we can the controller with the 2-DOF function through stimulation by k_{sti} and suppression by ζ .

2.2 Tuning By Genetic Algorithm

This paper used genetic algorithm to tune parameters of 2-DOF controller based on immune algorithm as Fig. 3. In Fig. 3, $R(s)$ is set-point, $Y(s)$ is the output of plant. The error(s) of between $R(s)$ and $Y(s)$ is to be antigen.

3. SIMULATION AND DISCUSSION

In this paper, we use stabilizer of power plant given as Fig. 4 [14].

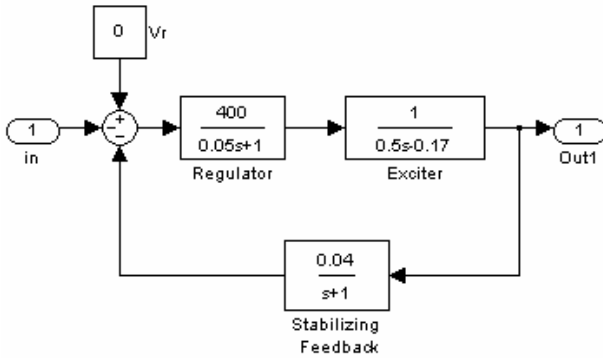

Fig. 4. Block diagram of stabilizer.

Where, parameters are

$$\text{Regulator} = \frac{K_a}{1 + \tau_{AS}}, \quad \text{Exciter} = \frac{1}{K_E + \tau_{ES}},$$

$$\text{Stabilizer} = \frac{K_F}{1 + \tau_{FS}},$$

$$K_a = 400, K_E = -0.17, K_F = 0.04, V_R = 1.1 \text{ pu}, \\ \tau_A = 0.05, \tau_E = 0.5, \tau_F = 1.0.$$

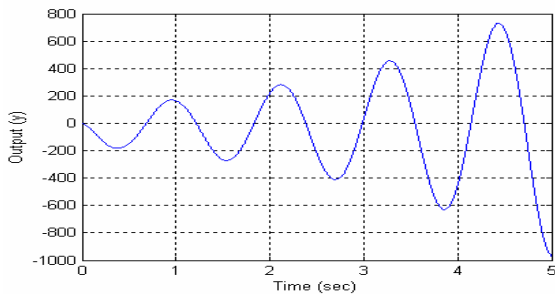

Fig. 4. Response of stabilizer without controller to step input.

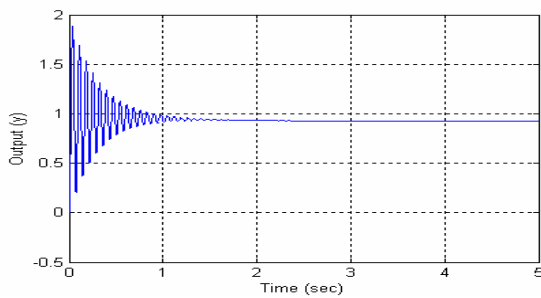

Fig. 5. Response of stabilizer to $\lambda, \alpha, k_{sti}, \zeta = 0.1 \sim 1$.

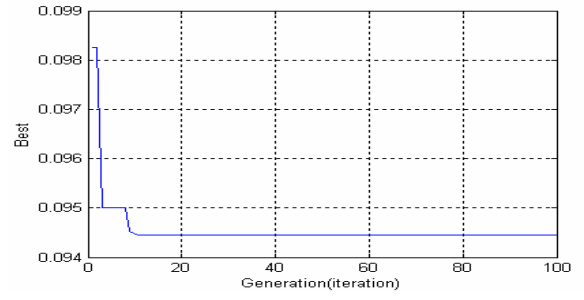

Fig. 6. Relationship fitness and generation for initial value range $\lambda, \alpha, k_{sti}, \zeta = 0.1 \sim 1$.

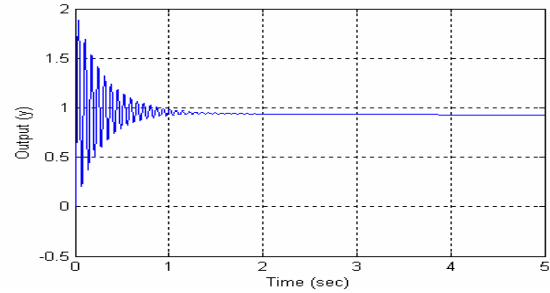

Fig. 7. Response of stabilizer to $\lambda, \alpha, k_{sti}, \zeta = 0.01 \sim 1$.

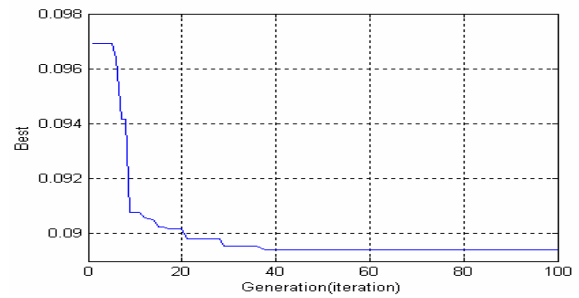

Fig. 8. Relationship fitness and generation for initial value range $\lambda, \alpha, k_{sti}, \zeta = 0.01 \sim 1$.

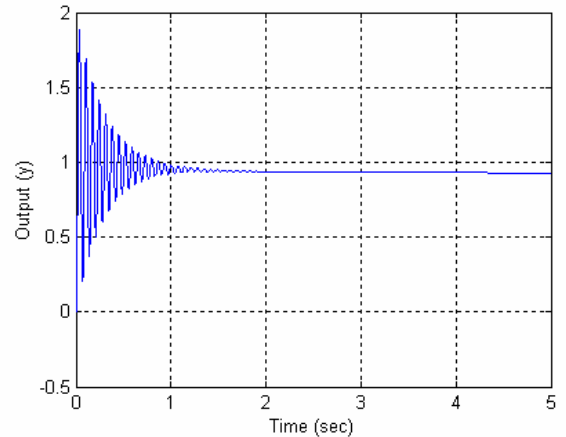

Fig. 9. Response of stabilizer to $\lambda, \alpha, k_{sti}, \zeta = 0.001 \sim 1$.

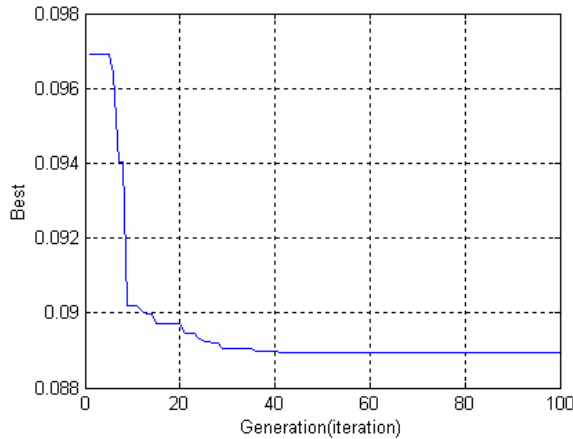

Fig. 10. Relationship fitness and generation for initial value range $\lambda, \alpha, k_{sti}, \zeta = 0.001 \sim 1$.

Figs 5-6 show the results of response of stabilizer and variation of fitness function to generation when the range of α, k_{sti}, ζ is 0.1~1 and Figs 7-8 show the results of response of stabilizer and variation of fitness function to generation when the range of α, k_{sti}, ζ is 0.01~1, respectively. In this simulation, fitness function is given by:

$$Fitness = \int_{t=0}^n |e| dt, \quad (7)$$

n : final time.

4. CONCLUSION

This paper suggested the feasibility design of 2-DOF controller by immune network algorithms and represented response to the variation of parameter in immune network. If this parameter is more verified in each case of plant, the results of simulation shows it can be used as the 2-DOF controller. Since the structure of feedback immune network is similar as a type of 2-DOF based on PID controller, it will be used for the nonlinear system if tuning problem is proven. It should be studied for stability and reliability on system through simulation and experiments to apply an actual plant.

REFERENCE

[1] Assilian and E.H. Mamdani, "An experiment in linguistic synthesis with fuzzy logic controllers," Int. J. Man-Machine Studies vol. 7, pp. 1-13, 1974.

[2] A. Homaifar and E. McCormick, Simultaneous design of membership functions and rule sets for fuzzy controllers using genetic algorithms, IEEE Trans. Fuzzy Systems vol. 3, pp. 129-139, 1995.

[3] R. Ketata, D. De Geest and A. Titli, "Fuzzy controller: design, evaluation, parallel and hierarchical combination with a PID controller," Fuzzy Sets and Systems, vol. 71, pp. 113-129, 1995.

[4] Yoshiteru Ishida, "The immune system as a prototype of autonomous decentralized systems: An over view,"

IEEE conference, pp. 85-92, 1997.

[5] D. H. Kim, "A application of intelligent control algorithms," Conference of ICASE, pp. 15-17, 1997. Seoul

[6] Dong Hwa Kim, "Intelligent tuning of a PID controller using a immune algorithm," Trans. KIEE, vol. 51-D, no.1, pp. 2002.

[7] Dong Hwa Kim. "Intelligent Tuning of the 2-DOF PID Controller on the DCS for Steam Temperature Control of Thermal Power Plant,"IEEE I&CPS, Savannah. May 5-10, 2002.

[8] Dong Hwa Kim. "Tuning of 2-DOF PID controller by immune algorithm," May 12-17, 2002, IEEE international conference on evolutionary computation, Hawaii.

[9] J. D. Farmer, N. H. Packard and A. S. Perelson, "The immune system, adaptation, and machine learning, Physica. D 22, pp.187-204, 1986.

[10] Dong Hwa Kim, "Auto-tuning of reference model based PID controller using immune algorithm," May 12-17, 2002, IEEE international conference on evolutionary computation, Hawaii.

[11] Assilian and E.H. Mamdani, An experiment in linguistic synthesis with fuzzy logic controllers, Int. J. Man-Machine Studies 7, 1-13, 1974.

[12] A. Homaifar and E. McCormick, Simultaneous design of membership functions and rule sets for fuzzy controllers using genetic algorithms, IEEE Trans. Fuzzy Systems 3, 129-139, 1995.

[13] R. Ketata, D. De Geest and A. Titli, Fuzzy controller: design, evaluation, parallel and hierarchical combination with a PID controller, Fuzzy Sets and Systems 71, 113-129, 1995.

[14] Adel Ben-Abdenour, Kwang Y.Lee, "A Decentralized Controller Design for a Power Plant Using Robust Local Controllers and Functional Mapping", IEEE Transactions on Energy Conversion, Vol. 11, No. 2, June 1996.