

## Study on Fault Diagnosis Method of Train Communication Network applied to the prototype Korean High Speed Train

Chang-Hee Cho\*, Min-Kook Park\*, Soon-Man Kwon\*, Yong-Ju Kim\*, and Sung-Shin Kim\*\*

\* Korea Electrotechnology Research Institute, Changwon, Korea

(Tel : +82-55-280-1473; E-mail: [chcho@keri.re.kr](mailto:chcho@keri.re.kr))

\*\*Department of Electrical Engineering, Pusan National University, Pusan, Korea

(Tel : +82-51-510-2366; E-mail: [sskim@pusan.ac.jp](mailto:sskim@pusan.ac.jp))

**Abstract:** The development project of Korean High Speed Train (KHST) was started in 1996. As a national research project, the KHST project aims for a development of the next generation prototype train that has a maximum speed of 350 km/h. The development process of prototype KHST including 7 vehicles was completed last year and currently the prototype train is on its way of test running over the test track with gradually increased speed. The prototype KHST uses the real time network called TCN (Train Communication Network) for exchanging information between various onboard control equipments. After 10 years of development and modification period, TCN was confirmed as international standard (IEC61375-1) for the electrical railway equipment train bus. In the prototype KHST, all major control devices are connected by TCN and exchange their information. Such devices include SCU (Supervisory Control Unit), ATC (Automatic Train Control), TCU (Traction Control Unit), and so forth. For each device that sends and receives data using TCN, a device has to find out whether TCN is in normal or failure state before its data exchange. And also a device must have a proper method of data validation that was received in a normal TCN state. This is a one of the major important factors for devices using network. Some misleading information can lead the entire system to a catastrophic condition. This paper briefly explains how TCN was implemented in the prototype KHST train, and also shows what kind of the fault diagnosis method was adopted for a fail safe operation of TCN system

**Keywords:** TCN, KHST, Network, Fail safe

### 1. INTRODUCTION

Recently, the high speed train is said to be the next generation of transportation. It has more comfortable access to downtown of city area than aerial transportation and has more efficient energy utilization using high speed and mass transportation. It also has the environmental advantage compare to other transportations that use fossil fuel as energy source.

The high speed train technology includes almost every modern technological fields including construction, signaling, structure, dynamics, design, control & instrumentation, and so forth. For the control system's point of view, controller can be divided into major 5 sub-systems. They are

- | Propulsion system
- | Braking system
- | Power system
- | Supervisory system
- | Auxiliary system

Those sub-systems contain several  $\mu$ -processor based digital controllers. And the connections among those are implemented by the network system.

The KHST uses the TCN as major network system of entire train set. It uses TCN to exchange information between equipments that work for the control and diagnosis of train. As the most of signals are exchanged using TCN, the performance characteristic of the control and diagnosis system is greatly affected by the performance characteristic of the TCN. And it also affects a large factor on the performance and safety of practical train operation.

Considering this importance of network, it is required to design, to simulate, and to operate the network system before we go into commercial operation.

### 2. TRAIN COMMUNICATION NETWORK

Finally, TCN was fixed as international standard in summer of 1999. (IEC 61375, Electric Railway Equipment – Train Communication Network) In Fig. 1, you can see the constitution of TCN. As in the illustration, TCN is a 2 level hierarchical network. One is a upper part of network that connects the entire train. This bus is called as WTB (Wire Train Bus). And the other is one is a lower part of the network that connects the equipments inside a vehicle. This bus is called as MVB (Multifunction Vehicle Bus).

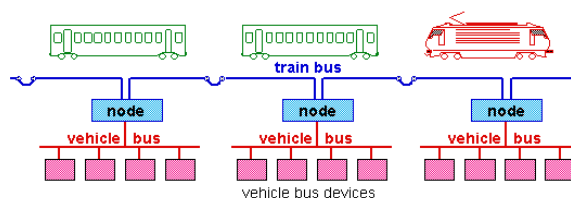

Fig. 1 Constitution of TCN

As a specialized network for railway application, TCN has following distinguished features.

- | Inauguration
- | Fritting
- | Real Time Network
- | Process and Message Data
- | Source Addressed Broadcast
- | Fault tolerant architecture

Inauguration is a function for WTB node. It is a function of automatic initialization of a train. The international train that frequently runs beyond the national boarder has a lot of chances to change its composition. Inauguration is initiated when the composition of train has changed. After the inauguration process, each WTB node knows her network

address, left/right direction, other vehicles information, and so forth.

And the fritting is another special function for WTB. This function prevents the contacts of train bus from oxidation by applying small dc currents through WTB wire.

And TCN is a real time network that gives a definite connection between equipment within a prescheduled time. Key of this real time feature is given by Source addressed broadcast scheme of the process data transmission. Source addressed broadcast is initiated by a bus master by sending a master frame over the network. When a bus master sends this frame to request transmission of certain variable as on prescheduled time table, a device that are to send the variable (Publisher) broadcasts a slave frame containing the variable. While, every device on the bus checks that slave frame, some devices that are designed to receive the variable (Subscribers) read the slave frame and copy it to their memory called the traffic store. While the process data is transmitted on the regular basis, the message data is transmitted on demand. It uses call/reply of the client/server concept, and each message packet is transmitted with the source and destination information.

TCN also has features for fault tolerant characteristics to increase the network availability. For example, the redundant concepts are used in bus medium (line) and bus administrator. And various software and hardware architecture exist for detect and recover from error. In addition to the features mentioned above, TCN has some specific features such like fritting, sink time supervision, check variables, train network management, and so forth.

- | Concentrated power traction
- | Improved articulatory bogie
- | Aluminum compound body
- | Induction motor
- | Frictional, regenerative, eddy Current Brake System
- | 11 or 20 variable composition

To achieve more speed than KTX, KHST provides more power than KTX. To make more power in same space, development of the lightweight body and reduced size motor is inevitable. For traction system, KHST uses the concentrated power traction locomotive instead of the distributed traction system. That has more advantages in reducing total weight of traction system. And by using improved articulated bogie, total number and as a result, total weight for train bogie can be reduced. Articulated bogie has demerit of inconvenience in maintenance but KHST can make use of maintenance facilities of KTX. The brake system of high speed train has various problems such as adhesion limit, heat emission, brake pressure limit. KHST uses electrical (regenerative and rheostat) and frictional (disk and wheel) and even non-contact type eddy current brake. And by using brake blending unit, KHST can make combination according to speed and braking condition. Although KHST will be operate with 11 or 20 vehicles in a commercial operation, the composition of the first prototype train will consist of seven vehicles. In Fig. 2, we can see that it has 2 power cars -locomotives- at both ends (TP1, TP2), 2 motorized cars is next to them (TM1, TM5), and 3 trailers is located in the middle of the train. (TT2, TT3, TT4)

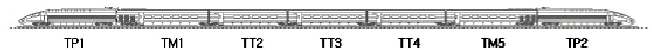

Fig. 2 Composition of the Prototype KHST

### 3. KOREAN HIGH SPEED TRAIN

The technology of the high speed train consists of almost every fields of the modern industry. Technology such as vehicle, mechanics, electronics, control, communications, materials, constructions etc are all mixed together and has the characteristics of complex technology congregation. This means that the success of single development project gives enormous growth of technology level of entire industry. The KHST development project was started in Dec. 1996. The final goal of the project is to develop the prototype high speed train running 350 km/h, which is 16.6% increased speed compared with TGV-Korea (KTX) running 300 km/h. Major characteristics of KHST are as follows.

- | 350 km/h maximum operational speed

#### 3.1 Constitution of the prototype KHST control system

KHST has chosen TCN system for the connection of various onboard equipments. In Fig. 3, you can see the controllers and network equipments of the prototype KHST. The prototype KHST consists of 7 vehicle. Controllers in a same vehicle compose a network segment of the vehicle bus called MVB (Multi-function Vehicle Bus). And each segment is connected to the train bus called WTB (Wire Train Bus) through the gateway (G/W) that is placed in each vehicle. Almost all major controllers are connected by TCN using MVB network card. As you can see in Fig. 3, the prototype train is controlled by the following controllers.

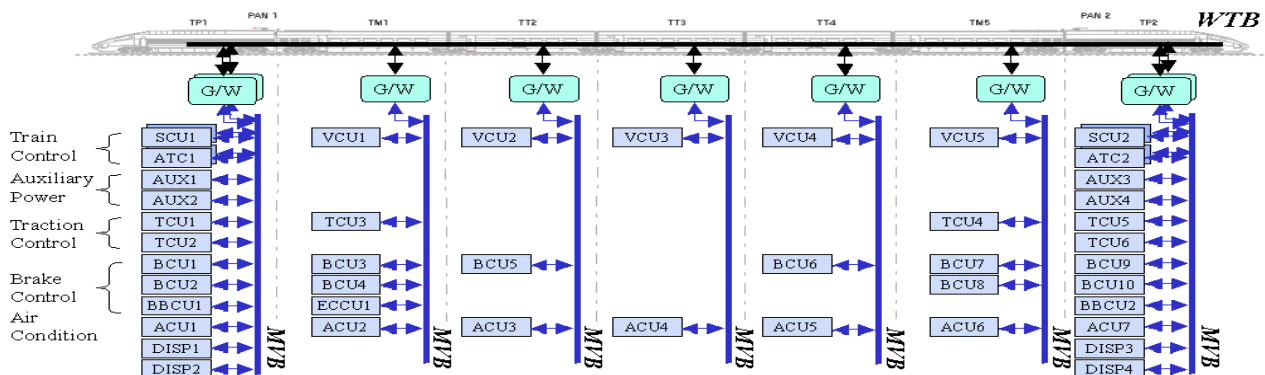

Fig. 3 Control equipments and network configuration of the prototype KHST

- | Supervisory Computing Unit (SCU)
- | Automatic Train Control Unit (ATC)
- | Auxiliary Power Controller (AUX)
- | Traction Control Unit (TCU)
- | Brake Control Unit (BCU)
- | Brake Blending Control Unit (BBCU)
- | Eddy Current Control Unit (ECCU)
- | Air Conditioning Control Unit (ACU)
- | VCU (Vehicle Control Unit)
- | DISP (Train Status Display)

SCU is the main computer that supervises the major train activities and most of other controllers are governed by SCU. Being a key controller of the train, SCU is implemented in a fault-tolerant method. Hot backup SCU is prepared for a safety and availability of the train in case of the primary unit's failure. ATC, which is critical to speed control, is also designed in a fault-tolerant system. ATC has the function of ATS (Automatic Train Stop), which is closely coupled with the ground equipments. The maximum permissible running speed on a block depends on ATC. Including these two major units, all other units compose one MVB segment. Each vehicle has one MVB segment and the KHST prototype train has seven definite MVB segments. Each MVB segment has single gateway unit, so that MVB can be linked to upper layer of network, WTb. However, for each locomotive where SCU resides, the network connection to WTb should not be disrupted at anytime. If there is a problem in the gateway of a locomotive, all units of other vehicles have no way to receive commands from SCU. In that case, the train will stop by emergency brake. For this reason, the gateway of locomotives also has a concept of redundancy. The secondary gateway will control the network in case of primary gateway's breakdown.

In Fig. 4, you can see the photograph of newly developed prototype KHST.



Fig. 4 A photograph of developed prototype KHST

#### 4. FAULT DIAGNOSIS METHOD

Before transmitting or receiving of signals using TCN, the devices should have a proper method of deciding whether TCN is in normal state or not. And even though TCN is in normal state, a device also has to have another proper method for verifying whether the received signal is valid or invalid. Considering that a large number of researchers are developing

numerous onboard controllers for a high speed train, a common method for diagnosis of TCN status and proper way of reaction to the faulty condition of network is greatly important matter to all developers. These works are greatly important for the behavior of entire train system. If the onboard controllers would react differently to the same fault, nobody can estimate how the system will move. The entire system maybe falls into chaotic state or even catastrophe.

For the fail safe feature, TCN has its own various characteristics such as the medium redundancy(dual line), bus administrator redundancy, freshness time check, check variable and so forth. But some of those fail safe characteristics in standards says only general parts, so developers of onboard controllers must be provided with some specific guideline of the fault diagnosis of the network, and how to react to those faults.

Until now there were no common rules for fault diagnosis, breakdown of the network, and recovery. The application programmers of onboard controller have to decide it by their own logical decision. And there also were no directives for how to use check variable or what is the timeout count for freshness check.

When there is some network trouble, the reactions of onboard equipments are a little bit different each other and sometimes this discordance causes problems to entire system. Therefore the necessity for common guidelines for detection of network problems and recovery has been escalated. In this paper, guidelines for TCN network problems are introduced with algorithms, block diagram, and flowchart.

#### 4.1 Basic causes of TCN faults

You can find various TCN fault are specified in CSS (Control System Specification) document. The CSS is a document for development of control system for KHST prototype train. It defines criterions for software programming, control and diagnosis system, interface signals and so forth. TCN fault are numerous by many reasons. However, from the point of view of application programmer, they can be divided into 2 groups as below.

- | Interlink problems with MVB board
- | Erroneous signal that was received by MVB board

In other words, onboard controller (application program) can classify TCN faults as one case of connection problem with MVB board that gives interlink with TCN, and another case the signal that was received by MVB board when TCN is in normal state. In both case, describable fault phenomenon for the application program's view point, and relevant work out for those faults are as following.

#### 4.1.1 Fault diagnosis using mutual heartbeat check

A device for connection with TCN of each onboard controller is called as MVB board. Each controller has to check the status of MVB board in order to verify the continuous link with TCN. Similarly, MVB board has to check the host controller (onboard controller) to report current status of the host controller to other devices over TCN. Mutual heartbeat is a tool for giving a notification of it's own validity to opposite side. By checking the heartbeat of opponent, the controller or communication board can decide its own mode of operation. Heartbeat information is located in the dual port memory region. It consists of two 16 bits word memory in service area of MVB board. Host controller accesses this heartbeat through various bus architectures (VMEbus, PC104

bus, modified ISA bus).

I 11B : the linked variables are undefined

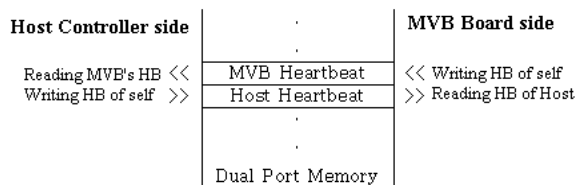

Fig. 5 Mutual heartbeat check

**4.1.2 Validity check of the network signal**

As mentioned above, a onboard controller is able to check the interlink problem with its own MVB board through the mechanism of mutual heart beat check or by probing dual port memory, or bus error check.

However, even though its own network board is in normal state, it exists sometimes that the controller receives the erroneous signal from TCN. Therefore in such case, controller should have the proper method to check the validity of a received signal. In the document of TCN standards, there are two useful mechanisms for verification of the signal that was received from network.

**4.2 Sink time supervision**

Sink time supervision is one of the basic method of verifying the validity of network signal. In TCN, every network signal data is contained in a data cluster that is called 'port'. Onboard controller can have the information of how much the time has been passed from the last update (receiving new data from the network) by accessing the sink time data of the corresponding port. Sink time data is provided by the variable that is linked to the special timer called freshness timer. This data is cleared every time when a new data is received from the bus, and increased every freshness time period has reached. Therefore by accessing sink time data, the application program is able to find out that how old the data was updated.

Current fresh timer has a resolution of 16 msec and maximum value of 4 sec. One thing you should be careful when using this sink time data is that this data does not mean the time when the source device has written a value (Source Time Supervision). For example, when the source and sink devices are not in the same MVB segment, the sink time data does not mean the time when source device transmits the data to the MVB, but it means the time when the gateway device has written the data to MVB after it has received from WTB. If the value of freshness data that is 3 times more than individual transmission period, the corresponding port is considered to be invalid. This is the basic decision criterion for sink time supervision error used in KHST prototype train project.

**4.3 Check variable**

Check variable is another basic method for verifying the validity of network signal. It is a dynamic variable that can be altered actively by the application program. It is a part of the port data that has the form of ANTIVALENT2 (2 bits). It has the following meaning.

- I 00B : the linked variables are erroneous or suspicious
- I 01B : the linked variables are assumed to be correct
- I 10B : the linked variables are forced value

Several process variables may share same check variable and some process variable do not has associated check variable. Check variable is important because it gives a verification concept of source time supervision. It gives a chance to the source device for containing the validity of network variable. You can see the example of dataset structure that has some check variables in it. A process variable can display its connection with its check variable through putting information of CHK\_OFFSET in PV\_NAME structure. CHK\_OFFSET shows the position of the check variable from the beginning of the dataset.

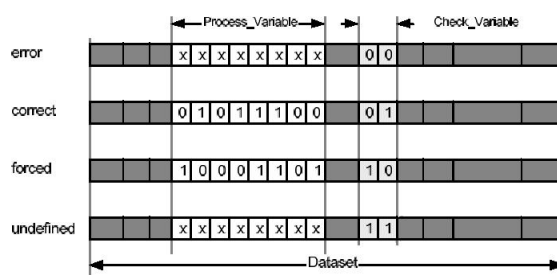

Fig. 6 Check variables

Check variable has a special meaning for the gateway application program. Gateway is a pathway between two separate networks. Therefore process variables and its check variables should be transferred bidirectionally from one network to the other. Task in the gateway who's in charge of this function is called the process data marshalling. When the device has some problems in sending data, some ports that the device are to send can not be delivered to network. In this case, gateway (The process data marshalling task) should notice those ports by sink time supervision and should clear (set to zero) those ports data. The clearing those ports data also makes associating check variable to 00. Therefore the receivers located in another network are able to recognize the status of those process variables by checking that the associating check variable is erroneous (00B).

**4.4 Validity check according check variable existence**

Network signal data does not have independent area for check variable. As you can see in Fig 6, the check variables are allocated inside the port data area. Considering that entire data area is limited by the memory (traffic memory), it is hard to protect all process variables with check variables. To save the data area of the traffic memory, it is general to share a single check variable for multiple process variables, or allocate check variable only to important process variables. As this memory and network bandwidth limitation is unavoidable to all TCN application, KHST also has the same problem.

Because not every process variables are protected by check variables, we need to set a criterion for fault diagnosis of process variables that has no check variable as well as the process variables with check variables.

**4.4.1 Process variables with check variable**

Fault diagnosis of the process variables that have check variable is executed by coincidental check of sink time supervision (freshness timer check) and check variable. If the results of both checks are probed to be valid, received process variable is considered to be valid.



If we refer to the network data table currently used in KHST prototype train, the majority of process variables that has check variable are the status variables. Every onboard controller has a status variable to report its status to other devices, and it has a process variable name of 'DeviceName\_STATUS'. Supervisory controllers that are located in both end of locomotives (SCU1, SCU2) checks the status of all onboard controllers using these process variables and save the check result to process variable named 'SCUx\_TCN\_STATUS' (x=1,2 accordingly).

This process variable is 64 bits, and TCN connection status of every onboard controller is stored in this variable. SCU1 and SCU2 distribute this variable to entire onboard controllers.

**4.4.2 Process variables without check variable**

Because the sink time supervision can not give a complete validity assurance, the process variables without check variable should use another mechanism to verify the validity of the network signal.

This is done indirectly by using the variables received from SCU. The above process variable SCUx\_TCN\_STATUS has the information regarding the TCN connection status of every onboard controller checked by SCU.

When a onboard controller received a process variable from another controller, it checks whether the variable has the associating check variable. If the process variable has no check variable, the onboard controller should check the TCN status of source device by probing a bit of SCUx\_TCN\_STATUS.

If the TCN state of source device is abnormal, the process variable is considered as invalid data. If the status is ok, then the validity of the received process variable is verified by checking freshness timer. This mechanism of fault diagnosis for TCN process variable is depicted by flowchart as in Fig. 7.

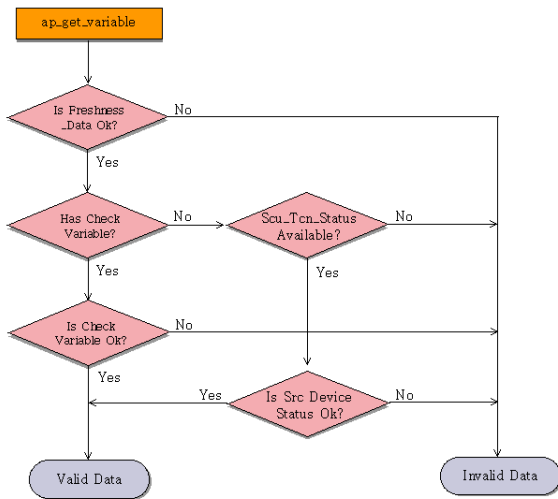

Fig. 7 Flowchart for the validity check of a received network signal

**5. CONCLUSION**

In this paper, you can see the diagnostic methods of the TCN that is a base network of the prototype Korean high speed train. As it was mentioned above, in the case of the

modern digital and distributed control system, the stability and performance characteristics of the entire system is greatly dependant upon the main network system.

In order for fail safe operation of entire system, developers of various onboard control equipments need the common diagnostic methods and the proper solutions for the abnormal status of the network. Using freshness data and check variable of TCN architecture, this paper have shown how to check the status of the network, and also propose the validity check of signal data that has no check variable.

**ACKNOWLEDGMENTS**

This research paper is based on the results of G7 project that was sponsored by the MOCT (Ministry of Construct and Transportation) in cooperation with the MOST (Ministry of Science and Technology) and the MOCIE (Ministry of Commerce, Industry, & Energy).

**REFERENCES**

- [1] IEC 61375-1 "Electric Railway Equipment – Train Bus Part 1 : Train Communication Network", 1999
- [2] Hubert Kirmann et al, "The IEC Train Communication Network", *16th Conference on Transportation Systems, KoREMA, Split/Ancona, November, 1996*
- [3] Y.J.Kim, "The Present State of Technology Development in High Speed Trains", *KIEE Summer Conference, 1998.*
- [4] Y.J. Kim, J.S. Kim, H.J. Ryu, C.H. Cho, J.H. Lee, D.Y. Park, "Trends in Technology of International High Speed Train", *KIEE Summer Conference, 2000.*
- [5] C.H.Cho, J.D.Lee, J.H.Lee, K.H.Kim, Y.J.Kim, "Design of TCN based Train Control System for the Korean High Speed Train", *ISIM2000, 7-11, Oct. 2000*
- [6] C.H.Cho, J.D.Lee, J.H.Lee, K.H.Kim, Y.J.Kim, "Design of Train Network Simulator based on Train Communication Network", *ISIE2001, 12-16, Jun. 2000*