

Dynamic Investigation of the Brushless DC Motor

Surachet Sirilappanich*, Nitipong Somchaiwong**, Sawai Pongswatd* and Prapart Ukakimapurn*

*Department of Instrumentation Engineering, Faculty of Engineering, King Mongkut’s Institute of Technology Ladkrabang
Ladkrabang, Bangkok, 10520 Thailand
(Tel : 66-2-739-2406; Fax : 66-2-739-2407 ; E-mail: klsawai@kmitl.ac.th)

**Department of Electrical, Faculty of Electrical, Rajamangala Institute of Technology, Chiangrai Campus
Chiangrai, 57120 Thailand
(Tel : 66-5-372-9600-8; E-mail: thaijobless@hotmail.com)

Abstract: The analysis and simulation are the method to study the behavior, response, and specification of the driver device. This paper proposes brushless DC drive which using the vector control technique. The encoder is used detect the rotor position and decode to Three-phase step signal. The step signal is modulated with triangle signal and change to the pulse width modulation (PWM) signal. The PWM signal is used for control the input power of the motor based on the vector control technique. The experimental results of the driver circuit and motor response performed under the following condition: as the motor was started, change the load torque, and vary the supply voltage. The experimental performs with a dynamometer and the test results are compared to the simulation method is the same result.

Keywords: BLDCM, 6-step signal, PWM, Encoder, Vector Control, Dynamometer

1. INTRODUCTION

Brushless DC Motor (BLDCM) has a compact structure low mechanical loss because it no brush. The mechanical and speed response of BLDCM is better than the original motor, when it is compared with an initial machine as size as it. However, BLDCM can not operate while it without a particular driving. So that before design the driver system of the BLDCM must be known the parameter and specification of the motor. This paper applies the motor parameter from the simulation results [1] for designing the driver. Mitsubishi motor Model HA_SC43 has been chosen for case study. The Mitsubishi motor is a three-phase synchronous motor and rotor is permanent magnet. This paper presents the technique to design the BLDCM driver based on the vector control. The driver uses the encoder for detecting the rotor position and decoding the three-phase six-step signal. The Three-phase step signal is fed to the pulse width modulation circuit for controlling the power module before fed to the motor. The experiment performs on the dynamometer and compares the experimental result with the simulation result.

2. THEORY

BLDCM is a similar structure with the alternating current generator, which is a type of permanent magnet synchronous motor. The armature coil are wound at stator and the rotor is a permanent magnet. The stator coil lashing will be wrapped like the alternating current generator in the several phase but BLDCM must be detected the pole of rotor. (magnetic pole) for control the sequence of electronic switch.

Basic of BLDCM

The basic of three-phase BLDCM can be shown in the Fig.1. Three-phase bridge inverter controls the input power of motor and phototransistor is used detecting the rotor position.

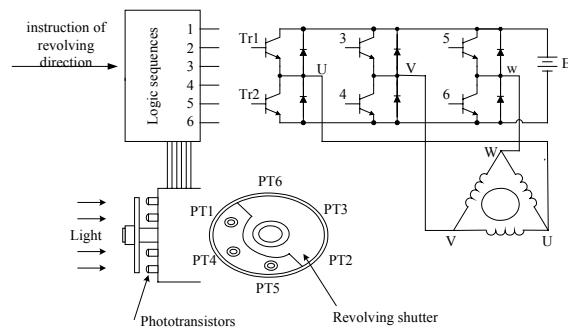

Fig.1 Basic structure of Three-phase BLDCM.

The output signal of phototransistor number PT₁,PT₄,PT₅ is fed to the transistor Tr₁,Tr₄,Tr₅ respectively. While the Tr₁,Tr₄,Tr₅ are close circuit the current is fed from U and W to V point. Therefore the magnetic field occurs at the UV and WV branch and can be shown in the Fig.2.

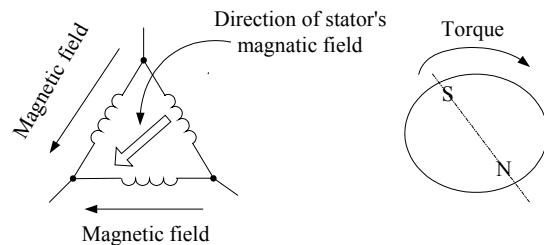

Fig.2 direction of magnetic field has been occurred

The magnetic field has been occurred at UV and WV branch of stator coil. The direction of stator’s magnetic field is 90° with compare the direction of the rotor’s magnetic field. The direction of torque at the rotor is the clockwise (CW) direction. So that the rotor rotate to the CW direction equal to 30° and the phototransistors PT₆ will be operate instead PT₅.

3. PRINCIPLE OF BLDCM DRIVER DESIGN

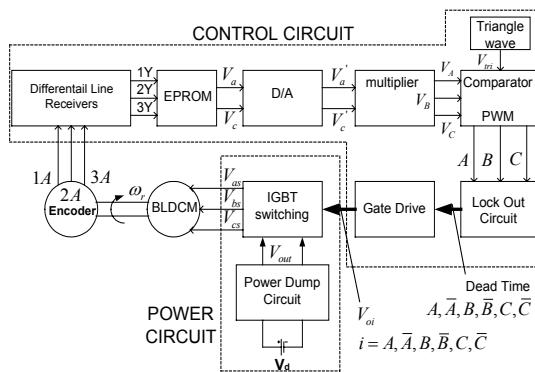

Fig. 3 Block diagram of BLDCM drive set in the controlled vector type

The Fig. 3 show the block diagram of BLDCM driver which consist of 2 main circuit

1. Control Circuit
2. Power Circuit

3.1 The control circuit

The control circuit generates the Three-phase signal for control the ON-OFF sequence of the electronic switch. The output signals of encoder are used to decode the Three-phase signal proper the rotor position. The Three-phase step signal is shown in the Fig. 4.

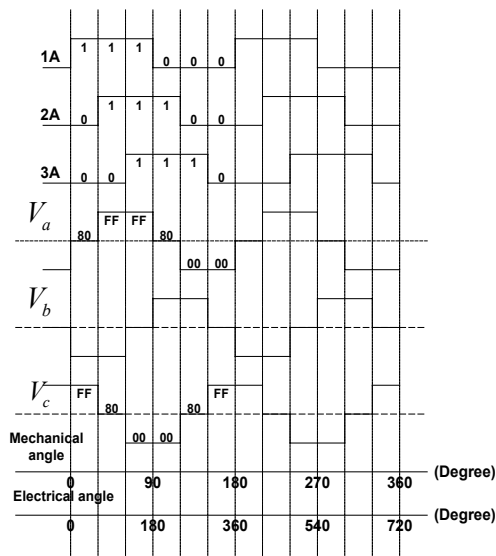

Fig. 4 Three-phase step signal

The 1A, 2A, and 3A signal are the output of the encoder. The signals are fed to differential line receiver circuit for adapt level of the 1Y, 2Y and 3Y signal respectively. The 1Y, 2Y and 3Y decode the V_a and V_c step signal and convert to $V_{a'}$ and $V_{c'}$ analog signal. The decoder circuit and D/A convert circuit can be shown in the Fig. 5.

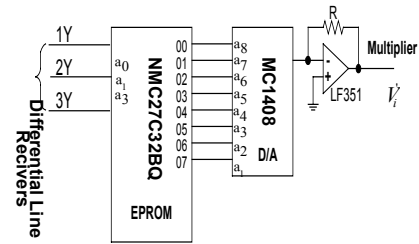

Fig. 5 Decoder Circuit and D/A Convert circuit

The decoder circuit uses EPROM NMC27C32 to decode the signal and uses MC1408 to convert digital signal to analog signal.

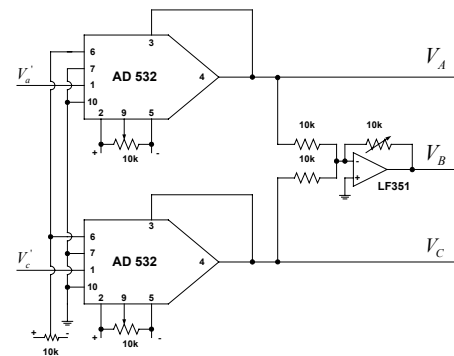

Fig. 6 Multiplier Circuit

The $V_{a'}$ and $V_{c'}$ are multiplied by AD 532 to V_A and V_C signal. The V_A and V_C signal is used generated the V_B signal, which is shown in the Fig. 7. Therefore the total signal will be three step signals.

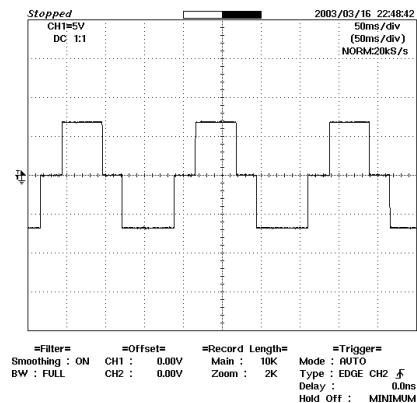

Fig. 7 The V_B step signal

The step signal is modulated with the triangle signal for generate the Pulse Width Modulation (PWM) signal. The triangle signal and the PWM signal is shown in the Fig. 8 and Fig.9 respectively.

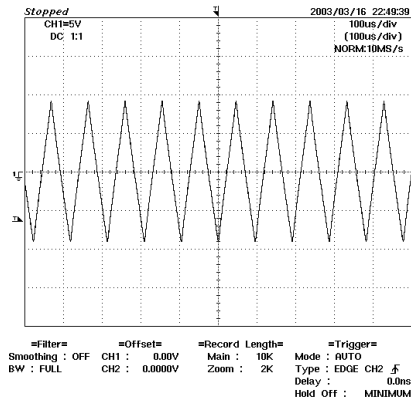

Fig. 8 The Triangle signal

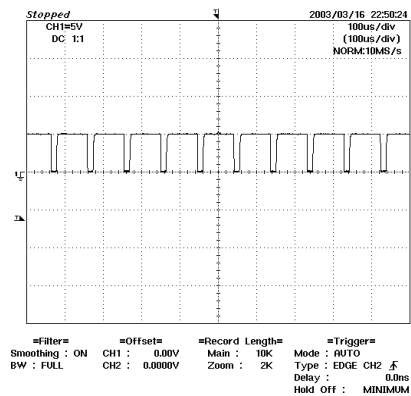

Fig. 9 The PWM signal

Before the PWM signal is fed to the driver circuit, it will be lock out the signal for preventing the short-circuit condition. The output signal of the lock out circuit can be shown in the Fig. 10.

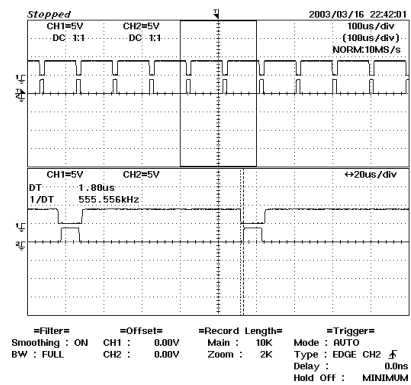

Fig. 10 The output signal of the lock out circuit

3.2 The Driver Circuit

The driver circuit control the input power of the motor depends on the PWM signal. The PWM signal has a 3 signal for Three-phase drive. The Three-phase driver is a power bridge module part No. IRG4PC50UD. The driver circuit is shown in the Fig. 11.

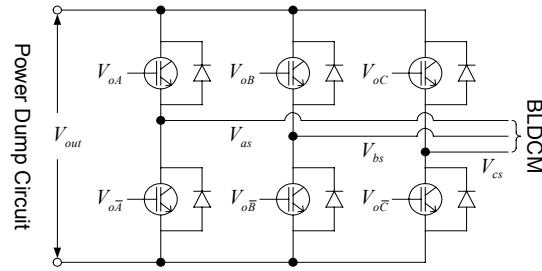

Fig. 11 The driver circuit

The driver circuit consists of 6 modules of IGBT and connects in parallel, which is driven by PWM signal.

4. THE EXPERIMENTAL RESULT

The experiment is performed on the Mitsubishi motor Model HA_SC43. The dynamometer is used record the mechanic response and the digital storage oscilloscope is used record the electrical signal.

The starting current and the speed response can be shown in the Fig. 12.

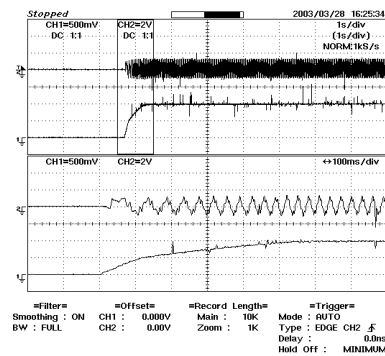

Fig. 12 The current signal and the speed response at the start condition.

From Fig. 12 show phase current and speed response of the BLDCM at the start condition. The motor current is a sinusoidal signal and the frequency is proportional to the motor speed. The motor current will be increase when the load is applied to the motor. Fig. 13 shows the motor current while the load is applied to the motor.

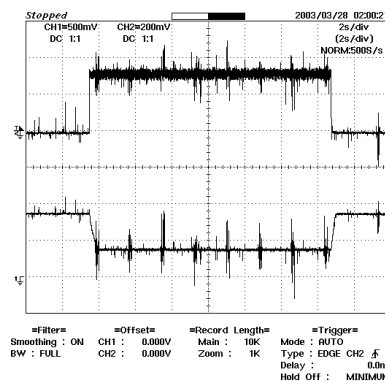

Fig. 13 The motor current and the speed of motor when the load is applied.

The speed response performs to vary the input voltage. The response in the Fig. 14 shows that speed of the motor depends on the input voltage.

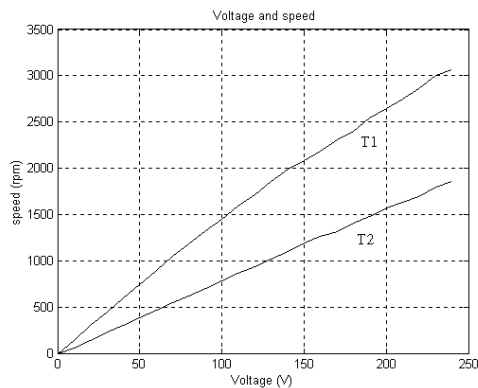

Fig.14 The speed response of the motor

The speeds respond of the motor is linearity with the supply voltage. The T1 and T2 show the speed response, which different the loads apply. The load torque of T2 is more than the load torque of T1.

5. SUMMARY

This paper presents the technique to apply the simulation result of the BLDCM for designing the driver circuit. The simulation result can be known the parameter of the motor, specification of the electrical device and the response of the system. This paper design the control circuit and the driver circuit with the simulation result. The experimental results of the driver system are similarly with the simulation result.

REFERENCE

- [1] I.Akons and A.Alexandrovitz, "Dynamic Invertigation and Simulation of Brushless Dc Motor" , Nineteenth Convention of , 5-6 Nov 1996 ,Page(s): 76 –82
- [2] J.M.D. Murphy and F.G. Turnbull, "Power Electric Control of AC Motor", Pergamon Rpress , 1988.
- [3] T.S.E. Miller, "Brushless Permanent – Magnet and Reluctance Motor Drives",Claverdon–Press–Oxford, 1989
- [4] T.J. Sokira and W.Jaffe, "Brushless DC Motor Electronic Commutation and Control" , Tab Book INC, 1989.
- [5] Y. Dote and S.Kinoshita, "Brushless Servomotors Fundamentals and Applications" Clarverdon – Press – Oxford , 1990.
- [6] P.C. Krause , "Analysis of Electric Machinery", McGraw – Hill Book company , 1987.
- [7] R.Krishnan, "Electric Motor Drives Modeling, Analysis, and Control " , Virginia Tech, Blacksburg. VA, 2001.