

A Study on the Development of Two side carrier Type Progressive Die for Multi-Stage Drawing Process

Sung-Bo Sim*, Chan-Ho Jang**, Sung-Taeg Lee**

* Pukyong National Univ. School of Mech.

** Pukyong National Univ. Graduate School

ABSTRACT

The production part requiring multiple processes such as piecing, blanking and notching are performed with a high production rates in progressive die. In order to prevent the defects of process result, the optimum of strip process layout design, die design, die making, and tryout with inspection etc. are needed. According to these factors of die development process, they required theory and practice of metal working process and its background, die structure, machining conditions for die making, die materials, heat treatment of die components, know-how and so on.

In this study, we designed and analyzed die components also simulated the strip process layout of multiple stage drawing by DEFORM.

Especially the result of tryout and its analysis become to the feature of this study.

KEY WORDS : Progressive die, Circular Lancing, Drawing, Pilot, Strip Process Layout

1. INTRODUCTION

The progressive die with multi-stage performs a series of sheet metal working at two or more stages during each press stroke to produce a piece part as the material strip moves through the die tunnel with a front and back gage. Press working through the optimum die design and its making has been become the purpose of industry by strip process layout with multi-stages.^{1,2)}

We used the part of precision production part(Fig.1)

in industrial production line.

So, this study needs a whole of press tool data, our field experiences, theoretical instructions, and ultra precision machine tool and its skillful operating and applications.

The added process of this work was FEM analysis by DEFORM. The result of this FEM analysis was very exactly that the output come to result in Fig. 2, Fig. 3 with nothing crack occurred on the drawing corners.

According to upper knowledge, this study could approach to the optimum die design. Furthermore the aim of least defects could be obtained mostly by revision on the tryout^{1,2)}

Table. 1 The parameter for FEM simulation of SPCC

	Unit	Value
Young modulus	GPa	200
Poison ratio		0.3
Tensile Strength	MPa	760
Yield Strength	MPa	380

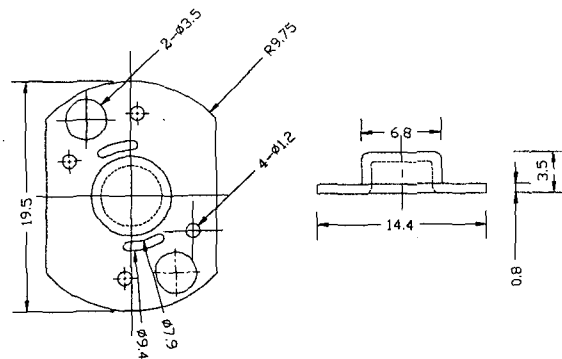

Material : SPCC Thickness : 0.8mm

(a) Production part drawing

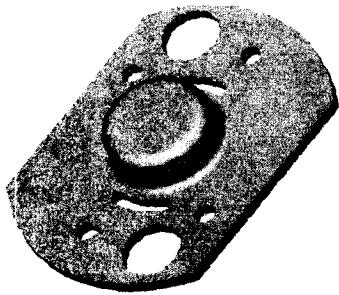

(b) Modelling of production part by IDEAS
 Fig. 1 Production part



(a) Mesh deformation of 1st-drawing

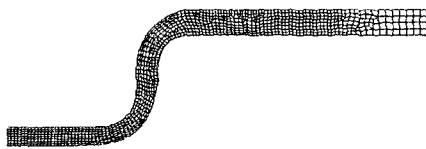

(b) Mesh deformation of 2nd-drawing

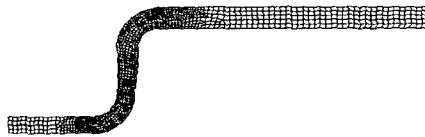

(c) Mesh deformation of 3rd-drawing



(d) Mesh deformation of 4th-drawing

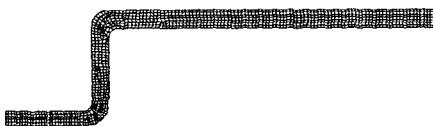

(e) Mesh deformation of 5th-drawing

Fig. 2 Drawings of mesh deformation on the each process by DEFORM

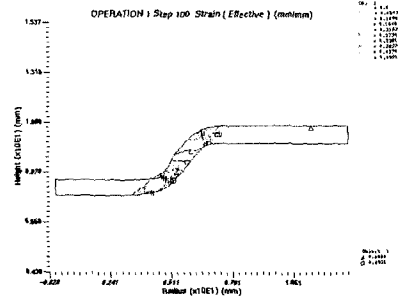

(a) Strain deformation of 1st-drawing

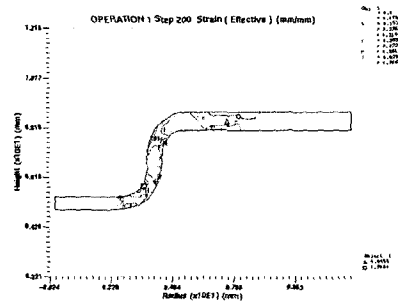

(b) Strain deformation of 2nd-drawing

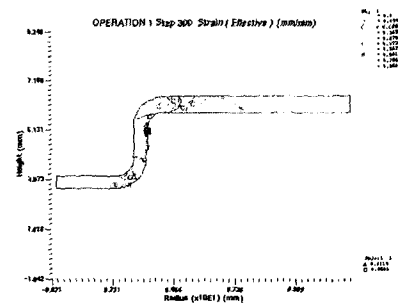

(c) Strain deformation of 3rd-drawing

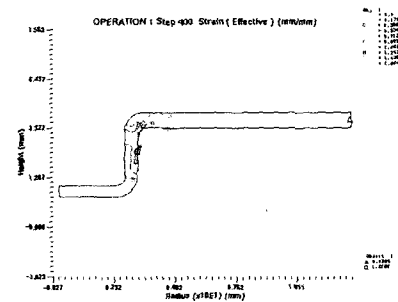

(d) Strain deformation of 4th-drawing

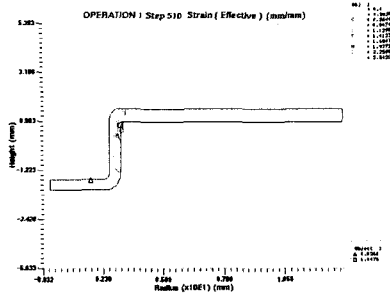

(e) Strain deformation of 5th-drawing

Fig. 3 FEM simulation result on the each process drawing by DEFORM

2. DIE DESIGN

2.1 Die Developing System

Table .1 shows the parameter for FEM simulation of SPCC.

Fig. 4 shows the die development system. In this system, it can be known that the production engineering, die making technology, standardization, trouble shooting, man power, purchase, tool, material, etc. are connected with software and hardware, corresponded instructions of wide and deep technology and it's theoretical background.¹⁻³⁾

Fig.5 Shows the one of die components drawing by

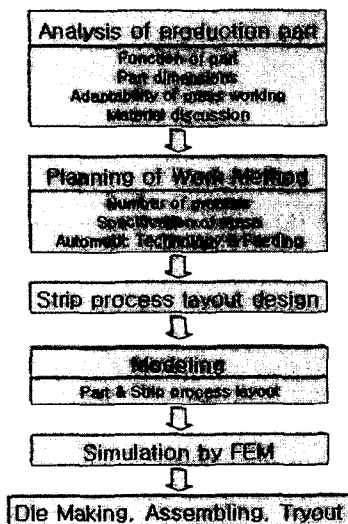

Fig. 4 Flow chart of die development system

visual Auto-Lisp under the Auto CAD and Window Environment. The other die components were designed with this method and experiences.

2.2 FEM Simulation

The drawing process was performed with FEM analysis by DEFORM. The result five steps drawing simulation by DEFORM is shown in Fig. 2, Fig. 3.

At this time, the base data of each step is described in Table. 2. The thickness of material on the five steps was reduced to 0.55mm(at the fifth drawing) more and more every step progressing thru. So the arrangement of tryout was performed very carefully through the fine machining of punch and die shoulders with a good lubrication.

The last consideration of this simulation was successful drawing process without the critical factors such as a crack phenomena of actual production part.

Table. 2 Basic data of 5 steps of drawing

	Punch Diameter	Punch Radius	Die Radius
1st drawing	10.5 mm	1.4 mm	1.0 mm
2nd drawing	7.3 mm	1.0 mm	0.8 mm
3rd drawing	6.4 mm	0.7 mm	0.6 mm
4th drawing	5.5 mm	0.4 mm	0.4 mm
5th drawing	5.2 mm	0.2 mm	0.2 mm

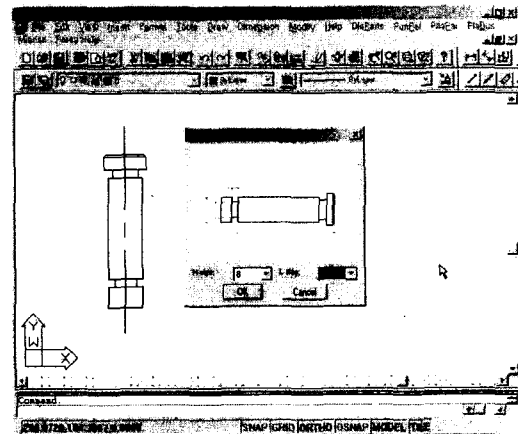
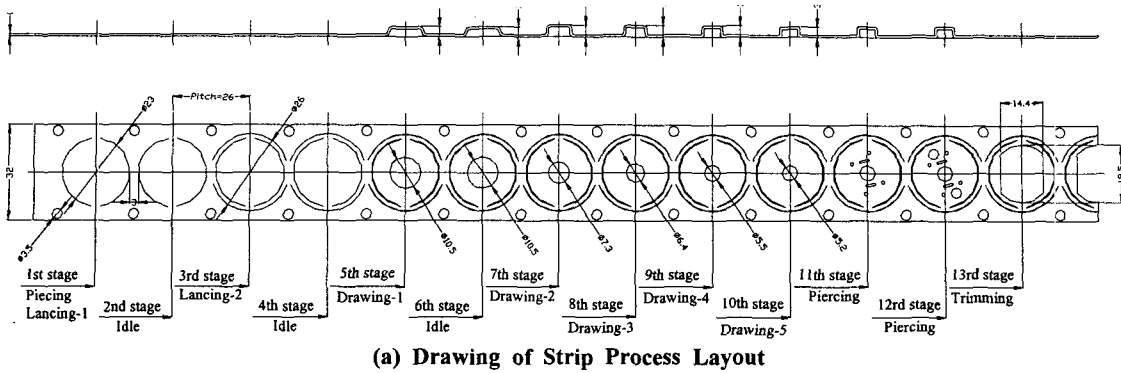

Fig. 5 Die component drawing by visual Auto-Lisp



(b) 1~13 stage of strip process layout modeling by IDEAS

Fig. 6 Drawing of Strip Process Layout

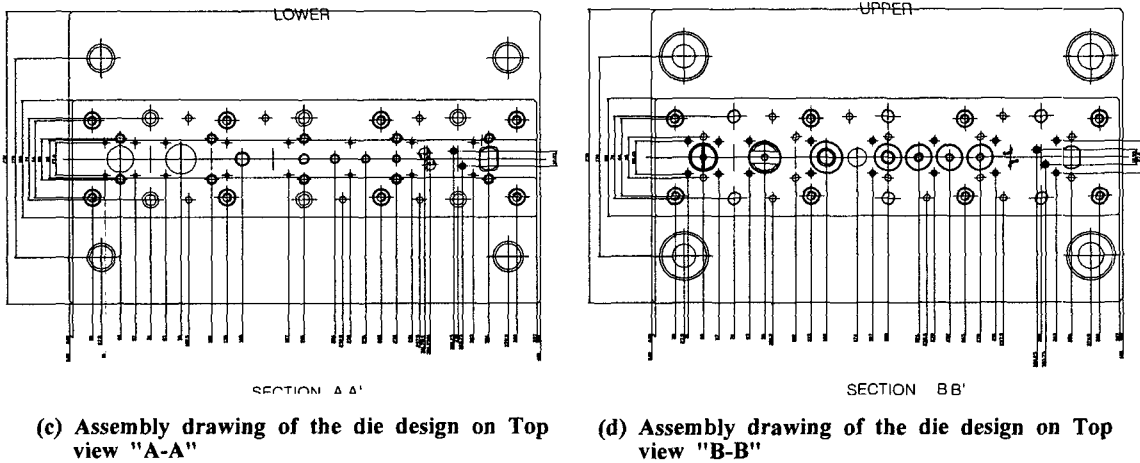
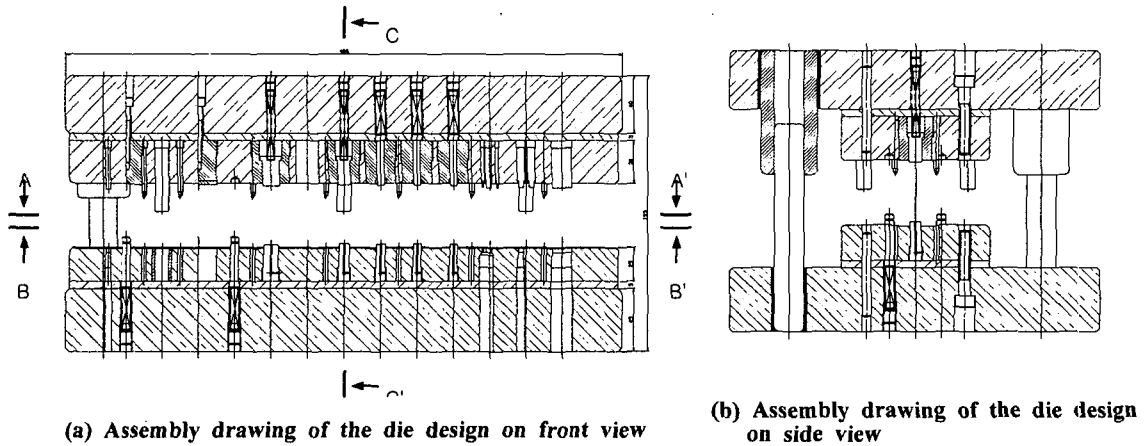

Fig. 7 Die assembling drawing

2.3 Strip Process Layout

The disposition of part on strip feed unfolding is the display with constant area repeatedly. Due to upper cause, it must be enough to the decision of part feeding distance (advance, pitch) and disposition of part on the strip layout must be performed exactly.

Tool designer's intention must consider that the best utilization ratio can be found the top of part arrangement. This is the optimum method of initial die design.^{1, 5-6)}

At this time we must refer the web size on the strip from database and experience too.

Fig. 6 shows the strip process layout design system. For the design of strip process layout, the first step is how to decide the feeding method which is according to the quantity of production part, material properties, and material thickness, the second step is same with a such as flow chart of Fig. 4. From the strip process layout designing method, the following strip process layout(see Fig.6) was designed. For the strip process layout it was considered that the proper sizes are strip width, web size, advance, side cutting allowance etc..

The first stage performs piercing and lancing, the second stage works idle, third stage performs lancing, fourth stage works idle, fifth stage performs first drawing, sixth stage works idle, seventh stage performs second drawing, eighth stage performs third drawing, the ninth stage performs fourth drawing, the tenth stage performs fifth drawing, the eleventh stage performs piercing, the twelfth stage performs piercing, the thirteenth stage performs trimming for complete production part.

In here, the pilot works to take a stability of strip feed and its location as a two side carrier, also the idle stage has function of die allowable space and trouble shooting used for die arrangement.

Fig 6. shows the die assembling drawing.

In this die design result, the most important die mechanism factor is inserted component system of die construction due to long life of die using with tungsten carbide materials and high alloy steels.

3. DIE MAKING AND TRYOUT

3.1 Die Making

Punch and die block is main part in die making. In this study, we decided the size of punch and die block depending on data base, theoretical background and our own field experiences. The machining of punch and die block belong to the precision machine tool working, continually raw material cutting, milling, turning, drilling, shaping, profiling, and then heat treating, electronic discharge machining (EDM, Wire-Cut), jig grinding, especially, CNC machining

In this study, we used ordinary machine tools, CNC machine tools and EDM etc..^{6, 7)}

On the accuracy of the each fitting components, namely, with combination of the following tolerance, the first is guide bush and guide post(outer or inner) tolerance H7(hole) h6(shaft) and the die set and guide post tolerance are H7(hole) p5(shaft) for a tight fitting. Punch plate and punch tolerance are H7(hole) m6(shaft) for a tight fitting with minor interference. The second is stripper and the punch tolerance is H7(hole) h6(shaft) too. Die inserting hole and die insert button are H7(hole) m6(shaft) for a minor tight fitting, too. These fitting tolerances are very careful factors for die making because whole die setting method must be within fine central punch and die activities for the symmetrical equalized clearance to the left and right side each other.

3.2 Tryout

Fig.8 shows the actual strip process result and its produced part from tryout working(100 tons power press, 100mm stroke, 40 spm). In this real process strip, we could confirmed the real process for making the production part. Also we checked every dimension of production part with tolerance control. We could find the jamming problem such as the material strip through the guide tunnel on the die block surface. Also, when the material strip pass through the tunnel, the auto-feeding attachment

operation must be checked very exactly. The trouble shooting of this problem comes from die setting skill and technology. Furthermore, the production part from try out was very fine by inspection, too.⁸⁾

At this time, the check of die failures was performed through the production part and strip of every stage with punch and die edge by the survey and fine instruments. We considered that all of the failures cause are associated with stresses present in the die, which are generated during either its manufacturing, its using life or others.⁹⁾

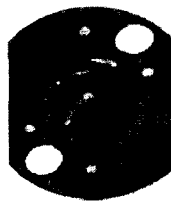

(a) Actual production part



(b) Actual strip by tryout

Fig. 8 Actual part and strip by tryout

4. CONCLUSION

This study performed optimization method by visual Auto-Lisp under the Auto-CAD and WINDOW environment and FEM simulation on the five steps theoretical calculating and our skilled experiences with the others of database including wide the other of instructions

The result are as follows;

- (1) The result of FEM simulation was very exactly for good production of production part for this progressive die development of Five step drawing
- (2) The results of fine quality of production part were accomplished by tryout after die components making and its assembling.
- (3) The auto-feeding method of its attachment was

comparatively effect for this production part material strip progress.

- (4) The visual Auto-Lisp under the Auto CAD and WINDOW environment was useful for the design of die components.

ACKNOWLEDGEMENT

This work was supported by the Brain Korea 21 project in 2001.

REFERENCES

- (1) Sim, Sung-Bo, Park, Sun-Kyu, May(1999), Development of the Practical and Adaptive Die for Sheet Metals(1), Proceedings of KCORE Conference, pp. 141~148.
- (2) Sim, Sung-Bo, Song, Young-Seok, May,(1999) Development of the Practical and Adaptive Die for Sheet Metals(2), Proceeding of KCORE Conference, pp. 149~155.
- (3) Karl, a.Keys,(1982) Innovation in Die Design, SME, pp. 71~99.
- (4) Hutota, M., (1975) Preworking and Die Making, Higan Tech. Paper Co., pp. 121~180.
- (5) Hutota. T,(1969) Databook of Pressworking Process Design, Press Tech, Vol. 7 No. 13, Higan Tech. Paper Co., pp. 1~201.
- (6) Donald, F. Eary, Edward, A. Reed, (1982), Techniques of Pressworking sheet Metal, Prentice Hall, Inc, Tool and Die Failures, ASM, pp. 18~31.
- (7) Sung-Bo Sim, Young-Seok Song,(1999), Development for Practical and Adaptive Progressive Die for Design and Making of Marine Part Sheet Metals(1), Inter. Jour. of Ocean Eng. and Tech., KCORE, Vol. 2 No. 2, pp. 19~25.
- (8) M. I. Moto,(1969), Press-Progressive Die Higan Industrial Paper Co.
- (9) M. H. Moto,(1970), Press working and Die Making, Higa, Industrial Paper Co.