

# Development of a distributed rainfall–runoff model with TIN–based topographic representation and its application to an analysis of spatial variability of soil properties on runoff response

Yasuto TACHIKAWA

*Associate Prof., Disaster Prevention Research Institute, Kyoto University, Uji 611-0011, Japan*

Michiharu SHIIBA

*Professor, Department of Civil Engineering Systems, Kyoto University, Kyoto 606-8501, Japan*

**ABSTRACT:** A TIN, Triangulated Irregular Network, based topographic modeling method and a distributed rainfall-runoff model using the topographic representation is presented. In the TIN based topographic representation, a watershed basin is modeled as a set of contiguous non-overlapping triangular faces: the watershed basin is subdivided according to streamlines to deal with water movement one-dimensionally; and each partitioned catchment is approximated to a slope element having a quasi-three-dimensional shape by using cubic spline functions. On an approximated slope element, water movement is represented by combined surface-subsurface kinematic wave equations considering a change of slope gradient and slope width. By using the distributed rainfall–runoff model, the effects of spatial variability of soil properties on runoff response are examined.

## 1 INTRODUCTION

The effect of topography on runoff characteristics is a major impact on hydrologic response, therefore to develop a topographic representation method for natural landscapes and construct a distributed rainfall-runoff model using the topographic representation are fundamental to improve the accuracy of flood runoff prediction. There are three principal methods for representation of topography using a network of elevation data, which are grid-based networks, contour-based networks, and Triangulated Irregular Networks, or TINs (Moore *et al.*, 1991). Grid-based networks are the most common form of Digital Elevation Models (DEMs) used by many researchers for topographic modeling and analysis of a river basin. When the networks are used for dynamic hydrologic modeling, some devices may be needed because they cannot represent various shapes of mountainous slopes such as topographic convergence, divergence, convex or concave. On the other hand, contour-based networks can deal with them appropriately. Moore and Grayson (1991) developed TAPES-C which automatically partitions a catchment by streamlines, and proposed a contour-based form of a distributed hydrologic model. However it might be suitable only for a small scale catchment because of heavy data storage and much computational burden.

To overcome these faults, we proposed a method to model landscapes by using TIN-DEMs (Tachikawa *et al.*, 1994), and developed a distributed rainfall-runoff model based on TIN-DEMs (Tachikawa *et al.*, 1996). The system generates contiguous non-overlapping triangular facets each of which has only one side through which water flows out. The structure of the TIN-DEMs made by the system allows us to partition a catchment into slope elements according to streamlines and to treat water movement one-dimensionally. Using the topographic modeling method, water movement is represented by combined surface-subsurface kinematic wave equations considering a change of slope gradient and slope width, and discharges from distributed slope elements are routed to a basin outlet through a channel network.

The proposed model is a physically based spatially distributed model which has advantages for the study of basin change impacts. When we apply the model for solving an actual problem, how to evaluate many spatially distributed model parameters becomes an important subject. One of the methods to cope with the subject is to investigate the influence of spatial distributions of model parameters on rainfall-runoff simulation results. A knowledge about what information of model parameters has dominant effects on runoff simulation will be useful to determine model parameters. For this purpose, the model is applied to the Shirasaka experimental basin (0.88km<sup>2</sup>) in the Tokyo University Forest in Japan, and the effects

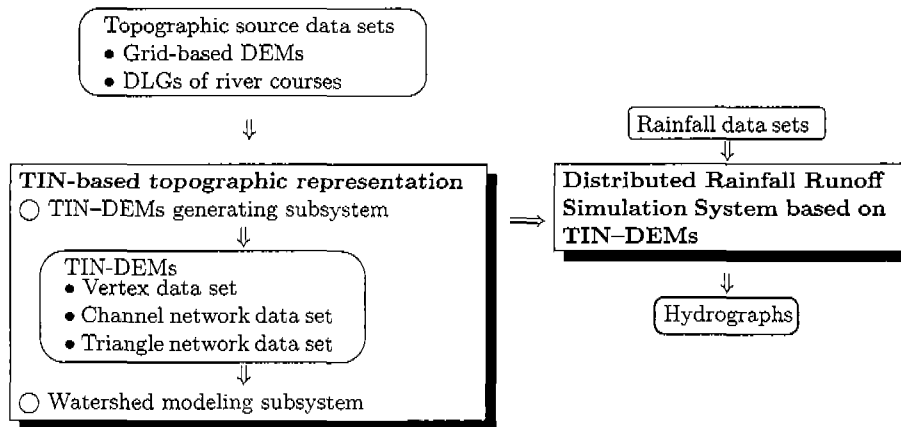

Figure 1: Flow diagram showing the logical movement of data sets from topographic source data to the runoff simulation system.

of spatial variability of soil properties on runoff characteristics are examined (Tachikawa *et al.*, 1999).

This paper is organized as follows: in section 2 and 3, our distributed rainfall-runoff model is described, and in section 4, the effects of spatial variability of soil properties on runoff characteristics are examined by using the distributed rainfall-runoff model.

## 2 TIN-BASED TOPOGRAPHIC REPRESENTATION METHOD

### 2.1 TIN-DEMs data structure

Figure 1 shows the logical movement of data sets for the total system. Source data sets to make a TIN-DEM representation are a grid-DEM and a Digital Line Graph(DLG) of river courses. By processing the source data sets as described by Tachikawa *et al.* (1994, 1996), three data sets, a triangle network data set, a vertex data set, and a channel network data set are produced for representing basin topography by using TIN-DEM data structure. A sample triangle network and its data sets having TIN-DEM data structure are illustrated in Figures 2 and 3.

A vertex data set contains  $x$ ,  $y$  and  $z$  values of vertices which are indexed by a number given to specify them. A triangle network data set contains properties of triangles. Each triangle is described by indices of its three vertices, indices of three triangles which are adjacent to the triangle, three side-attribute-indices which specify whether water flows into a side, along a side, or out of a side, three side-component-indices which specify whether a side forms a part of valley, channel, slope, ridge, or boundary of a study area, and unit normal vectors of the triangular facet. A value of a side-attribute-index is determined by the cross product of the steepest descent vector of a triangle and the vector of a side of the triangle. A value of a side-component-index is determined by side-attribute-indices of sides which are held in common by adjacent triangles. If common sides of adjacent triangles are composed of an out-flow-side and an out-flow-side, the sides represent a part of valley. Similarly, if composed of an in-flow-side and an in-flow-side, the sides represent a part of ridge. All indices are stored in order of a counterclockwise direction.

For a logical representation of a channel network in a computer, a channel network is represented by a set of links, which are sections of a channel network between an end point of a channel network and a confluence or a confluence and another confluence. Each link is indexed by a number given to specify it. A channel network data set is represented by an index of a link, an index of the downstream link, indices of the upstream links, indices of vertices which form the link, and indices of triangles which are in contact with the link.

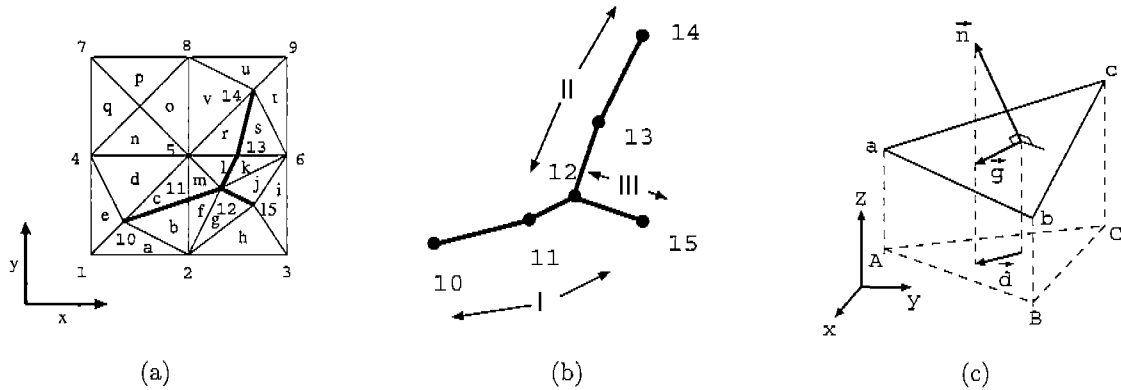

Figure 2: Schematic representation of a basin topography by using TIN-DEMs; (a) a sample triangle network; (b) a sample channel network; (c) a sample triangular facet.

(a)

vertex	x	y	z
1	25.00	100.00	301.25
2	50.00	100.00	287.55
3	75.00	100.00	288.89
4	25.00	125.00	311.22
⋮	⋮	⋮	⋮

(b)

no. of link	no. of downstream	no. of upstream	no. of vertices	right triangle	left triangle
I	null	II, III	10, 11	c	b
II	I	null	11, 12	m	f
III	I	null	13, 14	r	s
			12, 15	j	g

(c)

triangle	no. of vertices	adjacent triangles	side-attribute* -indices	side-component† -indices	unit normal vectors
a	1, 2, 10	NULL, b, c	3, 3, 1	0, 2, 2	-0.71, 0.71, 0.07
b	2, 11, 10	f, c, a	3, 1, 3	2, 3, 2	-0.71, 0.71, 0.07
c	11, 3, 10	m, d, b	3, 3, 1	2, 2, 3	-0.89, -0.41, 0.09
⋮	⋮	⋮	⋮	⋮	⋮

\*side-attribute-index : 1:out-flow-side, 2:along-flow-side, 3:in-flow-side.  
†side-component-index : 0:boundary of TIN-DEM, 1:valley segment, 2:slope segment, 3:channel segment, 4:ridge segment.

Figure 3: Sample data sets of the TIN-DEMs shown in Figure 2; (a) vertex data set; (b) channel network data set; (c) triangle network data set.

## 2.2 Procedure for generating TIN-DEMs

The system to generate TIN-DEMs consists of following five procedures.

### 2.2.1 Preprocessing

A polygonal channel network (Figure 2(b)) is produced. It is made up of polygonal lines which are composed of the intersections of mesh on a grid DEM and a DLG of river courses.

### 2.2.2 Triangle generation

A triangle network data set is generated from a grid DEM and a polygonal channel network data set. For a grid which has no channel segment in it, a new vertex is added in the center of the grid, and it is subdivided into four triangles. Elevation of the added vertex is interpolated from the elevation of four neighboring vertices. For a grid which has one channel segment in it, it is subdivided into several triangles under a rule that a channel segment results in a side of a triangle. These cases are processed automatically. In other cases, for example, when a grid has more than one channel segment in it, or a

grid has a confluence point, an upper end or a downstream end of a channel network in it, an operator interactively subdivides the grid into several triangles using a mouse device with watching the result of subdivision on a computer display.

### *2.2.3 Getting rid of pits*

A pit is a vertex whose surrounding vertices have higher elevation. If natural topography is so complicated to represent it by using a grid DEM with a current grid spacing, sometimes false pitting occurs. The program finds pits automatically and solves them by adding a new vertex and rearranging a triangle network by using it. An operator interactively locates a new vertex having appropriate elevation at an appropriate position and remakes a triangle network with referring a topographic map, using a mouse device and watching the result on a computer display. The procedure continues until no false pit exists.

### *2.2.4 Joining discontinuous valley segments to channel network*

In this stage of processing, valley segments which do not join a channel network exist in a TIN-DEM of a watershed basin. This means that it cannot be decided whether triangles which contribute to these valley segments are included in a study basin or not, because it is not determined whether these valley segments are connected to a channel network or not. Therefore, a valley segment which is connected to a channel network is searched. An algorithm for the procedure is as follows: a path of the steepest descent from the lowest end of a valley segment is traced until it reaches to either a channel network or the boundary of a study area. If the path reaches to a channel network, it is included in a channel network, and a triangle network is updated under a rule that each segment which makes up the path results in a side of a triangle.

### *2.2.5 Subdivision of triangles*

Most of the triangles have two sides through which water flows out. To identify source areas, these triangles must be subdivided into triangles which have only one out-flow-side through which water flows to an adjacent triangle. An algorithm for this procedure is as follows: a path of the steepest ascent is traced from a vertex, and coordinates of an intersection on an opposite side is computed. If the intersection is found on the opposite side, the intersection is stored in a vertex data set, and the adjacent triangles which have the side in common are subdivided into four triangles by using the intersection. The path is traced with subdividing triangles until it encounters a ridge segment or a boundary of a study area. This subdivision procedure is applied to all the vertices included in a study area, but it is not necessary to apply the procedure to new vertices added by this subdivision. Triangles which have two sides through which water flows in are also subdivided so that each triangle has only one in-flow-side. The procedure is the same as stated above except for tracing a path of the steepest descent from a vertex.

## *2.3 Watershed modeling by using TIN-DEMs*

Once the TIN-DEM data structure is generated, it is easy to define triangular facets which are placed at the upper part of an arbitrary triangle. Each triangle has only one adjacent triangle into which water flows, therefore triangles which contribute to a particular triangle are recursively searched. A channel network data set includes the information of triangles which are in contact with a channel network, so by applying the procedure to the triangles stored in a channel network data set, the triangles which form slope elements included in a study watershed can be automatically determined.

The system was applied to the Shirasaka experimental basin ( $0.88\text{km}^2$ ) in the Tokyo University Forest. The source data sets are a grid-DEM of 20m spacing and a DLG of a channel network obtained from a 1:2,500 scale topographic map. Figure 4 shows the automatically delineated watershed for the Shirasaka experimental basin. The number of slope elements which contribute to the channel network in the study area was 4,796. Thick solid lines represent the polygonal channel network and thin lines show the valley segments which are connected to the channel network.

For each slope element which contributes to a channel network segment (Figure 5), following topo-

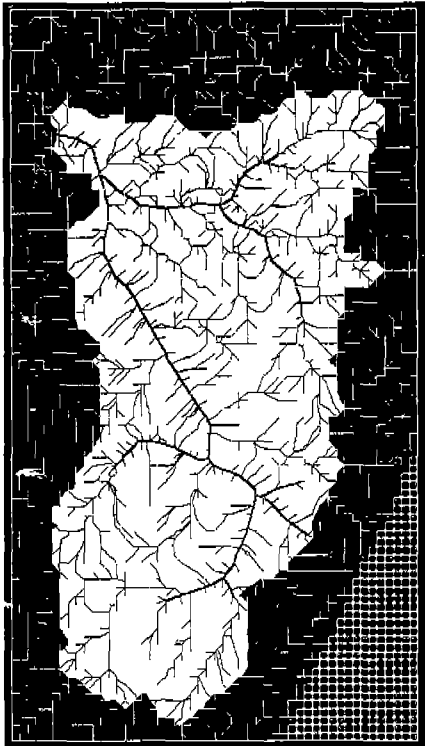

Figure 4: TIN-DEMs representation of the Shirasaka experimental basin.

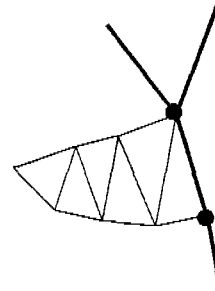

Figure 5: Extraction of a slope element which contributes to a channel network segment.

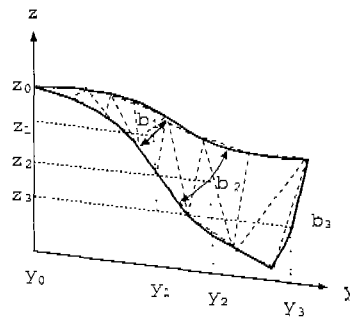

Figure 6: Approximation of a slope element by using cubic spline functions.

graphic attributes are computed: (1) area of each triangle included in a slope element; (2) area of a slope element; (3) the average gradient of a slope element; (4) the widths of a slope element, for example,  $b_1$ ,  $b_2$ ,  $b_3$  in Figure 6; and (5) the flow distances from the upper boundary, for example,  $y_1$ ,  $y_2$ ,  $y_3$  in Figure 6. Cubic spline functions which deal with a horizontal and vertical change of a slope shape are defined by using the values of the widths and flow distances respectively.

### 3 DISTRIBUTED RAINFALL-RUNOFF MODEL BASED ON TIN-DEMs

#### 3.1 Flow model

To deal with water movement on a slope element represented with spline functions, we use combined surface-subsurface kinematic wave equations considering a change of slope gradient and slope width (Takasao and Shiiba, 1988). Figure 7 shows a schematic drawing of a flow model on a slope element. A watershed surface is assumed to be covered with a highly permeable stratum, which we call A-layer, having a uniform thickness overlying an impermeable base. The infiltration rate of the A-layer is assumed to be always larger than rainfall intensity. If the depth of subsurface flow exceeds the depth of the A-layer, then from that point surface flow occurs. In the figure,  $x$  represents the distance from the upper boundary along the steepest descent,  $b(x)$  is the slope width at  $x$ ,  $\theta(x)$  is the slope gradient at  $x$ ,  $y$  is the distance projected on a horizontal plane,  $H$  is the depth of flow, and  $D$  is the depth of the A-layer.

Let  $q$  be discharge per unit width, the continuity equation considering a change of slope width and

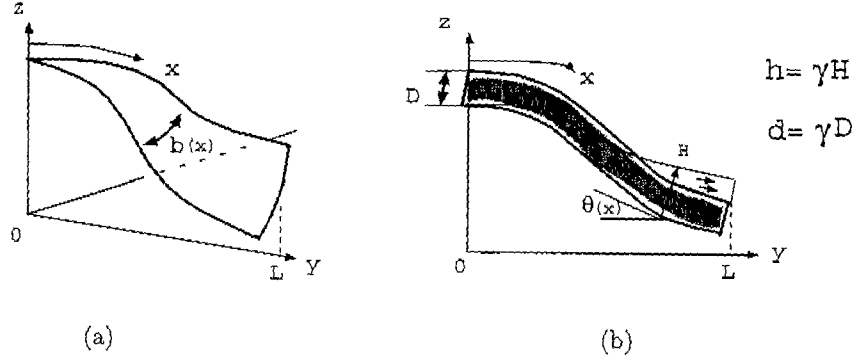

Figure 7: Schematic drawing of a flow model; (a) a quasi-three-dimensional shape of a slope element; (b) water flow movement on a slope element.

gradient can be written as

$$\frac{\partial h}{\partial t} + \frac{1}{b(x)} \frac{\partial}{\partial x} \{qb(x)\} = r(x, t) \cos(\theta(x)) \quad (1)$$

where  $h$  is apparent depth of flow defined as  $\gamma H$ ,  $\gamma$  is the effective porosity of the A-layer and  $r(x, t)$  is rainfall intensity. The momentum equations for only subsurface flow and for combined surface-subsurface flow can be written as

$$q = \frac{k \sin(\theta(x))}{\gamma} h, \quad \text{for } 0 \leq h \leq d \quad (2)$$

$$q = \frac{\sqrt{\sin(\theta(x))}}{n} (h - d)^m + \frac{k \sin(\theta(x))}{\gamma} h, \quad \text{for } h > d \quad (3)$$

where  $d$  is apparent depth of the A-layer defined as  $\gamma D$ ,  $k$  is the hydraulic conductivity of the A-layer,  $n$  is Manning's roughness coefficient and  $m = 5/3$ . The values of  $b(x)$  and  $\sin(\theta(x))$  at any point are easily computed from spline functions which represent a change of slope width and gradient, respectively. To get solution of the equations, the one-step Lax-Wendroff difference scheme is applied.

For each channel link, discharges from slope elements which contribute the link are computed and stored in computer memory, and they are routed to a basin outlet through a channel network with kinematic wave equations. To reduce a computer memory requirement of the program, the computation order to obtain discharges from channel links is appropriately determined by the algorithm described by Takasao and Shiiba (1976).

### 3.2 Runoff simulation

The simulated and observed hydrographs at the Shirasaka experimental basin are shown in Figure 8. In the figure, the solid hydrograph and dotted hydrograph are the results of runoff simulations when shapes of slope elements are represented with spline functions and rectangles respectively. The model parameters are determined to fit simulated discharge to observed one when the shapes of slope elements are approximated quasi-three dimensionally with spline functions. Except for a method to represent a shape of a slope element, both simulation conditions are the same. The determined model parameters are as follows: the depth of the A-layer is 50 cm,  $k = 1.4 \text{ cm s}^{-1}$ ,  $\gamma = 0.15$ ,  $n$  in slope elements =  $0.25 \text{ m}^{-1/3}$ ,  $n$  in a channel =  $0.05 \text{ s m}^{-1/3}$ , and initial loss of rainfall is 5 mm.

This result shows that the shape of each slope element gives a great impact on hydrologic response. When we use the model whose slope elements are represented as rectangular slopes, it is possible to turn the simulated hydrograph to the observed one, but the physical meaning of the model parameters may be lost. It is emphasized that accurate representation of natural landscapes is fundamental to construct a distributed rainfall-runoff model with physically sound soil properties.

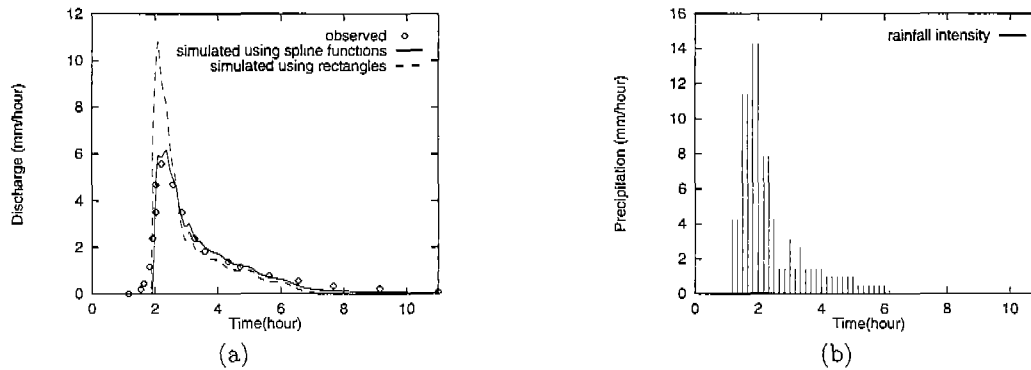

Figure 8: (a) Simulated and observed hydrographs. (b) Observed precipitation.

#### 4 EFFECT OF SPATIAL SOIL PROPERTIES ON RUNOFF RESPONSE

One of the subjects of distributed hydrological modeling is how to evaluate many distributed model parameters such as soil thickness, hydraulic conductivity, porosity, surface roughness characteristics. Usually, to obtain values of these parameters from generally available spatial data sets is difficult. In Japan, soil information has not been mapped or the spatial resolution of available soils information is far coarser than topographic information. Therefore, such parameters often must be inferred from observed rainfall and discharge data sets, however it is quite difficult to estimate spatial distributions of model parameters from only observed hydrological data sets.

One of the methods to cope with the problem is to investigate the influence of spatial distributions of model parameters on rainfall-runoff simulation results. A knowledge about what information of model parameters has dominant effects on runoff simulation will be useful to determine model parameters.

##### 4.1 Simulation method

A set of values of a soil parameter, in this case, hydraulic conductivity, is generated according to log normal distribution. Each value is assigned to each slope element, and runoff is simulated by using the distributed rainfall-runoff model described at the above sections. Next, the values of the soil parameter are randomly shuffled for their locations; each value is assigned to each slope element; and runoff is simulated again. The procedures are repeated and simulated hydrographs are compared. Figure 9 shows a schematic drawing of the simulation method. If these simulated hydrographs are quite similar, it means that spatially explicit soil information is not so important.

##### 4.2 Results and discussions

Eight cases of simulations were carried out (the results of three cases are shown in Figure 10). In all cases, the values of hydraulic conductivity  $k$ , were generated according to log normal distribution. For each case, mean value was fixed to 1.4 cm/sec, and standard deviation was set to 0.1, 0.3, 0.5, 5.0, 10.0, 30.0, 50.0, 100.0 cm/sec, respectively. Values of other parameters were fixed with spatially uniform values. Rainfall intensity was set to 5.0 mm/hr with spatially uniform.

In each hydrograph of Figure 10, five kinds of simulated discharges are drawn. On the five simulated discharges, the values of mean and standard deviation of hydraulic conductivity in the study area are same, but the spatial arrangements of parameter values are different. Figure 11 shows the differences between hydrographs when we set different values of standard deviation and Figure 12 shows the differences between time series of areal ratio of surface flow occurrence. From these figures, we see that the differences of standard deviation of hydraulic conductivity change the flow form and simulated discharges, however the differences of the spatial arrangements of parameter values do not change the simulated discharges. This means that the values of mean and variance of hydraulic conductivity within a watershed are the

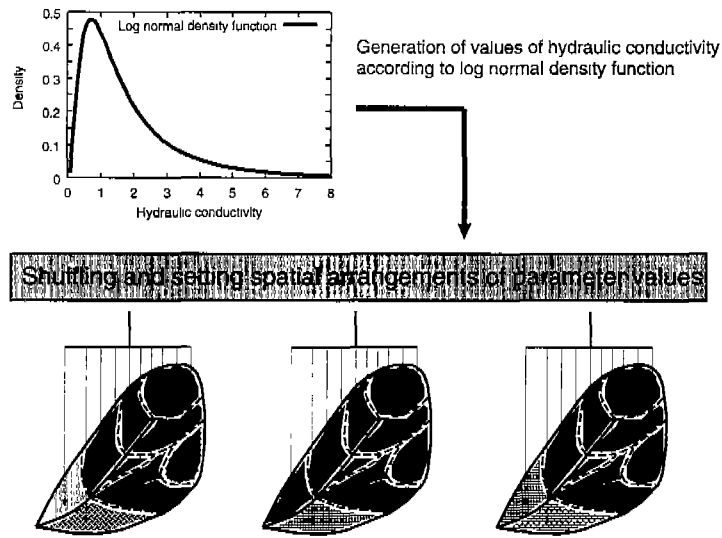

Figure 9: Simulation method.

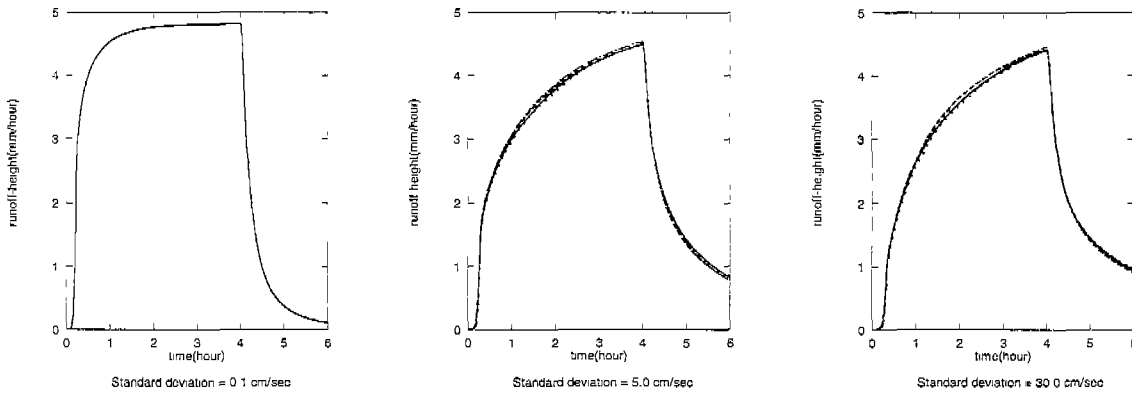

Figure 10: Comparison of simulated hydrographs. In each figure, five simulated hydrographs are drawn. On the five hydrographs, locations of assigned hydraulic conductivity values are different, but the values of mean and variance in the study area are same. In all cases, hydrographs are quite similar.

most important information for the runoff simulations. On the values of soil thickness  $D$ , same kinds of simulations were conducted, and similar results were obtained.

## 5 CONCLUSIONS

A TIN-based watershed modeling method and a distributed rainfall-runoff model using the topographic representation were presented. The watershed modeling method allows us to partition a catchment considering the direction of water flow for dealing with water movement one-dimensionally and approximate a partitioned catchment to a slope element of a quasi-three-dimensional shape by using cubic spline functions. To deal with water movement on the slope elements, combined surface-subsurface kinematic wave equations considering a change of slope gradient and slope width were applied.

The model is a useful tool to examine the effect of spatial variability of topography, soil properties.



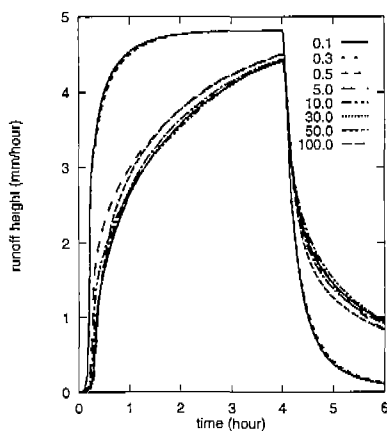

Figure 11: Differences among hydrographs due to differences of the variance of hydraulic conductivity.

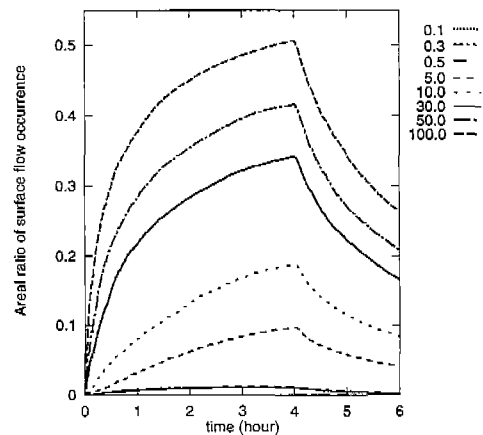

Figure 12: Differences among areal ratio of surface flow occurrence in the study area due to differences of the variance of hydraulic conductivity.

and rainfall intensity on runoff characteristics. The model is applied to the Shirasaka experimental basin ( $0.88\text{km}^2$ ) in the Tokyo University Forest in Japan, and the effects of spatial variability of soil properties on runoff characteristics are examined. As a preliminary result, we obtained that spatially lumped distribution information (mean and variance) of soil parameters within a watershed is the most important information and spatially explicit soils information is not always needed under spatially uniform rainfall condition. If so, we may identify the mean and variance of soil parameters by postulating the distribution function of soil parameters. Now, we continue a research to examine the effects of spatial variability of hydrologic variables on simulated discharges for a larger watershed giving spatially distributed rainfall to distributed rainfall-runoff models.

## REFERENCES

- Moore, I. D., Grayson, R. B. and Ladson, A. R. (1991). "Digital terrain modelling : a review of hydrological, geomorphological and biological applications." *Hydrological Processes*, 5(1), pp. 3-30.
- Moore, I. D. and Grayson, R. B. (1991). "Terrain-based catchment partitioning and runoff prediction using vector elevation data." *Water Resources Research*, 27(6), pp. 1177-1191.
- Tachikawa, Y., Shiiba, M. and Takasao, T. (1994). "Development of a basin geomorphic information system using a TIN-DEM data structure." *Water Resources Bulletin*, 30(1), pp. 9-17.
- Tachikawa, Y., Takasao, T. and Shiiba, M. (1996). "TIN-based topographic modeling and runoff prediction using a basin geomorphic information system." *HydroGIS 96: Application of Geographic Information Systems in Hydrology and Water Resources Management*, IAHS Publ., 235, pp. 225-232.
- Tachikawa, Y., Vieux, E. B., Shiiba, M. and Takara, K. (1999). "How important is spatially explicit soil information for a distributed rainfall-runoff model?" *EOS Transactions*, AGU, Spring Meeting, 80(17), S159.
- Takasao, T. and Shiiba, M. (1988). "Incorporation of the effect of concentration of flow into the kinematic wave equations and its applications to runoff system lumping." *J. of Hydrology*, 102, pp. 301-322.
- Takasao, T. and Shiiba, M. (1976). "A study on the runoff system model based on the topographical framework of river basin (in Japanese)." *Proc. of Japan Society of Civil Engineers*, 248, pp. 69-82.