

## 지진 격리된 교량의 내진성능에 대한 실험적 연구

### Experimental Study on Seismic Performance of Base-Isolated Bridge

Chung, Woo-Jung\* Yun, Chung-Bang\*\* Kim, Nam-Sik\*\*\* Seo, Ju-Won\*\*\*

---

#### ABSTRACT

Base isolation is an innovative design strategy that provides a practical alternative for the seismic design of structures. Base isolators, mainly employed to isolate large structures subjected to earthquake ground excitations and to rehabilitate structures damaged by past earthquakes, deflect and absorb the seismic energy horizontally transmitted to the structures. This study demonstrates that the base isolation system may offer effective performance for bridges during severe seismic events through shaking table tests. Two base isolation systems using laminated rubber bearings with and without hydraulic dampers are tested. The test results strongly show that the laminated rubber bearings cause the natural period of the bridge structure increased considerably, which results in the deck acceleration and the shear forces on the piers reduced significantly. The results also demonstrate that the hydraulic dampers enhance the system's capacity in dissipating energy to reduce the relative displacement between the bridge deck and the pier.

---

**Key Words :** *Base-isolated Bridge, Shaking Table Test, Laminated Rubber Bearing, Hydraulic Damper*

#### 1. INTRODUCTION

In recent years, enormous social and economic disasters occurred during strong earthquake events such as Northridge(1994) and Hyogoken Nambu(1995) earthquakes. Therefore, considerable efforts have been made to improve the earthquake resistant design procedures for structures all over the world. In Korea, after Yongweol earthquake with magnitude of 4.5 in Richter scale occurs in December 13, 1996, the public interest in the safety of large public structures during seismic events has been increased significantly.

Base isolation is a relatively new design strategy that provides an attractive alternative for seismic design and retrofit of large structures. The role of the base isolator under seismic loading is to isolate the structure from the horizontal components of the earthquake ground movement, while the vertical component is transmitted to the structure relatively unchanged. The base isolator deflects and absorbs the seismic input energy horizontally transmitted to the structures. However, in spite of the energy dissipation capacity associated with the hysteretic behavior of the base isolator, the displacement

---

\* Daewoo Engineering Company

\*\* Department of Civil Engineering, Korea Advance Institute of Science and Technology

\*\*\* Hyundai Institute of Construction Technology

response of the base isolated structure increases significantly due to the flexibility of the base isolator. There have been lots of research activity to improve the energy dissipation capacity of the base isolation system by using the energy dissipation devices such as lead extrusion damper, sliding friction damper, sliding pendulum damper, and hydraulic damper. Hydraulic dampers, which operate on the principle of viscous fluid flow through orifices, were frequently used for the shock isolation of military hardware. However, from the early 1960's, they were introduced to industrial applications including the seismic isolation of large structures.

In this study, laminated rubber bearings are employed to reduce the seismic responses of the bridge structure, particularly the deck acceleration, the shear force and overturning moment on the piers. On the other hand, fluid viscous dampers are utilized to reduce the relative displacement between the bridge and the piers. A series of experiments are conducted on a 1/5 scale bridge model on a shaking table subjected to various seismic loads. The main objectives are (1) evaluation of the effectiveness of the laminated rubber bearing for the base-isolation bridge, and (2) investigation of the effectiveness of the hydraulic damper. It is essential to conduct shaking table tests on the base isolated structure, since the inelastic behavior of the base isolation system, particularly the velocity dependent characteristic of the hydraulic damper, is too complicated to be represented by a simple numerical model.

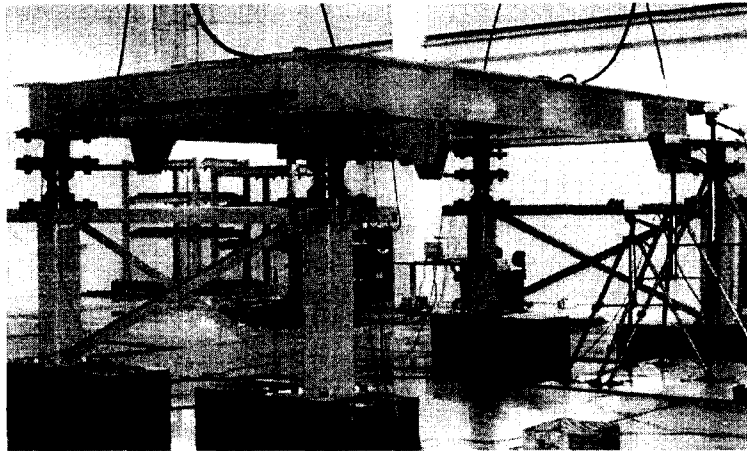

(a) Overview of Test Structure

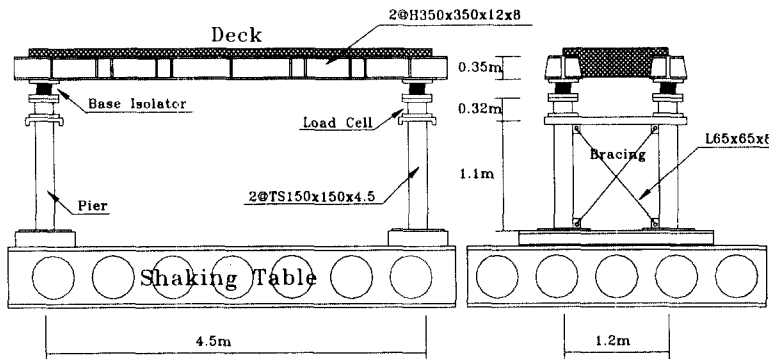

(b) Dimensions of Test Structure

Figure 1 Test Structure on Shaking Table

## 2. MODELS FOR SHAKING TABLE TESTS

### ***Bridge Deck and Piers***

A bridge deck model with two flexible piers is used for the shaking table tests as shown in Figure 1. The test structure represents an idealized model for a 3-span continuous steel plate girder section of the Mapo Bridge over Han River in Seoul, Korea. It is an un-isolated bridge. However, the present study on a 1/5 scale model is carried out for two cases of the isolated model as well as an un-isolated case. The first natural period of the Mapo Bridge (un-isolated) in the longitudinal direction is obtained as 0.42 sec. Hence the un-isolated test structure is designed to have the first natural period of 0.19sec following the similitude relationship for the 1/5 scale model. Structural properties of the bridge model as listed in Table 1.

### ***Laminated Rubber Bearings***

The design guides for base-isolated bridges by the American Association of State Highway Transportation Officials (AASHTO, 1991) are used for a preliminary design of the base isolator in this study, because no relevant design guidelines are available in the Korea seismic design codes for bridges. In the AASHTO specifications, the elastic seismic force coefficient  $C_s$  is specified as

$$C_s = \frac{AS_i}{T_e B} \leq 2.5A \quad (1)$$

where  $A$  = the acceleration coefficient,  $S_i$  = the site coefficient,  $B$  = the damping coefficient for the isolation system, and  $T_e$  = the effective natural period of the base isolated bridge which can be obtained as

$$T_e = 2\pi \sqrt{\frac{W}{g \sum K_{eff}}} \quad (2)$$

Then the total base shear forces on the piers  $V$  can be computed as

$$V = C_s W = \sum K_{eff} D_i \quad (3)$$

where  $W$  = the weight of the superstructure,  $\sum K_{eff}$  = the sum of the effective linear springs for all isolation bearings supporting the superstructure segment, and  $D_i$  = the displacement of the base isolator which can be determined from Eqs (1)-(3) as

$$D_i = \frac{AS_i T_e}{4\pi^2 B} g \quad (4)$$

In this study, the acceleration coefficient ( $A$ ) and the site coefficient ( $S_i$ ) at the bridge site are assumed to be 0.14 and 2.0, respectively, and the target elastic seismic force coefficient ( $C_s$ ) is taken as 0.15 for the base-isolated bridge. Assuming  $B$  is equal to 1.2 which is equivalent to a damping ratio ( $\xi$ ) of 0.10, the effective natural period of the base isolated bridge ( $T_e$ ) can be obtained as 1.55 sec and 0.69 sec for the prototype and the scale structure, respectively. Then, the design displacement of the base isolator ( $D_i$ ) is estimated as 96.2mm for the prototype, and 19.3mm for the scaled model. Finally the design effective stiffness of each base isolator can be evaluated as :

$$K_{eff} = \frac{4\pi^2 W}{ngT_c^2} \quad (5)$$

where  $n$  = the number of base isolators.

For a case with 4 base isolators, the effective stiffness of a base isolator is determined as 2.16kN/cm. The horizontal stiffness of a base isolator can be evaluated as

$$K_{eff} = \frac{GA_b}{t_r} \quad (6)$$

where  $G$  is the shear modulus of the rubber,  $A_b$  is the bonded area of the rubber bearing, and  $t_r$  is the total thickness of the rubber layers. The shear modulus for the rubber for the LRB decreases as the shear strain increases, and the value is typically in the range of 0.7~1.2Mpa. However it is taken as 0.9 MPa in the preliminary design considering the relative large shear strain level expected during the design earthquake event. By taking the outer and inner diameters of the laminated rubber bearing as 14.2 and 3 cm respectively, the total thickness of the rubber layers ( $t_r$ ) required for  $K_{eff}$  to be 2.16 kN/cm is obtained as 64mm. The dimensions of the laminated natural rubber bearing designed and manufactured in accordance with the above procedures are shown in Figure 2.

In Table 1, the natural period of the scaled model is compared with the measured one during the shaking table tests with white noise excitation. The measured period is found to be smaller than the estimated in the preliminary design. It is due to the fact the value of  $G$  of the rubber is higher for the case of the vibration tests with small amplitudes than the value assumed in the design.

Table 1 Structural Properties of Bridge Models

Cases		Prototype	Scaled Model
Deck Weight (kN)		12740	102
Stiffness of a Pier (kN/cm)		2956	119
Stiffness of a LRB (kN/cm)		-	2.16* (3.15)**
Natural Period (sec)	Un-Isolated	0.42	0.19
	Isolated	1.55* (1.27)**	0.69* (0.57)**

Note : \* The values are from the preliminary design.

\*\* The values in parentheses are the measured ones during the test using white noise excitation.

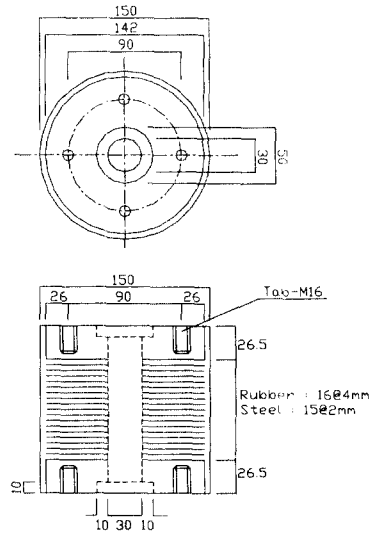

Figure 2 Dimension of Natural Rubber

### Hydraulic Dampers

In recent years, hydraulic dampers which were widely used in aerospace and military applications have been incorporated into civil engineering structures. The hydraulic damper is a device, which dissipates energy by applying a resisting force over a finite displacement. The damper's output force is resistive, therefore it acts in a direction opposite to that of the input motion. The force generated by the fluid damper is due to a pressure differential across the piston head. In case the piston moves from left to right, the fluid flows from the right chamber towards the left chamber. Then, the fluid volume is reduced by the amount which is a product of the travel of the piston and the piston rod area. Since the fluid is compressible, this reduction in fluid volume may cause the development of an un-desired restoring force, which may be prevented by using an accumulator. If the exciting frequency is below a certain frequency, which is related to the characteristics of the accumulator valves, the hydraulic damper acts mainly as a viscous damper.

The maximum displacement and the damping force of the hydraulic damper used in this study are  $\pm 50\text{mm}$  and  $4.45\text{kN}$ , respectively. The damping ratio ( $\xi$ ) is approximately in the range 15 – 30% of the critical damping value. However the overall damping ratio of the isolated bridge with the hydraulic dampers are approximately taken as 20% in the preliminary design. Then, the maximum damping force can be calculated by

$$F_D = C \times v_{\max} \quad (7)$$

where  $v_{\max}$  is the maximum velocity response which may be taken to be equal to the spectral velocity ( $S_V$ ), and  $C$  is the damping coefficient of the structure as

$$C = 4\pi\xi \frac{W}{gT_c} \quad (8)$$

where  $W$  is the total weight of the bridge deck and  $T_c$  is the natural period of the base-isolated structure. The spectral velocity is related to the spectral displacement  $S_D$  as

$$S_V = \omega S_D \quad (9)$$

Thus, the required damping force of a hydraulic damper can be obtained from Eqs (7)-(9), which results in  $2.2\text{kN}$  for the test model.

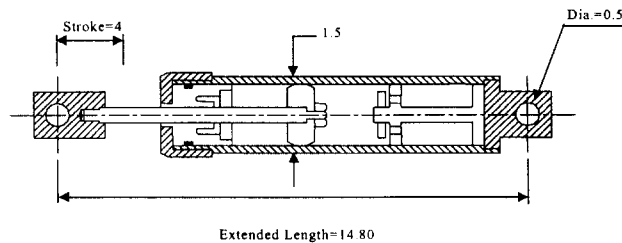

Figure 3 Hydraulic Damper

### ***Instrumentation***

Shaking table tests are carried out using the uni-directional shaking table facility at Large-Scaled Structural Testing Laboratory, Hyundai Institute of Construction Technology. The dimension of the table is 5m by 3m, and the maximum payload is 30 ton. The shaking table can vibrate in a horizontal direction by a hydraulic actuator with the maximum acceleration of 1g and the maximum stroke and piston velocity of 100mm and 50cm/sec, respectively. The foundation block of the shaking table is supported by three air springs in order to isolate the neighboring facilities and structures from the vibration of the shaking table. The dead weights of the table and the test structure are carried on by four hydraulic bearings, so that the actuator simulating the seismic acceleration does not carry the gravity loads.

The test structure is instrumented with a combination of accelerometers, position sensors and force transducers to record the responses of the structure to all input loads. The force transducers are used to record the axial forces and shear forces immediately below the rubber bearings. The position sensors are light spot position detectors, from which the deck displacements relative to the piers and the shaking table can be measured in two horizontal directions. A total of 26 channels of data are recorded for each test; 4 channels for the shaking table responses and 22 channels for the model responses. The dimensions of the test structure and the experimental setup are shown in Figure 1.

### **3. RESULTS OF SHAKING TABLE TESTS**

At first, Ambient vibration tests were carried out using white noise excitation to evaluate the natural period and damping of the two base isolated structures with LRB's only and LRB's with hydraulic dampers. The frequency response functions obtained for two cases are shown in Figure 4. The natural frequency of the isolated case with the LRB's only is obtained as 1.75 Hz, and the viscous damping ratio is estimated directly as 7.7%. In this case, the effective stiffness of a base isolator is evaluated as 3.15 kN/cm, which is considerably greater than the design value of 2.16 kN/cm. The larger stiffness in the test result is associated with the smaller shear strain than the strain level assumed in the preliminary design. The test results indicate that the damping ratio and the natural frequency increase significantly if the hydraulic dampers are added.

The effectiveness of the base isolation system using the laminated rubber bearings and the hydraulic dampers is evaluated for various earthquake inputs through shaking table tests. A total of 8 earthquake simulation tests are performed on the isolated bridge model. The earthquake signals consist of 4 recorded earthquakes and 4 artificial motions compatible with the Korean bridge design spectra for ground conditions I (rock and stiff soils), II (deep cohesionless or stiff clay soils), III (soft to medium clays and sands) and IV (deep soft clays or silts). Each input signal is compressed in time by a factor of  $\sqrt{5}$  to satisfy the similitude requirements for the 1/5 scale model.

Figure 5 compares the deck acceleration responses of the un-isolated bridge, the isolated bridge by LRB's only, and the isolated bridge by LRB's and hydraulic dampers under El Centro earthquake. Figure 6 shows the deck displacements relative to the ground for three bridge cases. It can be observed that the deck accelerations of the isolated bridges which are directly related to the shear forces on the piers decrease substantially compared with those of the un-isolated bridge. On the other hand, the deck displacements increase significantly. Figure 7 illustrates that the maximum deformations of the

isolated bridge piers are 2.1 and 2.8mm for two isolated bridges, which are about 1/10 and 1/4 of the maximum deck displacements, respectively. This indicates that the base isolators have to take most of the additional displacement. The excessive relative displacement of the deck may cause falling of the girders and colliding with the abutments. Therefore, the hydraulic dampers are employed to control the substantial displacement in this study. Figure 6 depicts that the hydraulic dampers can reduce the displacement of the isolated bridge. The maximum displacement of the isolated bridge deck with the LRB's only is 20.2mm, which is about 3 times of the maximum response of the un-isolated bridge (6.5mm). However, if the hydraulic dampers are added, the maximum response reduces to 11.8mm. As shown in Figure 5, the deck acceleration of the isolated bridge increases slightly, though the dampers are added.

In Figure 8, the force-displacement relationships for El Centro earthquake input are shown for two isolated cases. The effective stiffness of a base isolator is estimated as 2.25 kN/cm and the equivalent viscous damping ratio is evaluated as 10% for the case with LRB's only. On the other hand, for the case with LRB's and hydraulic dampers, those values increase to 3.25 kN/cm and 32%, respectively. Again it can be seen that the stiffness of the base isolator varies with the shear strain level.

Table 2 shows the maximum deck accelerations for three bridge cases subjected to various ground motions, while Table 3 compares the maximum deck displacements. The results demonstrate that significant benefits can be obtained from the isolation systems. The accelerations reduce approximately to the 1/2 levels, except for the case of Mexico City earthquake. Under Mexico City earthquake, the acceleration increases 1.5 times and the displacement increases as much as 8 times due to the base isolation. The responses of the isolated bridges subjected to the artificial earthquakes compatible to the Korean bridge design spectra for various soil conditions show that the merit of the base isolation becomes less significant as the soil condition becomes softer. Table 3 shows that the deck displacement can be reduced effectively by adding the hydraulic dampers to the base isolation system with LRB's.

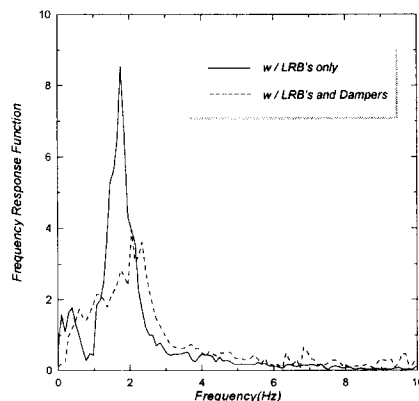
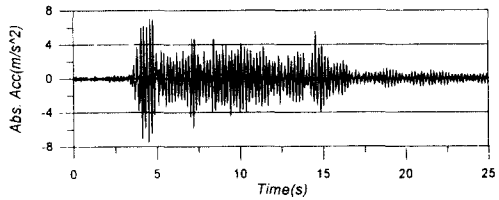
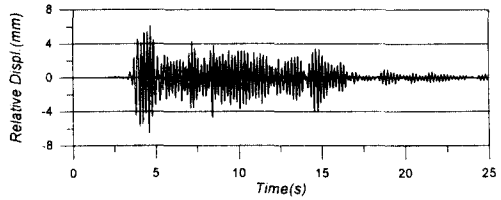

Figure 4 Frequency Response Functions for Deck Acceleration of Isolated Bridges from the Test Results Using White Noise Excitation



(a) Un-Isolated Bridge



(a) Un-Isolated Bridge

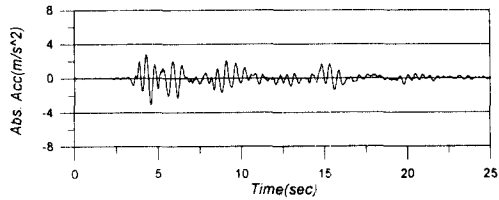

(b) Isolated w/ LRB's only

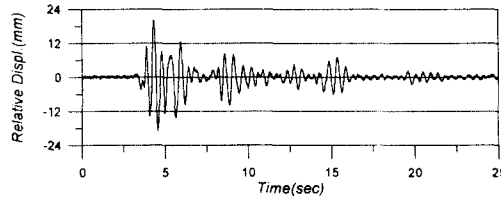

(b) Isolated w/ LRB's only

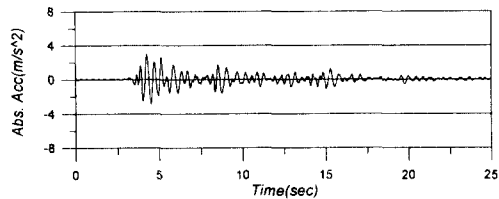

(c) Isolated w/ LRB's and Dampers

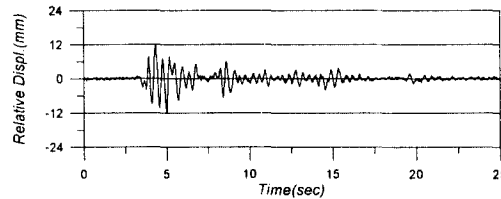

(c) Isolated w/ LRB's and Dampers

Figure 5 Deck Accelerations Under El Centro Earthquake

Figure 6 Deck Displacements Relative to the Ground Under El Centro Earthquake

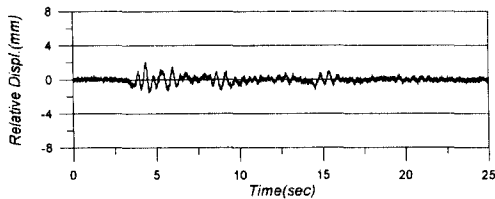

(a) Isolated w/ LRB's only

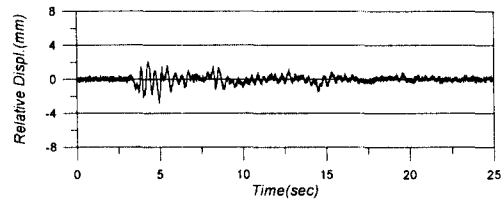

(b) Isolated w/ LRB's and Dampers

Figure 7 Displacements of Pier Relative to the Ground under El Centro Earthquake

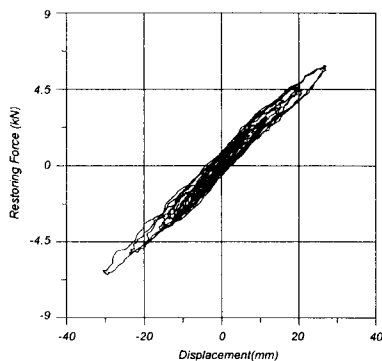

Table 2 Maximum Accelerations of Bridge Deck Subjected to Various Inputs

Inputs	PGA (g)	Maximum Deck Accelerations (g)		
		Un-Isolated	Isolated	Isolated
		Bridge	w/ LRB's only	w/ LRB's and Dampers
El Centro	0.41	0.76	0.32	0.34
Taft	0.23	0.52	0.16	0.18
Hachinohe	0.15	0.49	0.33	0.21
Mexico City	0.17	0.20	0.31	0.25
Korean B.C. I	0.22	0.54	0.20	0.19
Korean B.C. II	0.22	0.63	0.20	0.20
Korean B.C. III	0.24	0.57	0.27	0.32
Korean B.C. IV	0.31	0.82	0.34	0.34

Table 3 Maximum Displacements of Bridge Deck Relative to the Ground Subjected to Various Inputs

Inputs	Un-Isolated	Isolated	Isolated	(b)/(a)
	Bridge	w/ LRB's only (a)	w/ LRB's and Dampers (b)	
	(mm)	(mm)	(mm)	
El Centro	6.5	20.2	11.8	0.59
Taft	4.1	8.8	5.6	0.63
Hachinohe	5.2	17.4	8.6	0.49
Mexico City	2.5	20.9	13.14	0.63
Korean B.C. I	3.6	7.3	3.4	0.46
Korean B.C. II	5.6	10.2	5.8	0.56
Korean B.C. III	4.3	13.9	8.2	0.59
Korean B.C. IV	4.3	15.8	10.2	0.65



(a) Isolated w/ LRB's only

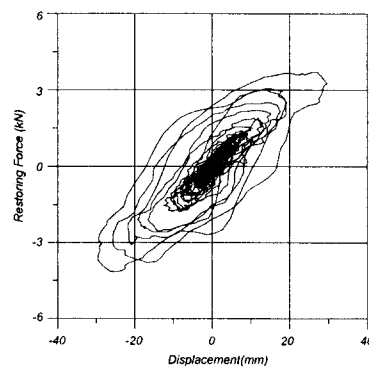

(b) Isolated w/ LRB's and Dampers

Figure 8 Force-Displacement Relationship of a Base Isolator

#### 4. CONCLUSIONS

A series of the shaking table tests were conducted on a bridge supported by the base isolation systems using laminated rubber bearings and hydraulic dampers under various earthquake loading. The shaking table test results strongly show that the base isolation is a very effective way to reduce the seismic response of the bridge, particularly deck acceleration and shear force of piers at rock or rock-like soil sites. However, at soft soil sites, it is less effective. For instance, at extreme soft soil sites like Mexico City, both the acceleration and the displacement responses of the isolated bridge may be considerably amplified. Though the seismic force in the bridge can be reduced effectively by the base isolation technique, the amplification of the displacement response must be considered in the design procedure. The effectiveness of the hydraulic dampers as a part of the seismic isolation system has been also studied. The shaking table test results show that the hydraulic dampers can enhance the system's ability to dissipate energy resulting in significant reduction of the relative displacement between the bridge deck and the piers.

#### REFERENCES

1. AASHTO "Guide Specification for Seismic Isolation Design", *American Association of State Highway and Transportation Officials*, Washington, D. C., 1991
2. Kelly, J. M. "Seismic Base Isolation: Review and Bibliography", *Earthquake Engineering and Structural Dynamics*, Vol. 5, No. 3, 1986, 202-216.
3. Buckle, I. and Mayes, R. "Seismic Isolation: History, Application, and Performance-A World View", *Earthquake Spectra*, Vol. 6, No. 2, 1990, 161-201.
4. Fujita, T., et al, "Research, Development and Implementation of Rubber Bearings for Seismic Isolation", *Pressure Vessels and Piping Conference, ASME*, vol. 181, Hawaii, 1989, 35-42
5. Constantinou, M. C., and Symans, M. D., "Experimental and Analytical Investigation of Seismic Response of Structures with Supplemental Fluid Viscous Dampers", *National Center for Earthquake Engineering Research*, Report No. NCEER-92-0032, Buffalo, New York, 1992.
6. Tsopelas, P., Constantinou, M. C., Okamoto, S., Fujii, S., and Ozaki, D., "Experimental Study of Bridge Seismic Sliding Isolation Systems", *Engineering Structures*, Vol. 18, No. 4, 1996, 301-310.
7. Chung, W. J., "Experimental Study on Seismic Performance Improvement of Structures Using Base Isolation Techniques", *Ph. D. Thesis. Korea Advanced Institute of Science and Technology*, 1998.
8. Kim, N. S., and Lee, D. G., "Pseudo-Dynamic Tests for Evaluation of Seismic Performance of Base-Isolated Liquid Storage Tanks", *Engineering Structures*, Vol. 17, No. 3, 1995, 198-208
9. Yun, C. B., Chung, W. J., Kim, N. S., and Kim D. H., "Experimental Techniques for Evaluating Seismic Performance of Base-Isolated Structure", *Journal of the Earthquake Engineering Society of Korea*, Vol. 1, No. 4, 1997 (in Korean)
10. Chung, W. J., Yun, C. B., Kim, N. S., and Seo, J. W., "Shaking Table and Pseudodynamic Tests for the Evaluation of the Seismic Performance of Base-Isolated Structures", *Engineering Structures*, in press