

허동영, 김학성, 조규형
한국과학기술원 전기및전자공학과

NEW GROUP OF ZVS PWM CONVERTERS OPERABLE ON
CONSTANT FREQUENCY AND ITS APPLICATION TO
POWER FACTOR CORRECTION CIRCUIT

Dong Y. Huh, Hack S. Kim and Gyu H. Cho

Dept. of Electrical Engineering, Korea Advanced Institute of Science and Technology

ABSTRACT

A new zero voltage switching PWM converter family is presented by using a new ZVS PWM module (ZPM) with a saturable inductor which prevents diode junction capacitors and a commutation inductor from resonating. The new converters show almost all characteristics of the conventional PWM converters. A boost ZVS PWM converter is applied to a power factor correction circuit. It operates on a continuous conduction mode. Experimental results for output power of 1kW are presented.

I. INTRODUCTION

In recent power processing circuit, soft switching techniques have been adopted to increase switching frequencies and, thus, to reduce the overall equipment weight, volume and cost. In ZCS or ZVS resonant converters of which resonant elements play the major roles of energy storage and transfer, current or voltage stresses of semiconductor devices become high, which prevent them from applying to a high power system [1-2]. Many soft switching converters are controlled by varying their switching frequencies, which makes the filter design be difficult and increases complexity of their control circuits [3-5].

In this paper a new ZVS PWM module having the features of soft switching and PWM control with low voltage and current rating is suggested. ZVS PWM converter family operable on constant frequency is constructed by replacing the switches of the conventional PWM DC/DC converters with the proposed ZVS PWM module. Finally the boost ZVS PWM converter is applied to a power factor correction circuit operating on continuous conduction mode.

II. ZERO VOLTAGE SWITCHING
PWM MODULE (ZPM)

Zero voltage switching PWM module (ZPM) consists of two semiconductor switches Q1 and Q2, two diodes D1 and D2, and commutation components L_r and C_r , as shown in Fig. 1. The saturable inductor L_s does not participate in the commutation process, however, it is very important at the final stage of commutation to reduce the reverse recovery problem of the diodes D1, and D2 because they turn off at zero current condition, which will be described in more detail in chapter IV. Q1 and Q2 perform zero current turn-on and zero voltage turn-off. Q1 and Q2 are switched at the same time with constant switching frequency. The commutation time of ZPM is short enough to enable the

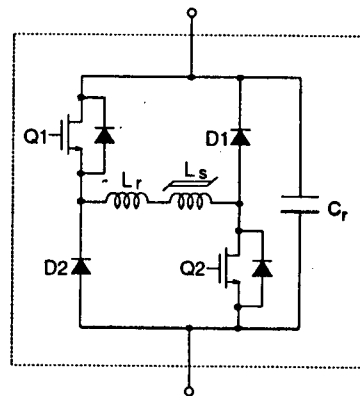

Fig. 1 ZVS PWM module

output voltage to be controlled by duty ratio. All the switches and diodes have the same peak voltage ratings as in the hard switching PWM converters. The switches in the hard switching PWM converters can be replaced directly by the proposed switch module without modifying any circuit configuration.

III. PRINCIPLE OF OPERATION

A boost converter using ZPM is formed as shown in Fig. 2. To analyze the steady state circuit behavior, the following assumptions are made :

- $L_{in} \gg L_r$
- L_s is neglected.
- Input voltage and L_{in} are treated as a DC current source and output filter capacitor is regarded as a DC voltage source.
- Semiconductor devices are ideal.
- Reactive elements are ideal.

The following variables are defined :

- Resonant angular frequency $\omega_r = 1/\sqrt{L_r C_r}$
- Characteristic impedance $z_r = \sqrt{L_r/C_r}$

A switching cycle can be divided into six modes and their associate equivalent circuits are shown in Fig. 3. Suppose that before Q1 and Q2 are turned on, diode D3 carries the input current I_{in} and capacitor v_c is clamped to V_o . At the beginning of a switching cycle, $t=t_0$, Q1 and Q2 are turned on simultaneously.

Mode 1 ($t_0 \leq t \leq t_1$)

Inductor current i_L rises linearly while the capacitor vol-

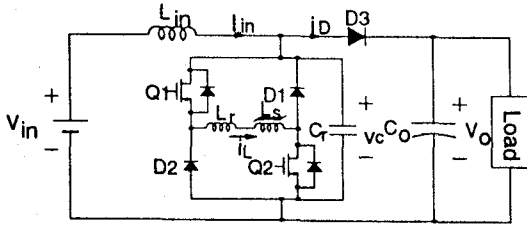

Fig.2 The boost ZVS PWM converter

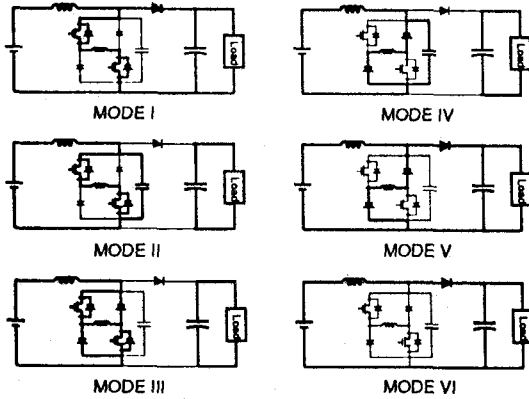

Fig.3 Topological mode diagram

tage is kept to V_o as follows :

$$i_L(t) = \frac{V_o}{L_r} t \quad (1)$$

During this mode, the current flowing through D3, i_D , decreases linearly as following equation :

$$i_D(t) = I_{in} - \frac{V_o}{L} t \quad (2)$$

When i_L reaches I_{in} , D3 is turned off and this mode is terminated. The duration of this mode, T_1 , is obtained from the condition of $i_L(T_1) = I_{in}$:

$$T_1 = t_1 - t_0 = \frac{L_r \cdot I_{in}}{V_o} \quad (3)$$

Mode II ($t_1 \leq t \leq t_2$)

L_r and C_r resonate as follows :

$$i_L(t) = I_{in} + \frac{V_o}{z_r} \sin \omega_r t \quad (4)$$

$$v_c(t) = V_o \cos \omega_r t \quad (5)$$

v_c decreases resonantly to zero. Then diode D1 and D2 are turned on and this mode is completed. The duration of this mode, T_2 , can be obtained from the condition of $v_c(T_2) = 0$:

$$T_2 = \frac{\pi}{2 \omega_r} \quad (6)$$

Mode III ($t_2 \leq t \leq t_3$)

The capacitor voltage v_c is kept zero while input current I_{in} flows through Q1, L_r and Q2 and the increment of the inductor current i_L during mode II freewheels through Q1-D1 and Q2-D2. During this mode the inductor current i_L remains as follows :

$$i_L(t) = I_{in} + \frac{V_o}{z_r} \quad (7)$$

The duration of this mode is set by the PWM controller. By turning off Q1 and Q2 simultaneously at zero voltage condition, this mode ends.

Mode IV ($t_3 \leq t \leq t_4$)

L_r and C_r resonates as follows :

$$i_L(t) = (2I_{in} + \frac{V_o}{z_r}) \cos \omega_r t - I_{in} \quad (8)$$

$$v_c(t) = (2I_{in} z_r + V_o) \sin \omega_r t \quad (9)$$

v_c increases resonantly. When v_c reaches V_o , D3 turns on at zero voltage condition and this mode finishes. The duration of mode IV, T_4 , can be calculated from the condition of $v_c(T_4) = V_o$:

$$T_4 = \sqrt{L_r C_r} \sin^{-1} \left(\frac{V_o}{2I_{in} z_r + V_o} \right) \quad (10)$$

At the end of this mode the inductor current i_L becomes from (8) and (10):

$$I_4 = i_L(T_4) = 2I_{in} \sqrt{1 + \frac{V_o}{I_{in} z_r}} - I_{in} \quad (11)$$

Mode V ($t_4 \leq t \leq t_5$)

i_L flows through D1, D2 and D3 and decreases linearly as following fashion:

$$i_L(t) = I_4 - \frac{V_o}{L_r} t \quad (12)$$

During this mode, v_c remains V_o . When i_L drops to zero, D1 and D2 are turned off at zero current condition and this mode ends. The duration of this mode, T_5 , is calculated from the condition of $i_L(T_5) = 0$:

$$T_5 = \frac{L_r I_4}{V_o} \quad (13)$$

Mode VI ($t_5 \leq t \leq t_0$)

During this mode ZPM stops its operation and diode D3 carries the input current I_{in} to the output as in the case of the PWM boost converter. When Q1 and Q2 turns on simultaneously at zero current condition, this mode finishes. The duration of this mode is determined by the PWM controller.

One switching cycle of ZPM is completed at the end of this mode and the next switching cycle starts by turning on Q1 and Q2. The operational waveforms during one switching cycle are shown in Fig. 4.

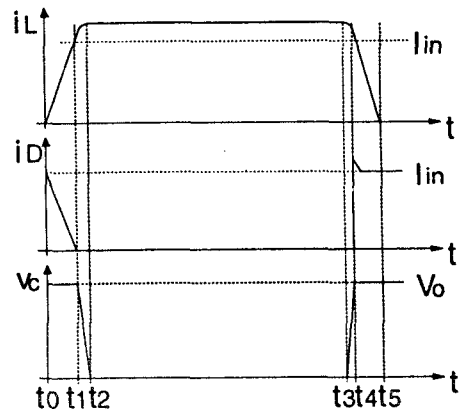

Fig.4 Circuit waveforms

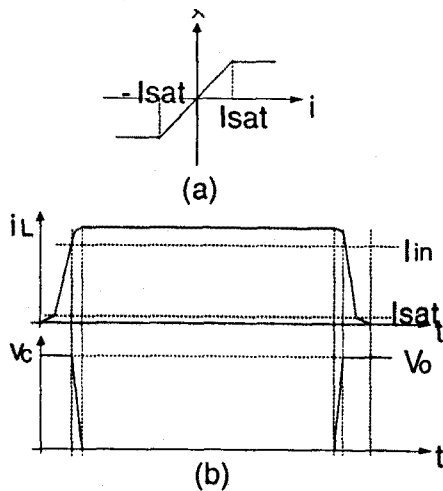

Fig.5 The effect of saturable reactor (a) λ - i characteristic curve of L_s , (b) i_L and v_c waveforms

IV. THE EFFECT OF SATURABLE INDUCTOR

As explained in the previous chapter, the diodes in ZPM are turned off at zero current condition, which produces current oscillation due to reverse recovery. By this oscillation, the soft switching of the switches will not be guaranteed and the voltage conversion ratio is affected adversely.

A saturable inductor L_s in series with the commutation inductor L_r , can remove the oscillation. Fig. 5 shows the inductor current and capacitor voltage waveforms. When i_L becomes higher than I_{sat} , L_s is saturated and L_r appears only as in the steady state analysis. Below I_{sat} , L_s has high inductance and the slope of i_L is alleviated. L_s lessens the peak reverse current of the diodes and, thus, significantly reduces the oscillation. The commutation time is increased slightly by adding the saturable inductor. The ZVS PWM converters using ZPM with saturable inductor are presented in Fig. 6.

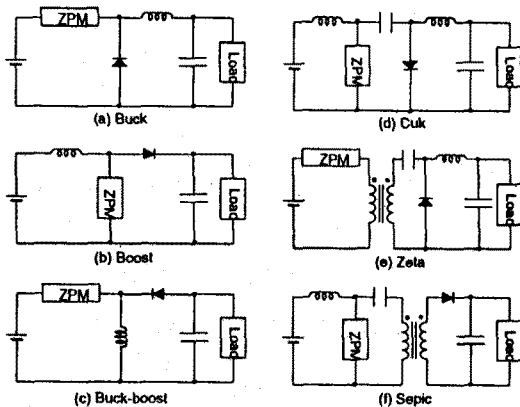

Fig. 6 ZVS PWM converter family

V. EXPERIMENTS AND DISCUSSIONS

Experimental waveforms for the boost ZVS PWM converter without inserting L_s are presented in Fig. 7. The current oscillation appears significantly. The oscillation frequency is determined by the resonance of the commutation inductor L_r and the diode junction capacitors and the magnitude increases proportionally to V_o . The capacitor voltage v_c also oscillates, which degrades the voltage conversion ratio that becomes serious at low input current. The experimental results inserting L_s are shown in Fig. 8. Below the saturation current of the saturable inductor, di/dt of the inductor current i_L becomes small owing to high inductance. There exists some difference between the two saturation points on the rising and the falling slopes due to the hysteresis characteristic of the saturable inductor.

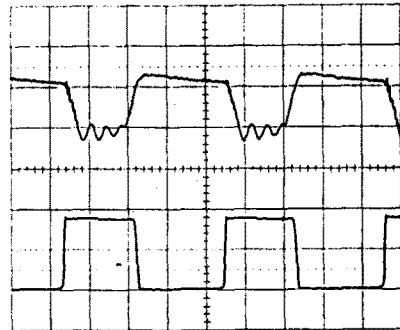

Fig.7 Experimental waveforms of the boost ZVS PWM converter without inserting L_s
upper trace : i_L (5A/div)
lower trace : v_c (50V/div)
time scale : 1 μ sec/div

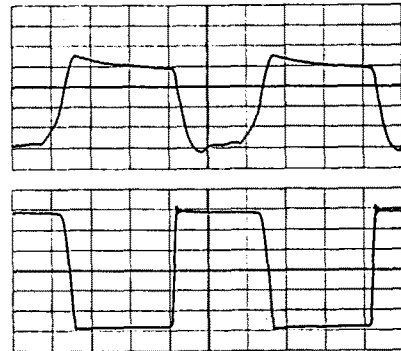
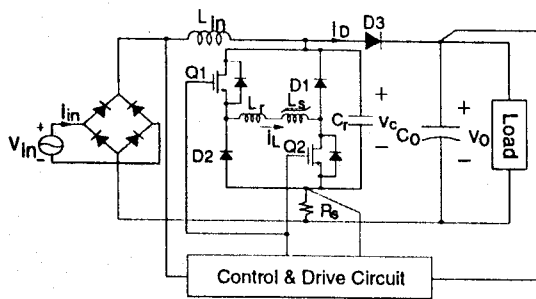

Fig. 8 Experimental waveforms of the ZVS PWM converter inserting L_s
upper trace : i_L (2A/div)
lower trace : v_c (20V/div)
time scale : 2 μ sec/div

The complete power circuit of the high power factor preregulator using ZVS PWM module with saturable inductor and the circuit parameters are shown in Fig. 9. Its output is controlled by current mode controller with constant switching frequency (100kHz). Experimental input voltage and current waveforms are shown in Fig. 10. due to the low resolution of the digital storage oscilloscope, the input current ripple is not shown clearly.



Q1,Q2	IRF740 (International Rectifier)
D1,	D10LC40
L_{in}	350 μ H
L_r	30 μ H
L_s	110 μ H, $I_{sat}=0.4$ A
C_r	4700 pF
C_o	470 μ F
R_s	0.1 Ω /5W (for current sense)

Fig.9 Power factor correction circuit using the boost ZVS PWM converter

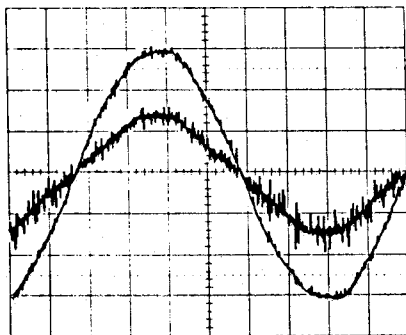

Fig.10 Experimental waveforms of the power factor correction circuit
 outer trace : V_{in} (100V/div)
 inner trace : i_{in} (5A/div)
 time scale : 2 msec/div

VI. CONCLUSION

The proposed ZVS PWM module shows the feature of constant frequency PWM with soft switching. The voltage stresses of all the semiconductor devices are equal to those of the conventional PWM converters. In addition it operates on a continuous conduction mode like the conventional PWM converter does. Thus ZPM can be substituted directly for the switches of the conventional PWM converters without modifying any circuit configuration. The current rating of ZPM is slightly higher than that of the conventional PWM converter because of the circulating current for zero voltage switching. Parasitic oscillations due to diode reverse recovery are removed by adding a saturable inductor in series with the commutation inductor.

This module is applicable to high voltage/high power system with high switching frequency as to be verified by the experiment of 1KW power factor correction circuit.

REFERENCES

- [1] K.H. Liu, R. Oruganti and F.C. Lee, "Resonant Switches - Topologies And Characteristic", IEEE PESC Rec., pp. 106-116, 1985
- [2] K. Harada and H. Sakamoto, "On The Saturable Inductor Commutation For Zero-Voltage Switching", IEEE PESC Rec., pp. 189-196, 1990
- [3] F.C. Schwarz, "A Method of Resonant Current Pulse Modulation For Power Converters", IEEE Transactions on IECI Vol. 17, No. 3, pp. 209-221, May, 1971
- [4] W.A. Tabisz and F.C. Lee, "Zero-Voltage-Switching Multi-Resonant Technique - A Novel Approach to Improve Performance of High-Frequency Quasi-Resonant Converters", IEEE PESC Rec., pp. 9-17, 1988
- [5] J.P. Agrawal and C.O. Lee, "Determination of Cross Regulation in Multioutput Resonant Converters", IEEE APEC Proc., pp. 697-705, 1990
- [6] J. G. Cho, H. S. Kim and G. H. Cho, "Novel Soft Switching PWM Converter Using A New Parallel Resonant DC-Link", IEEE PESC Rec., pp. 241-247, 1991